

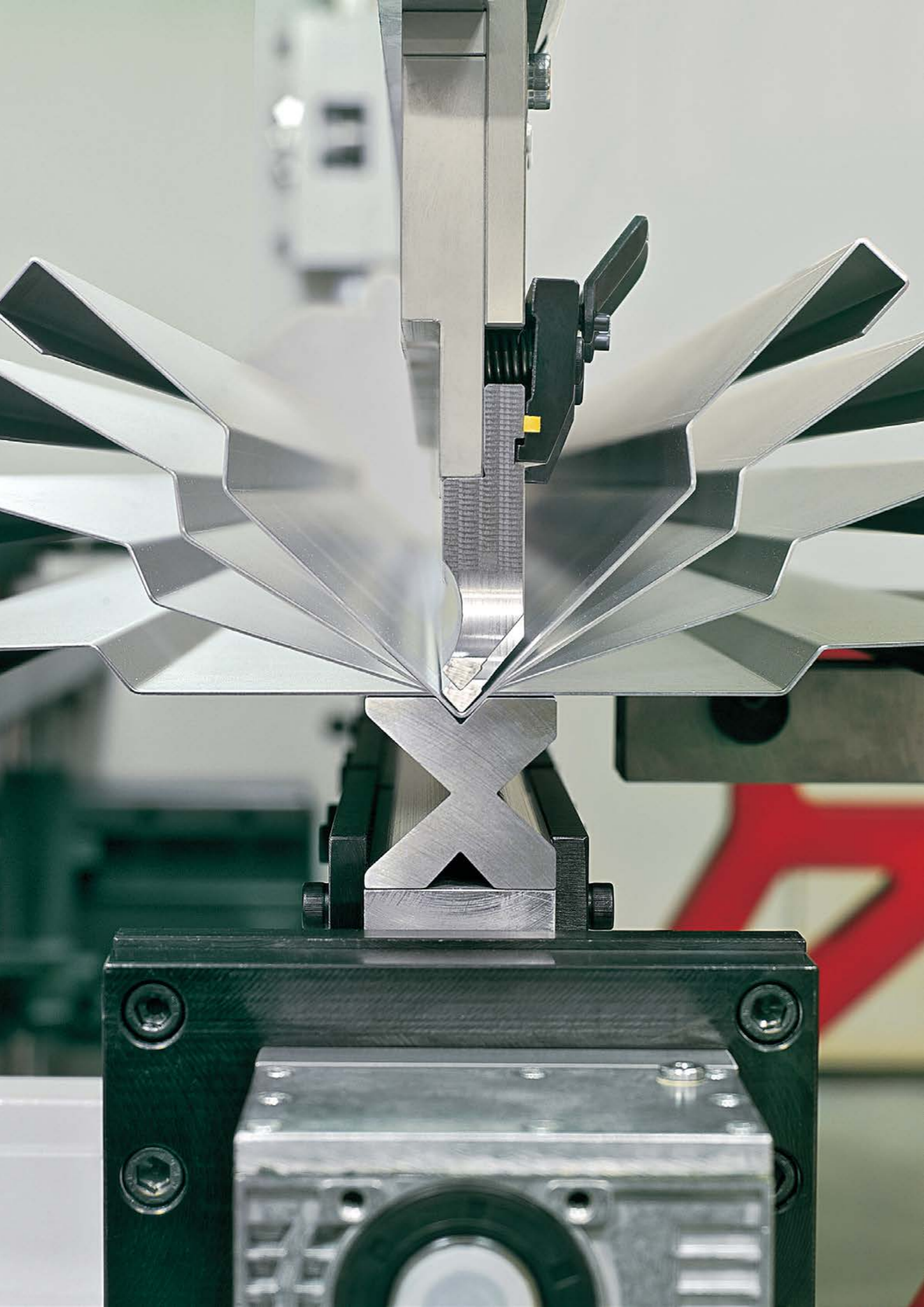

**EURO-SPEC
PRESS BRAKE
TOOLS**





PUNCHES	4
PUNCHES 90°	7
PUNCHES 88°	12
PUNCHES 85°	20
PUNCHES 60°	23
PUNCHES 45°	25
PUNCHES 35°	26
PUNCHES 30°	27
PUNCHES 26°	30
DIES 31	32
4V DIES	34
1V DIES	35
T DIES H80	41
T DIES H120	53
DIE INSERTS HOLDER	65
DIE INSERTS	66
FLATTENING HEMMING TOOLS	72
ACCESSORIES	76
RADIUS TOOLS HOLDERS	76
RADIUS TOOLS	77
NYLON INSERT AND HOLDERS	85
POLYURETHANE INSERTS AND HOLDERS	86
ADAPTORS TO FIT TOOLS SUITABLE FOR ANY TYPE OF PRESS BRAKE	87
TANGS ON REQUEST	88
ADAPTORS	89
ES CLAMP PN	92
ADJUSTABLE INTERMEDIATES	93
FIXED INTERMEDIATES	93
CLAMPS	94
LOWER ADAPTORS	97
ACCESSORIES	99
MULTI V DIES ON REQUEST	100
SPECIAL TOOLS ON REQUEST	101
EXAMPLE SPECIAL TOOLS	102
MODIFICATION RADIUS CHART	103
BENDING / TONNAGE CHARTS	104
KNOWLEDGE BASE ARTICLES	106
MAINTENANCE	107

STANDARD SECTIONING

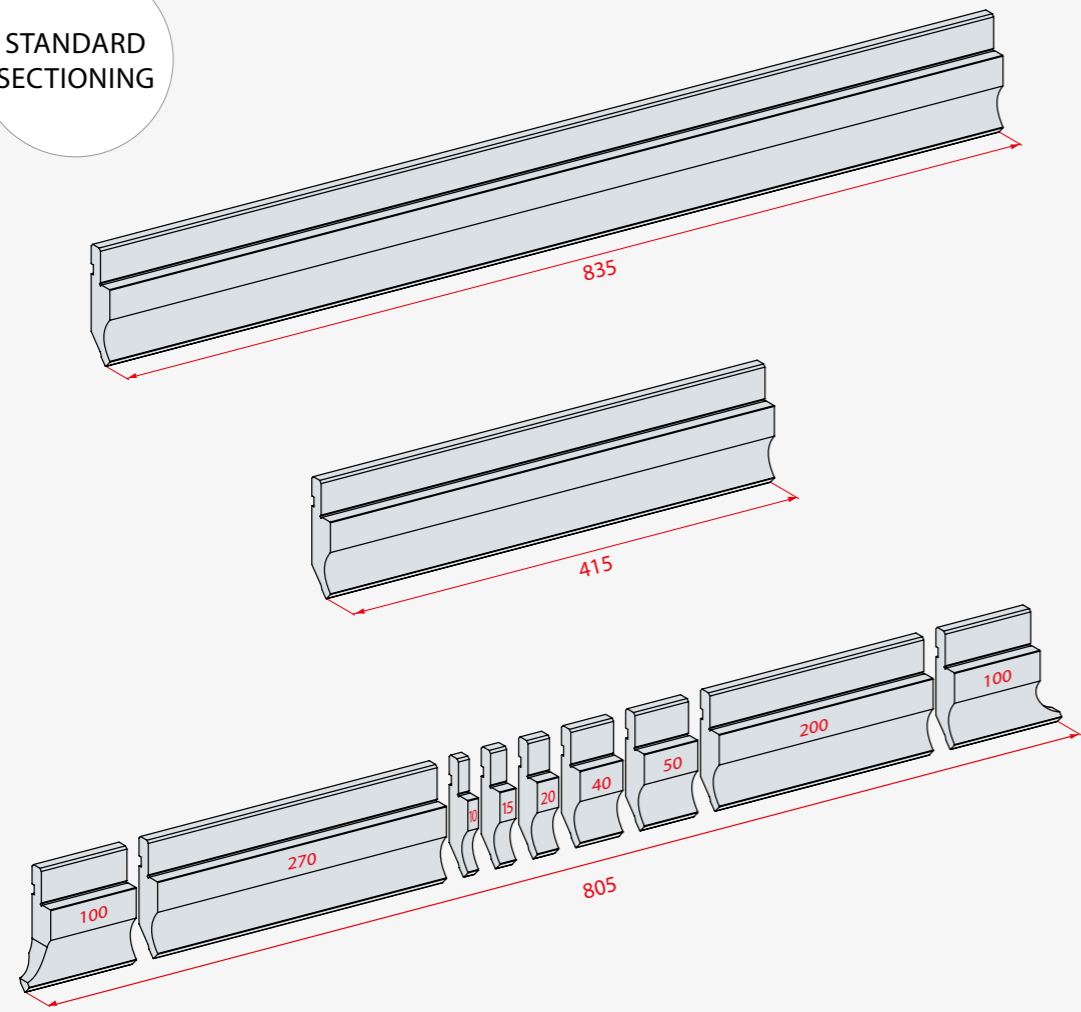

MILLED HORN

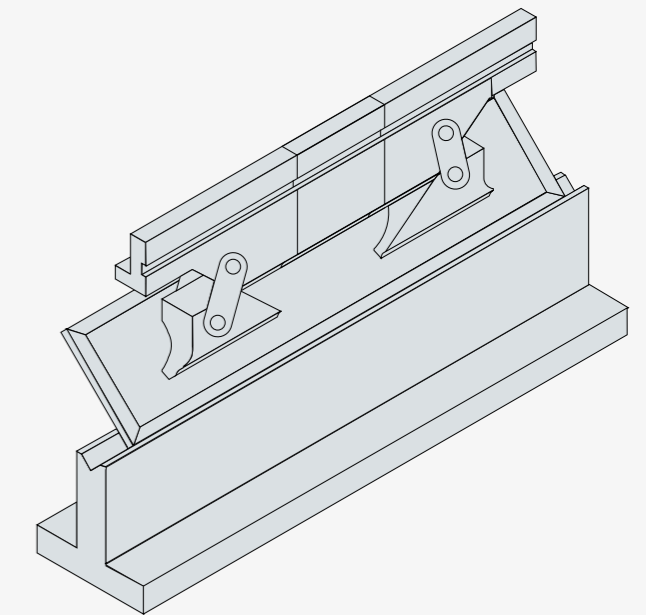
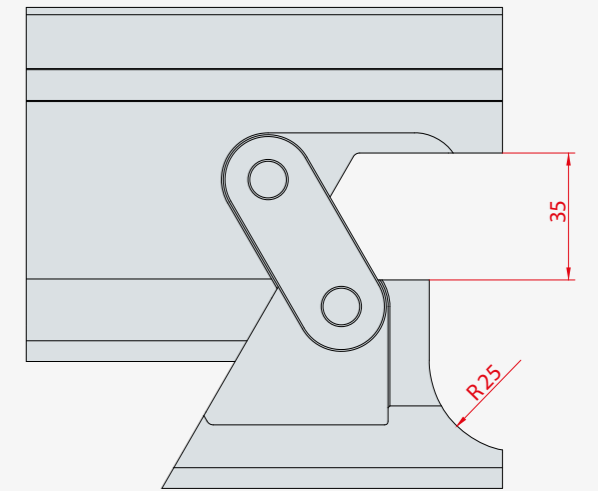
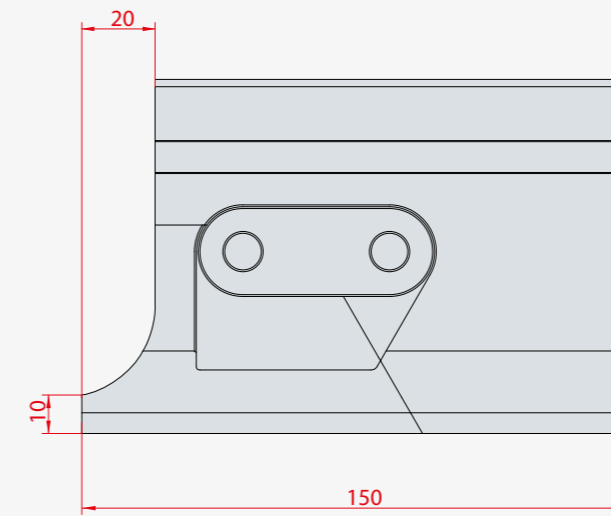
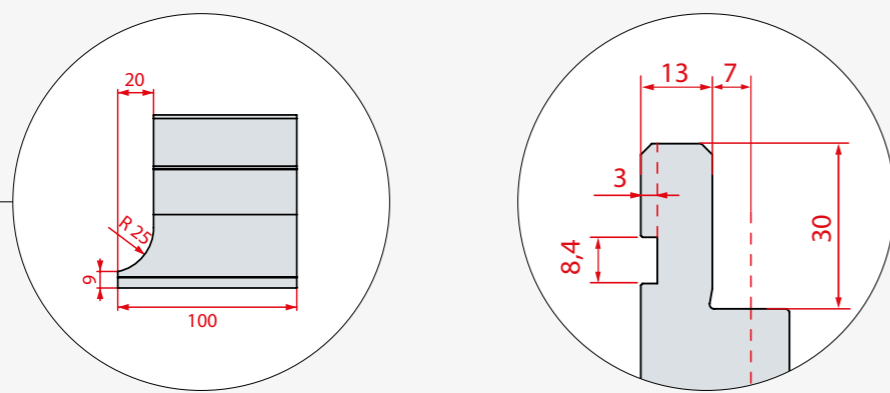

PUCH	MOVING HORNS
A1010	A1010S
A1011	A1011S
A1064	A1064S
A1065	A1065S
A1047	A1047S

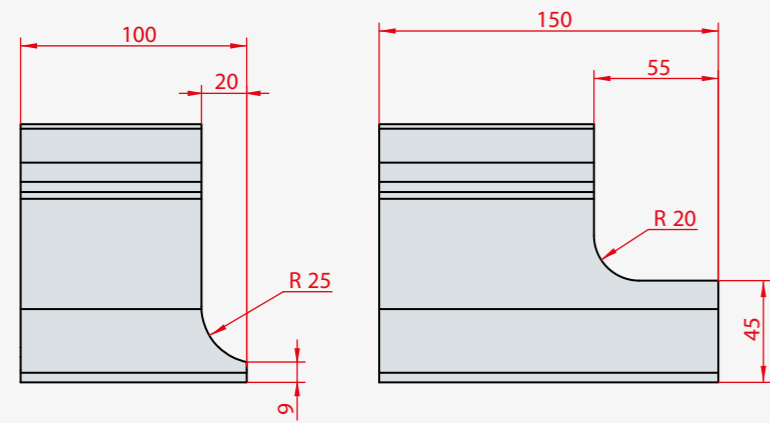

SPECIAL HORNS



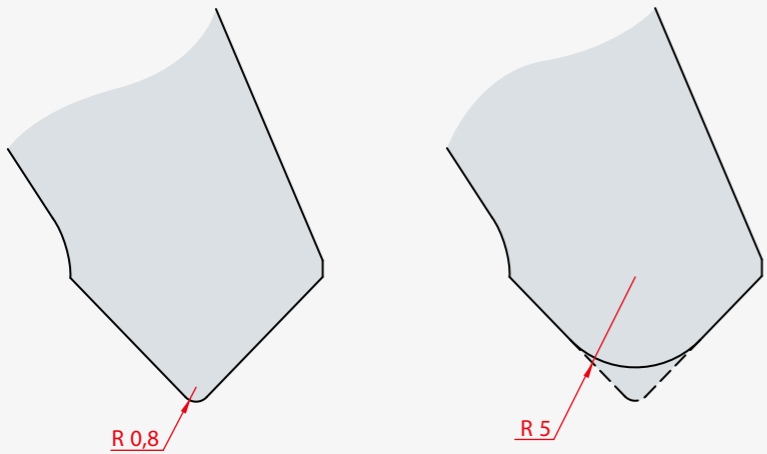

SPECIAL SEGMENTATION

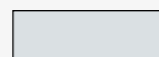

RADIUS MODIFICATION

MATERIAL TYPE :

-  Standard C45
-  C45 Quenched
-  42CrMo4 Quenched

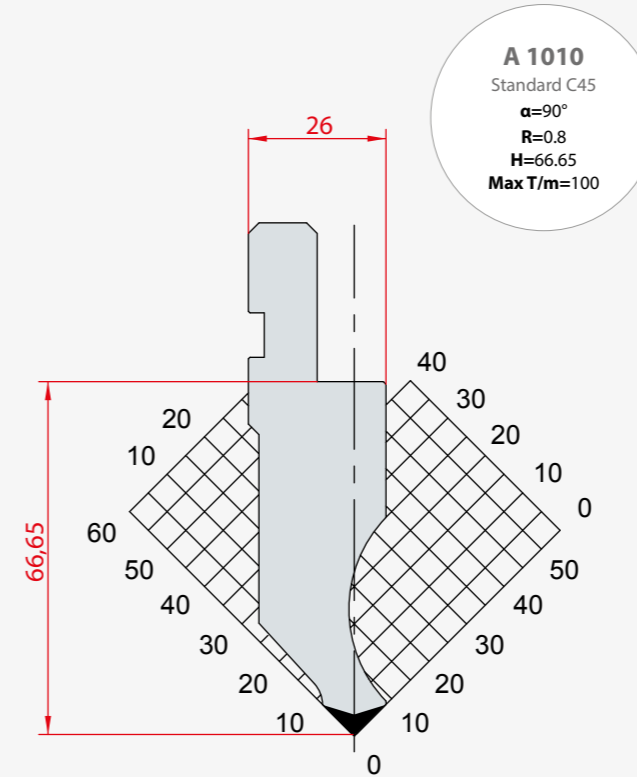

A 1010
Standard C45
 $\alpha=90^\circ$
R=0.8
H=66.65
Max T/m=100

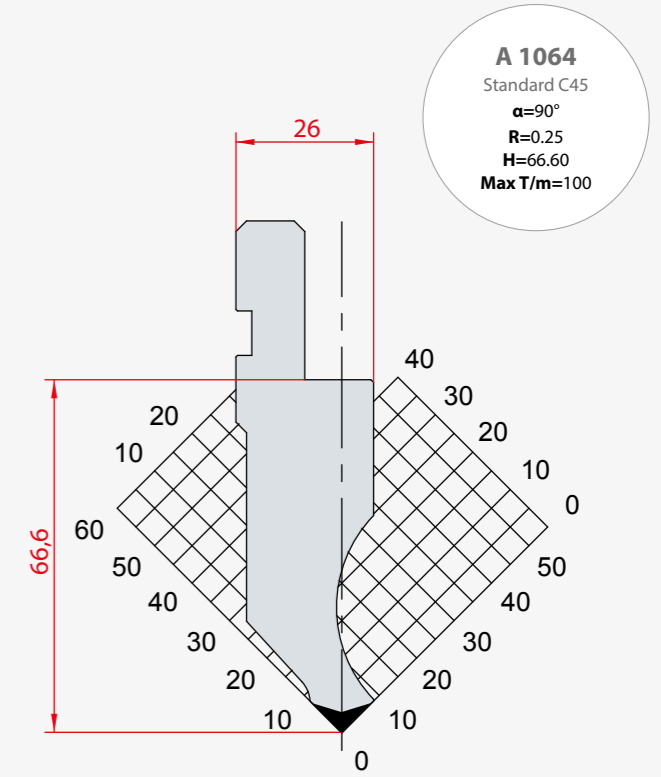

A 1064
Standard C45
 $\alpha=90^\circ$
R=0.25
H=66.60
Max T/m=100

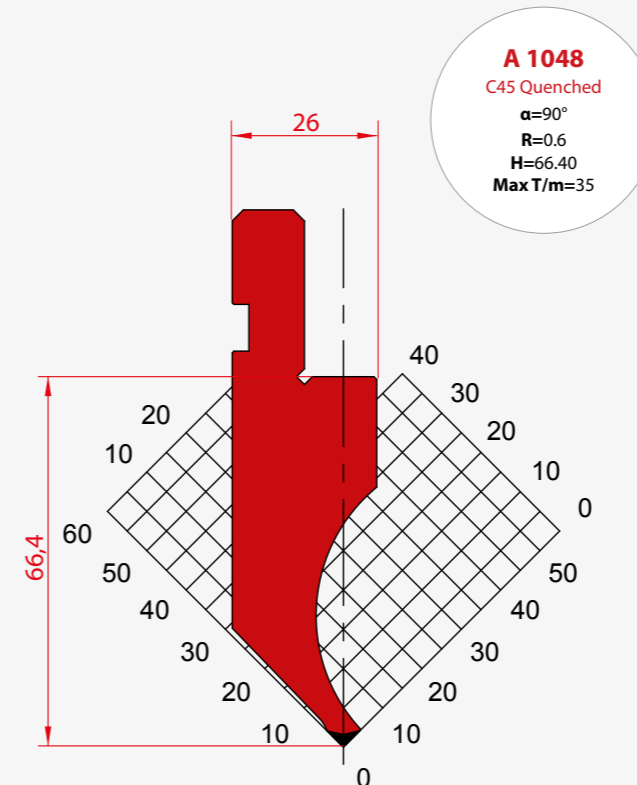

A 1048
C45 Quenched
 $\alpha=90^\circ$
R=0.6
H=66.40
Max T/m=35

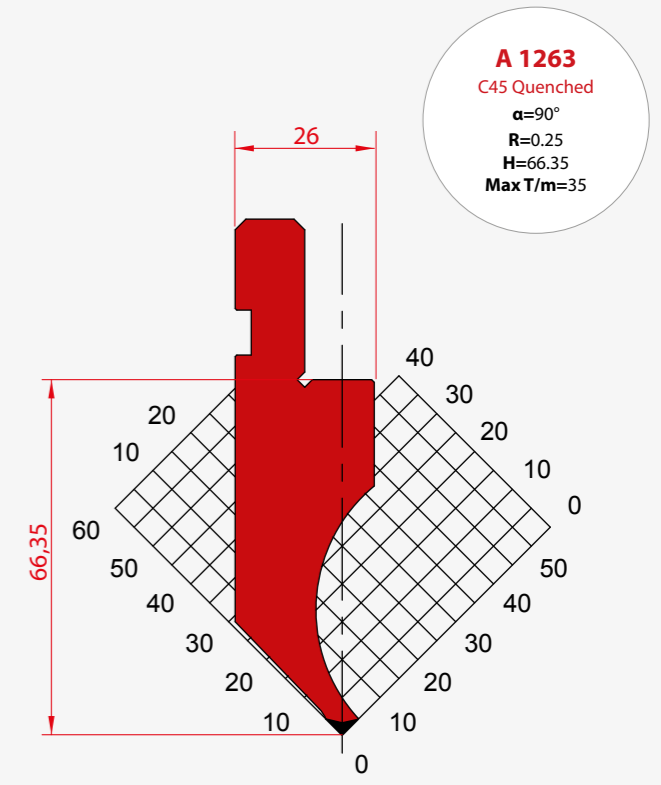

A 1263
C45 Quenched
 $\alpha=90^\circ$
R=0.25
H=66.35
Max T/m=35

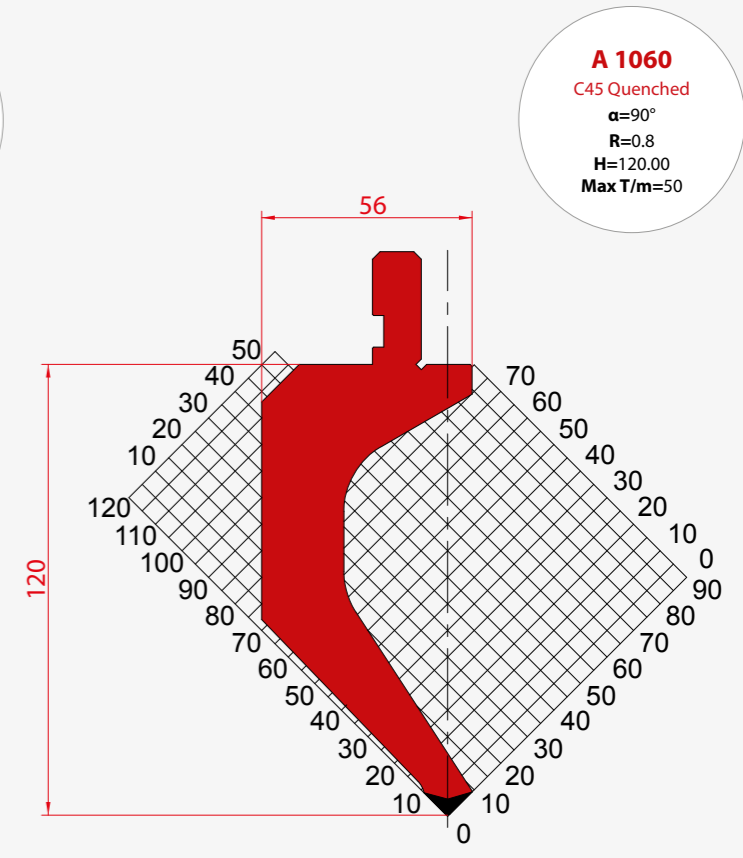
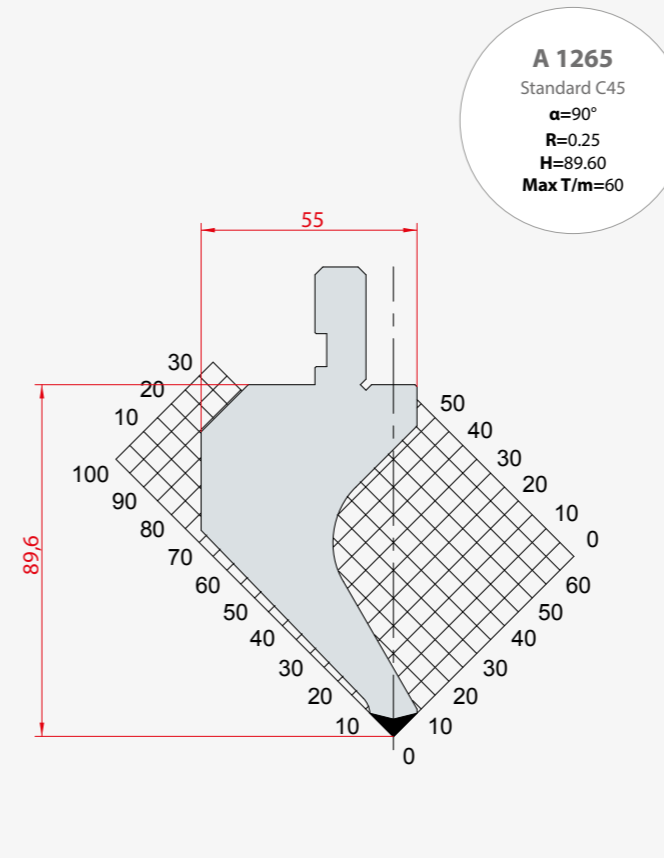
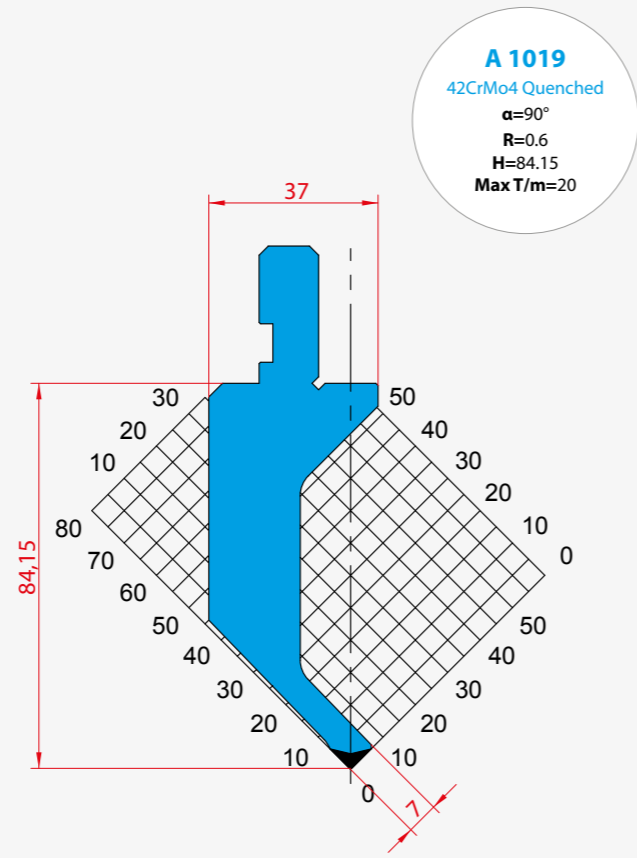
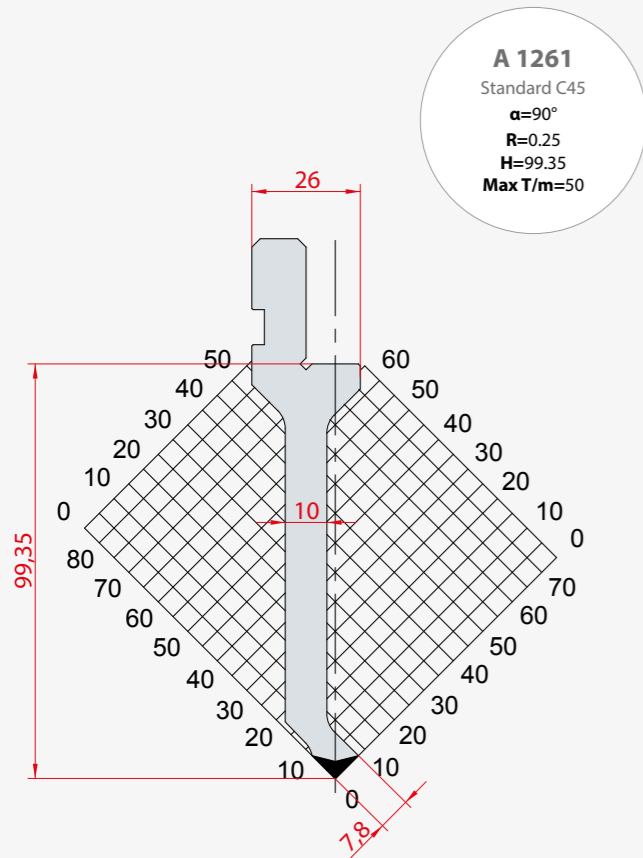
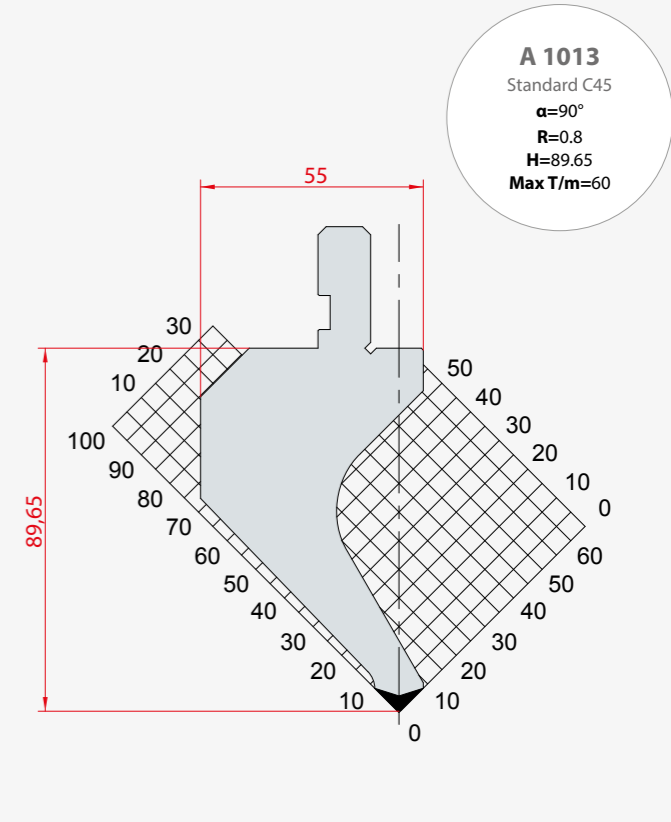
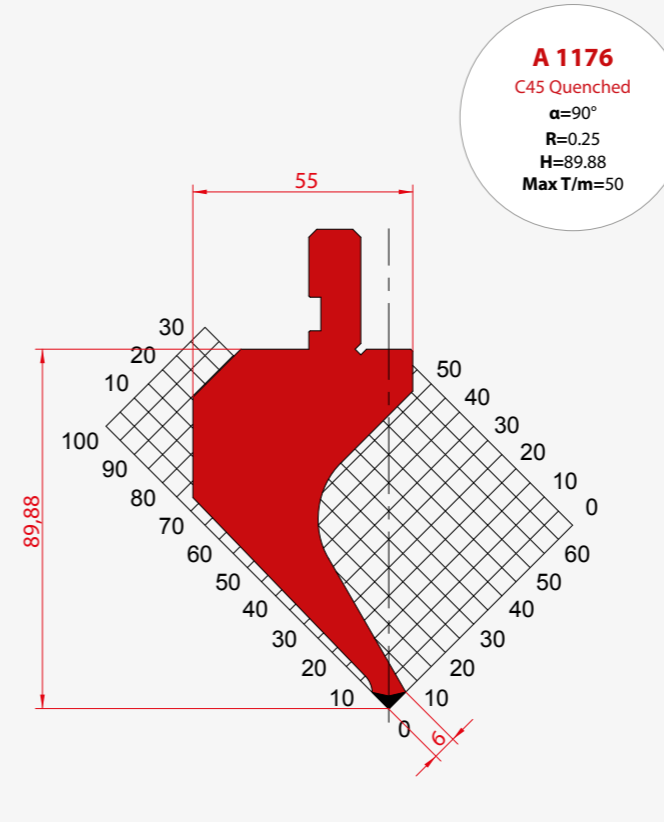
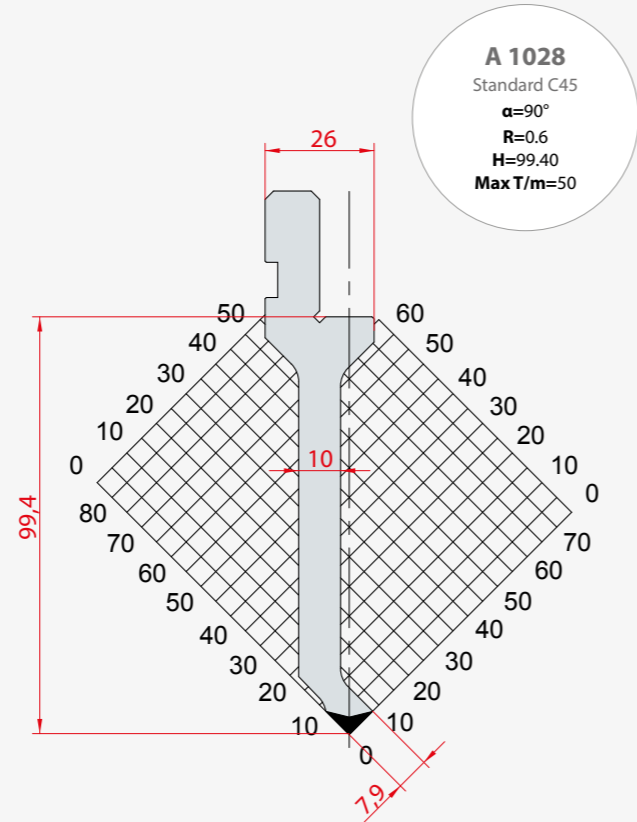
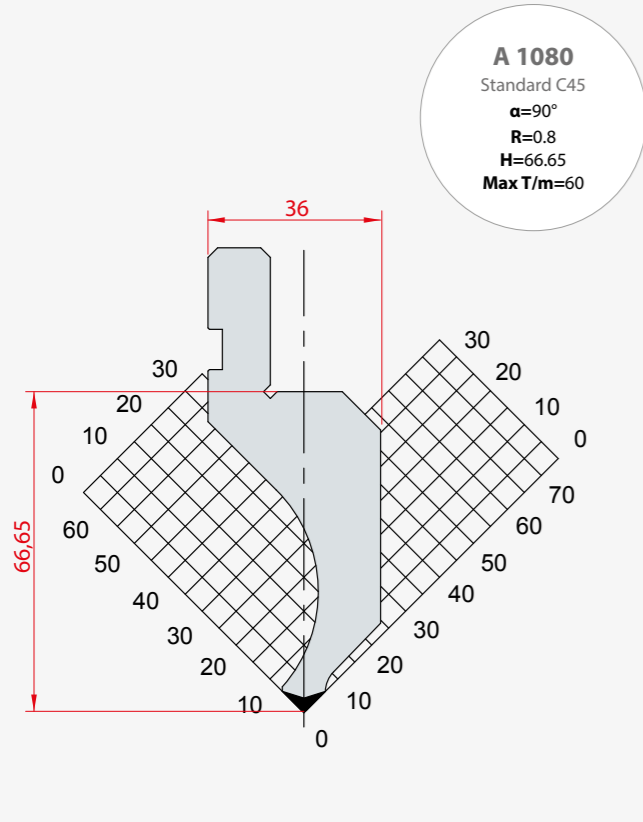

PUNCHES 90°

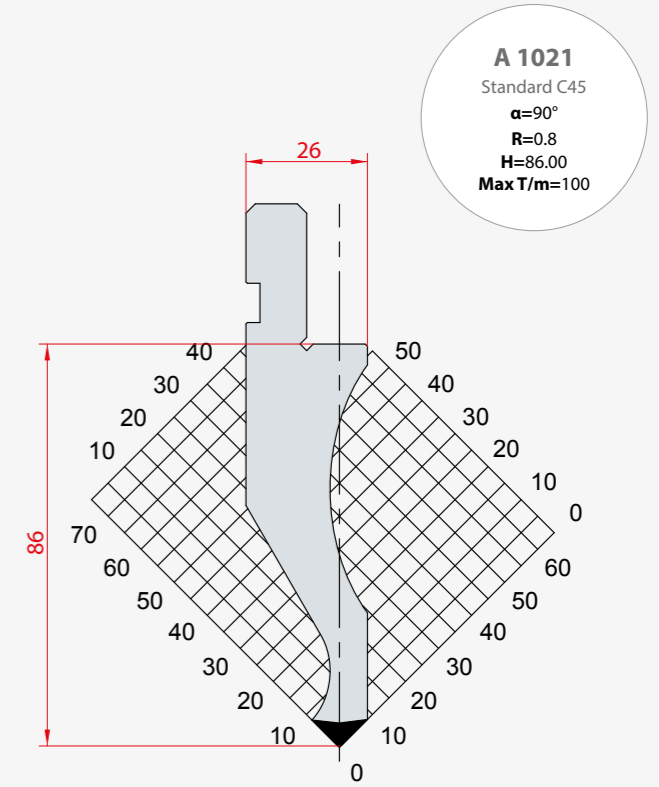
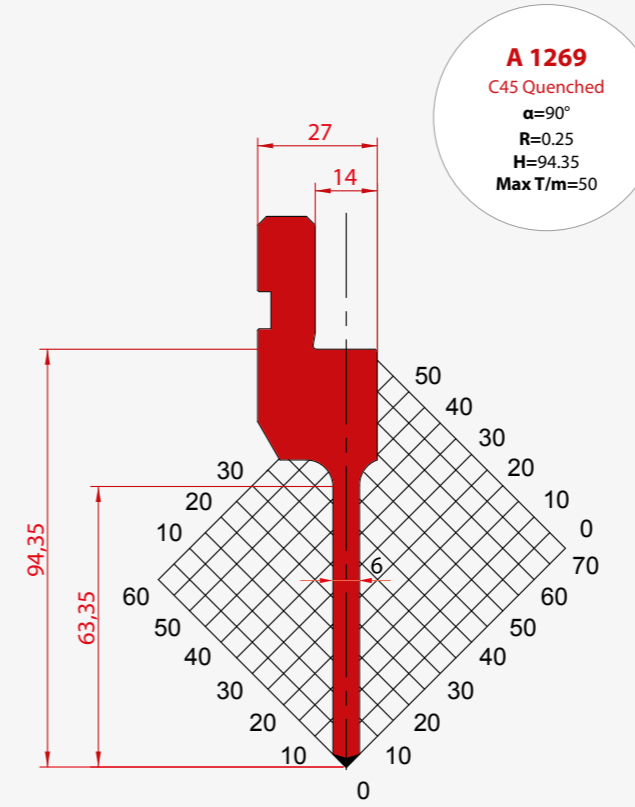
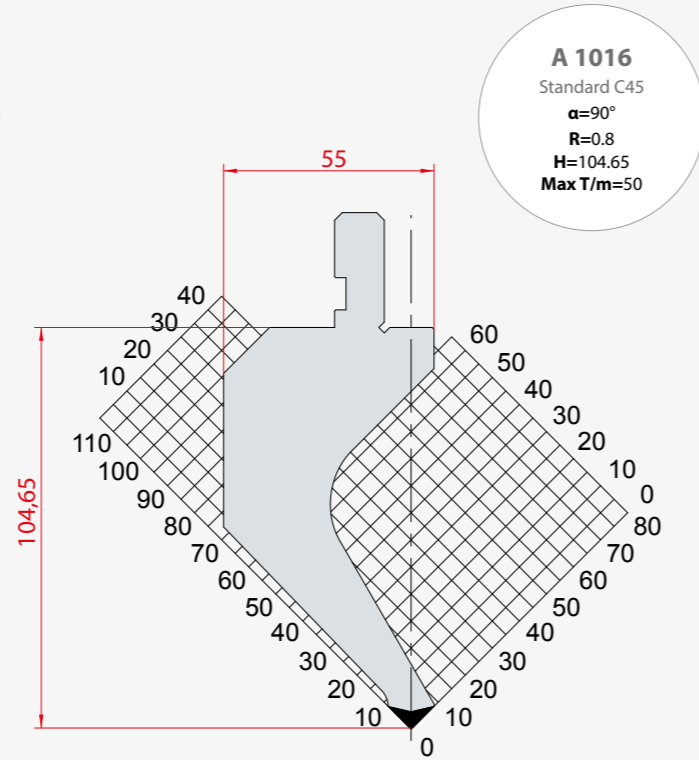
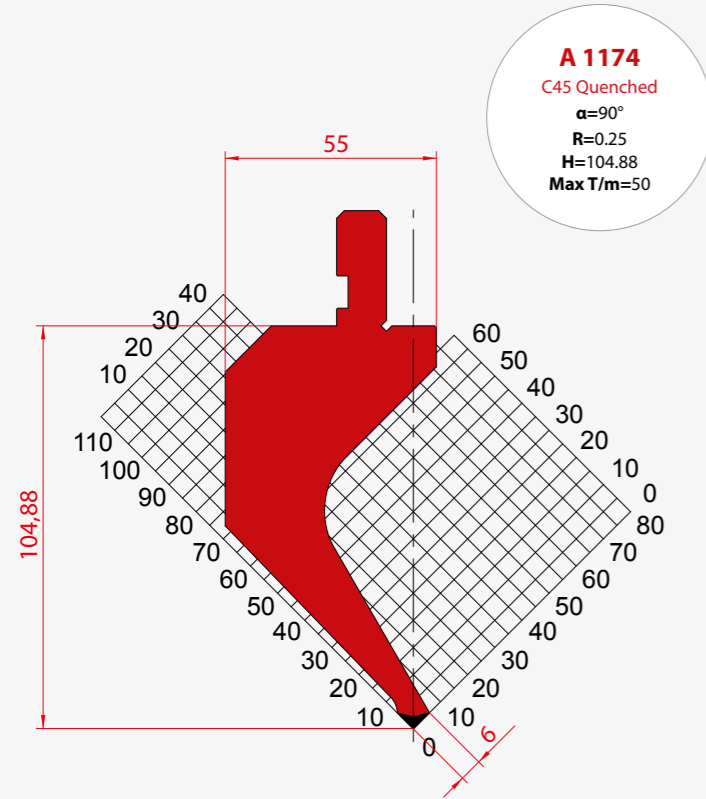

PUNCHES 88°

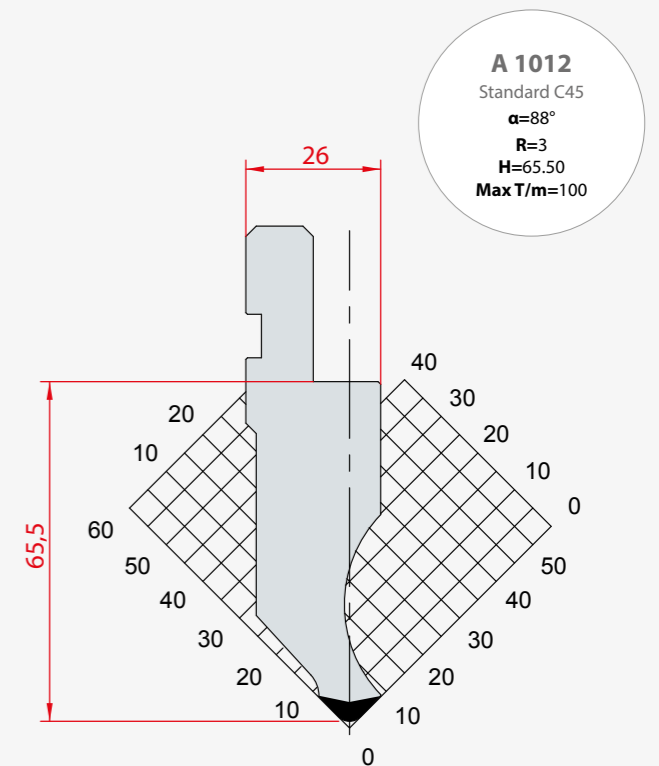
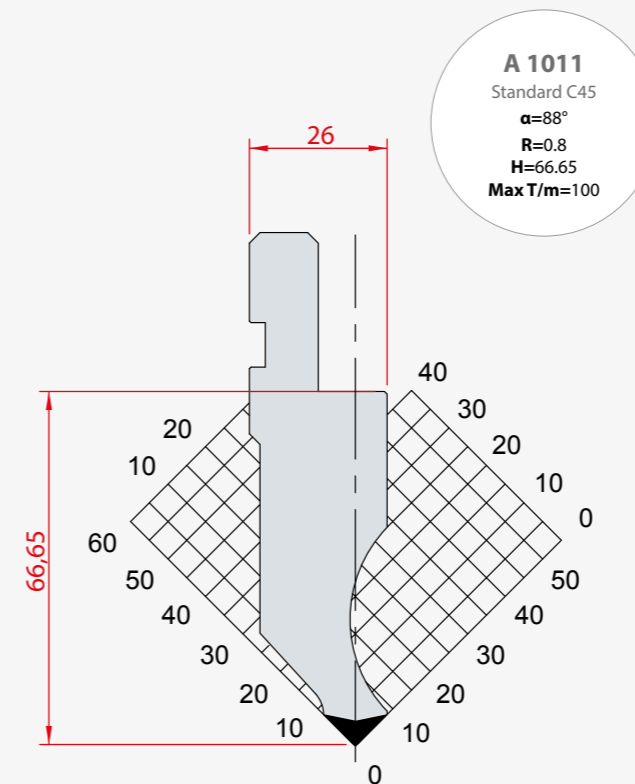
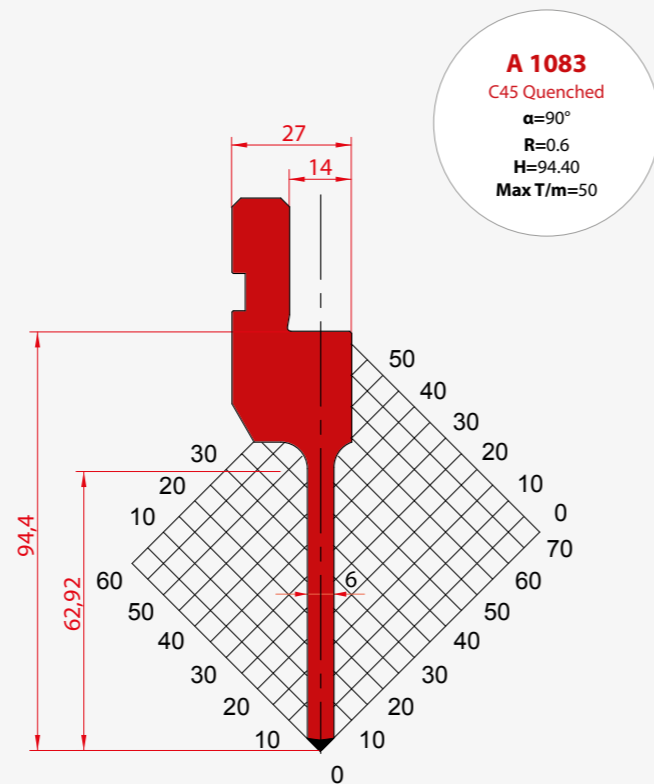
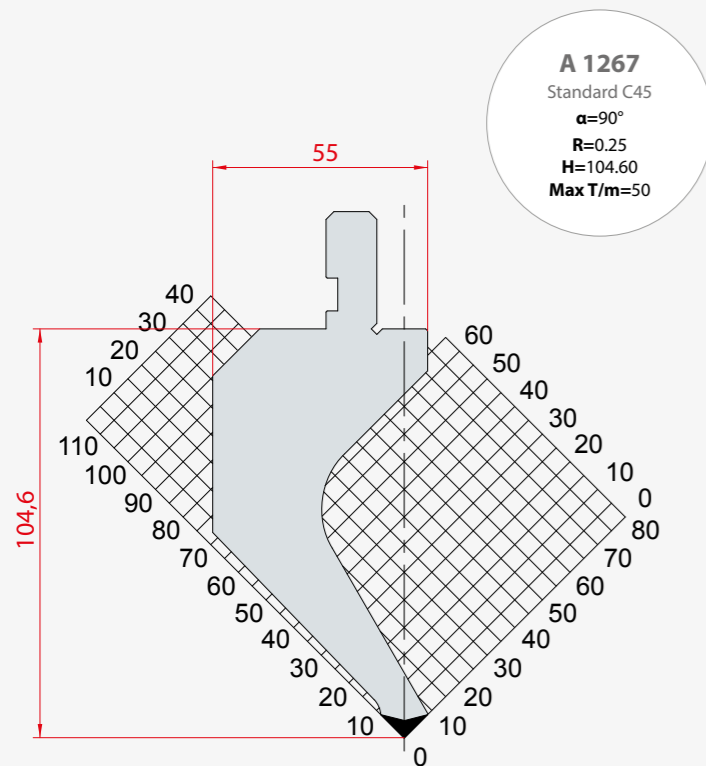

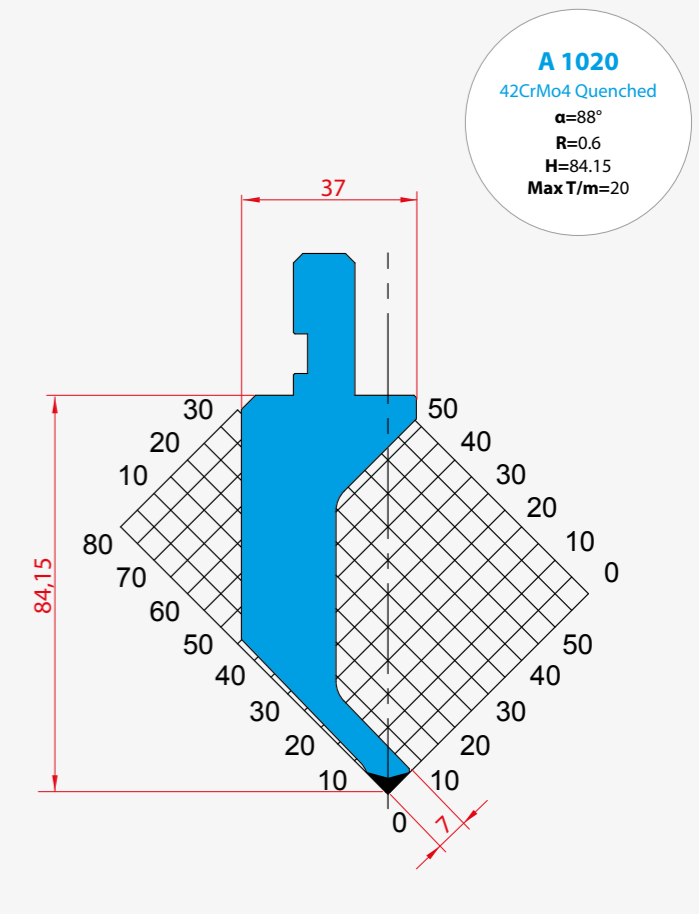
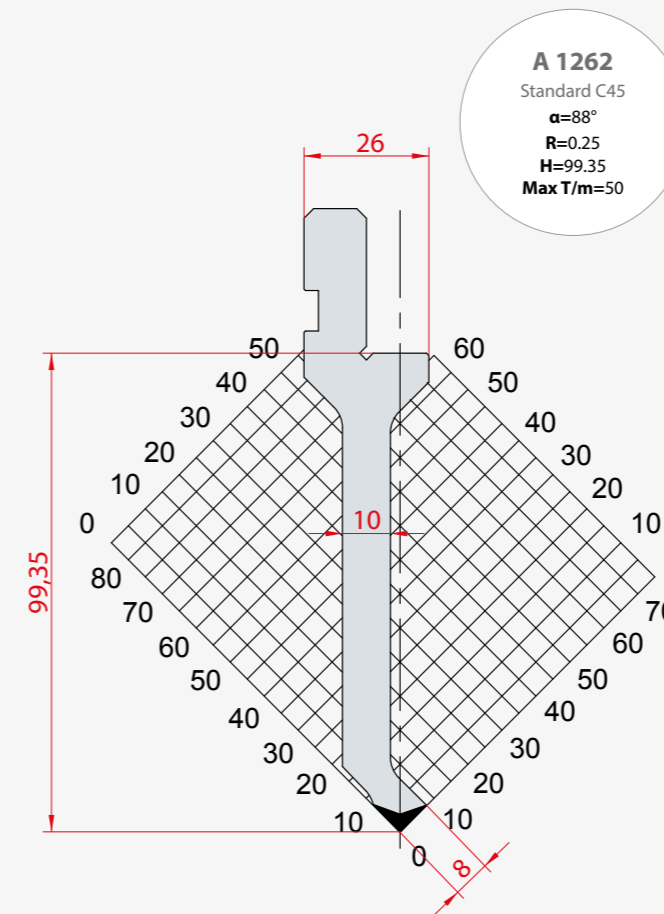
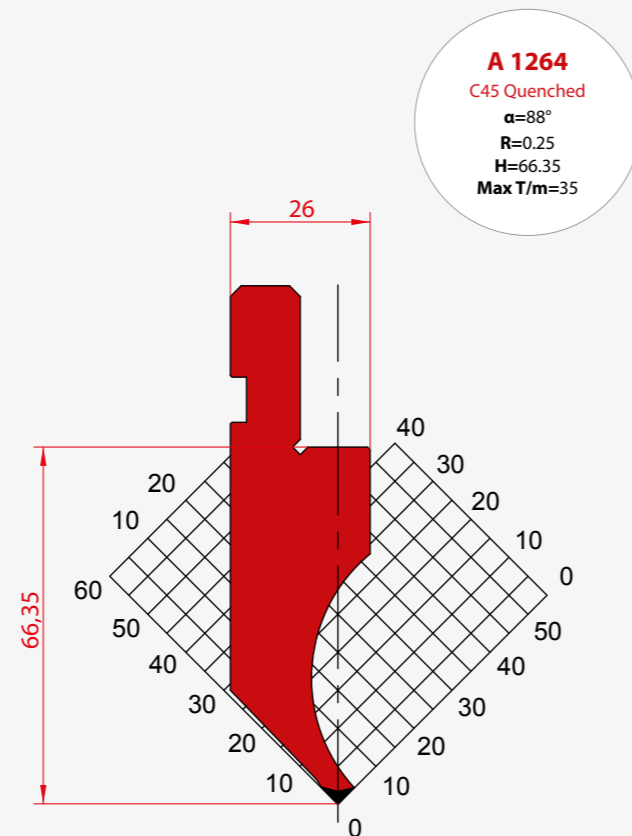
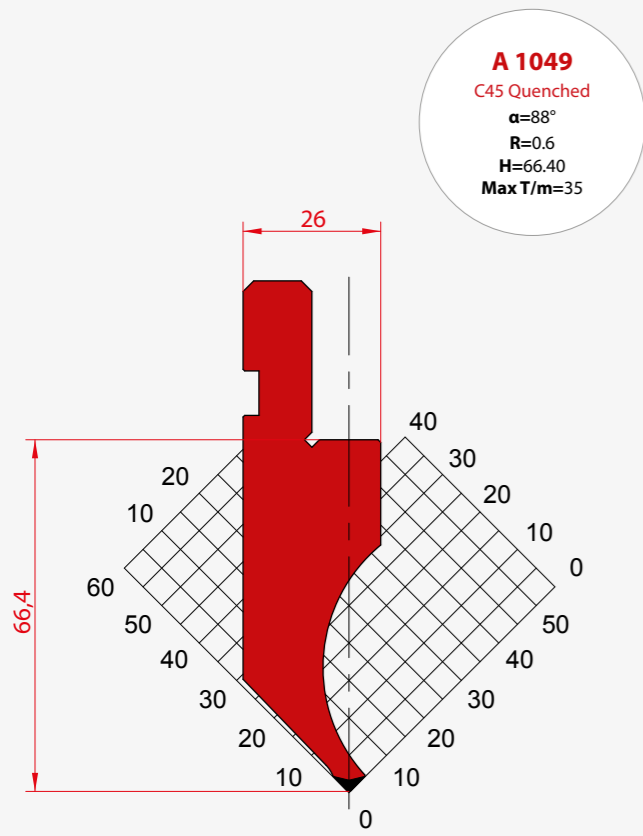
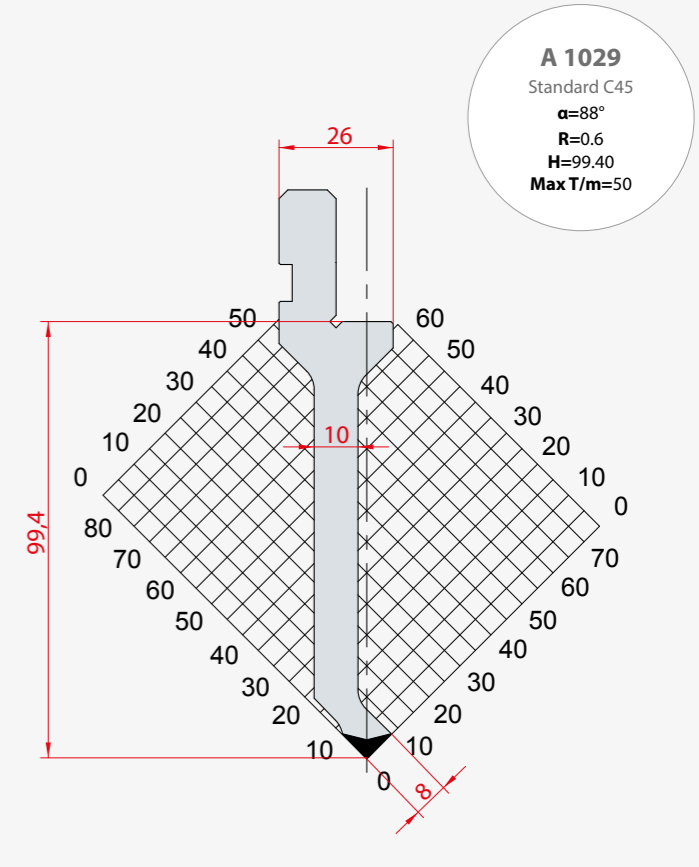
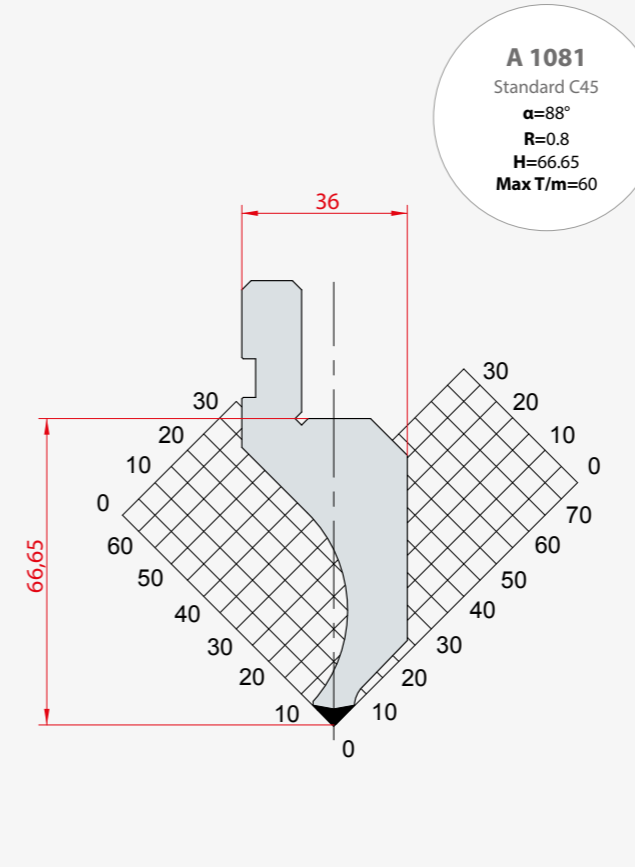
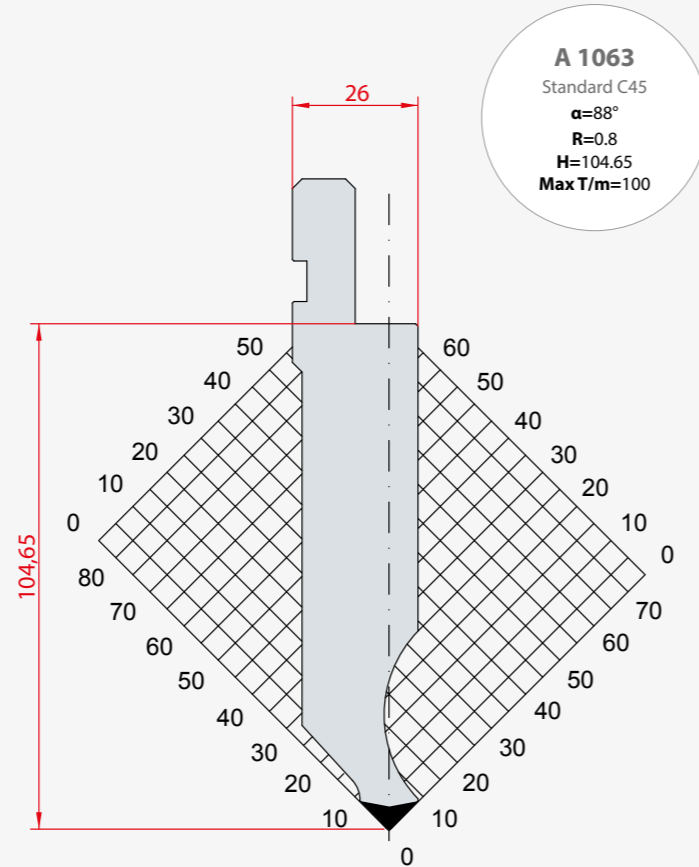
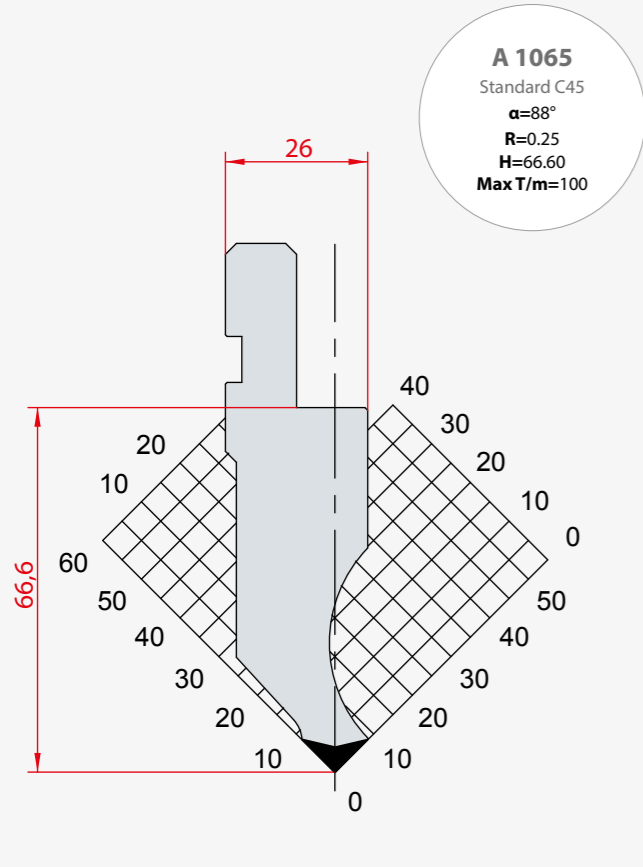

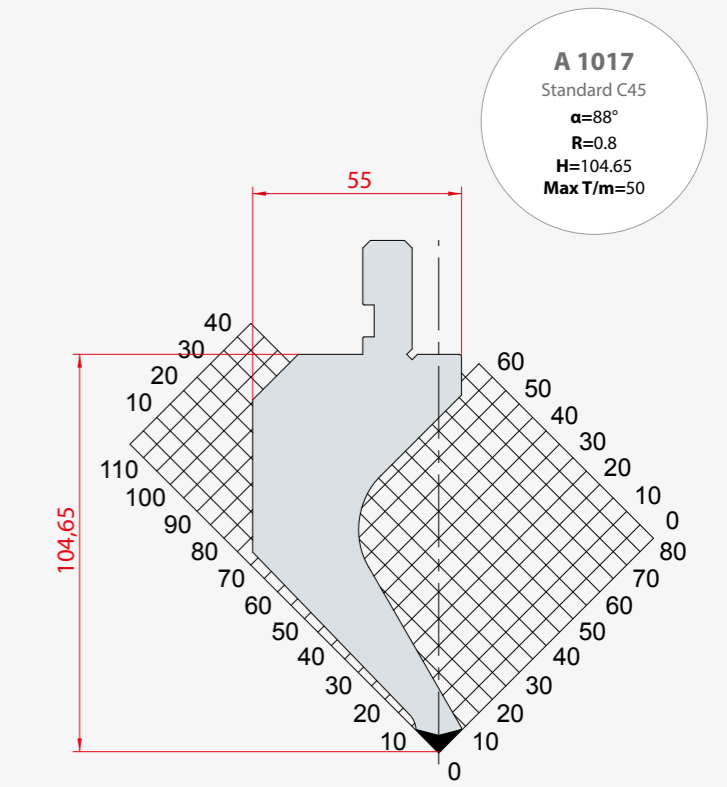
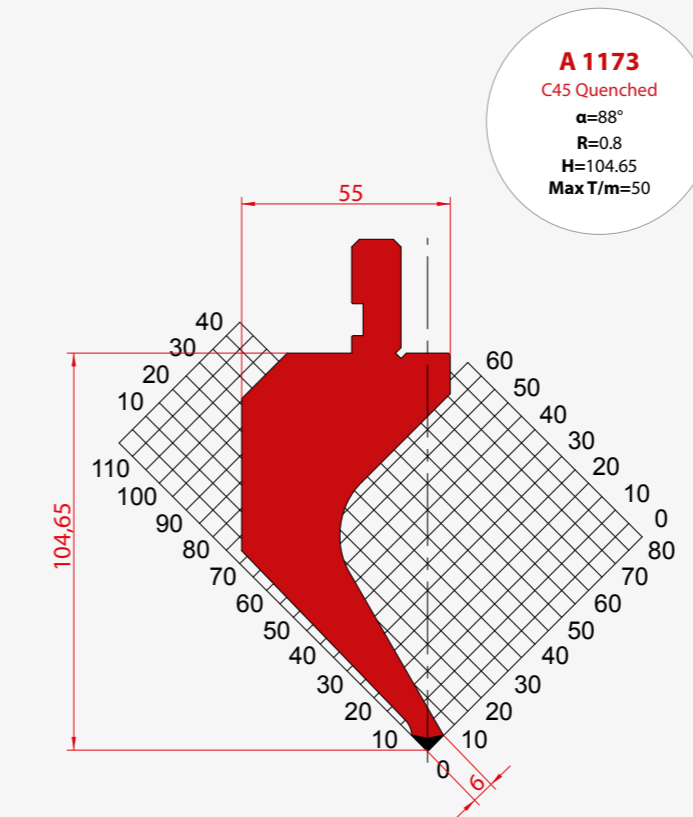
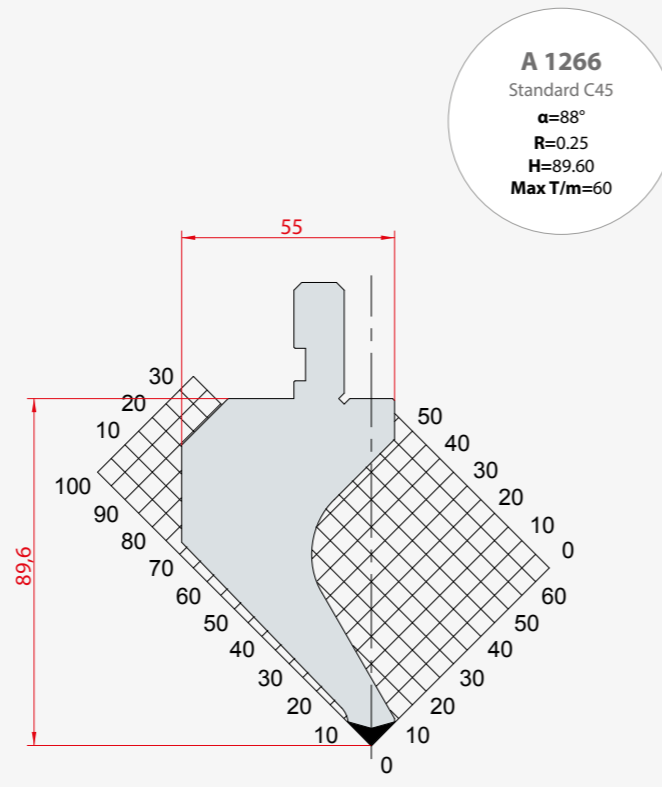
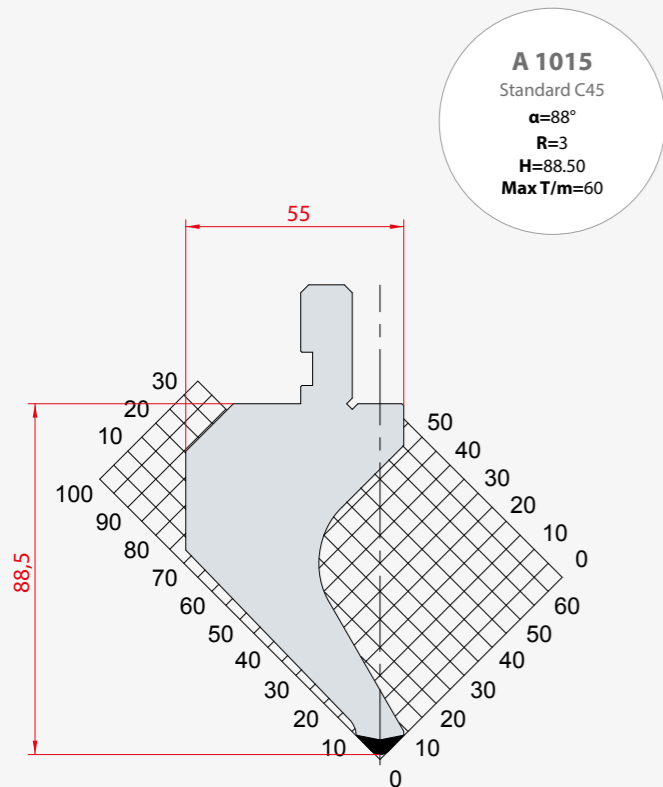
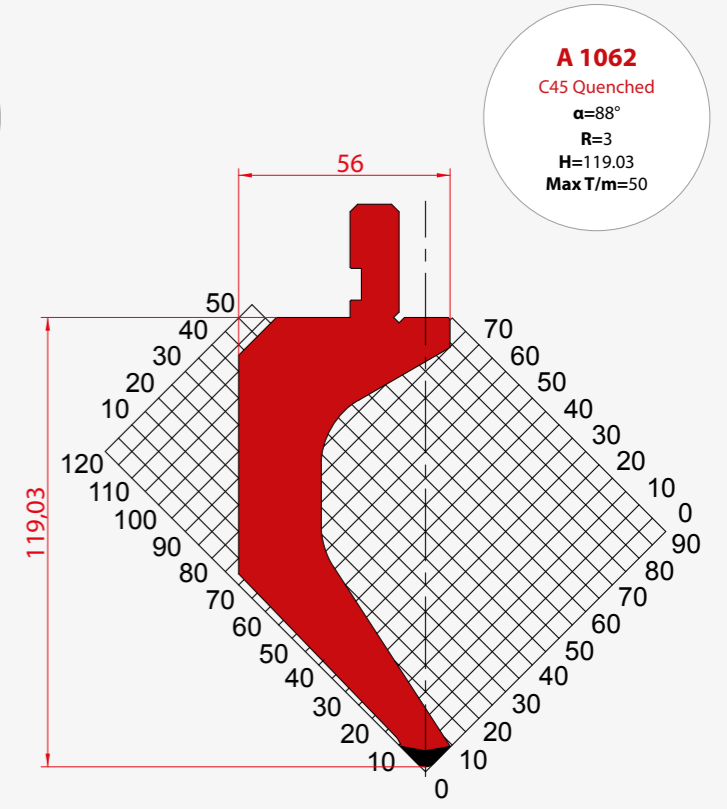
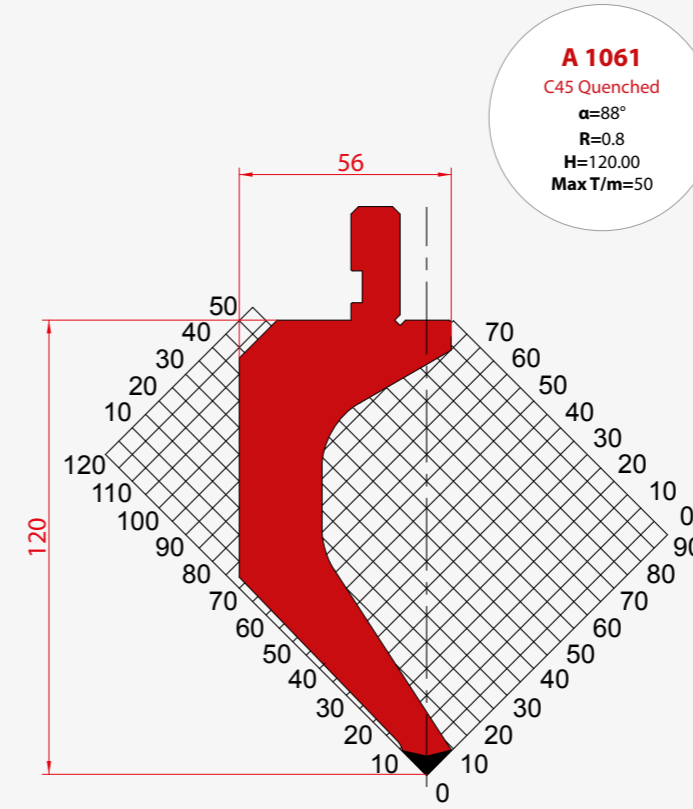
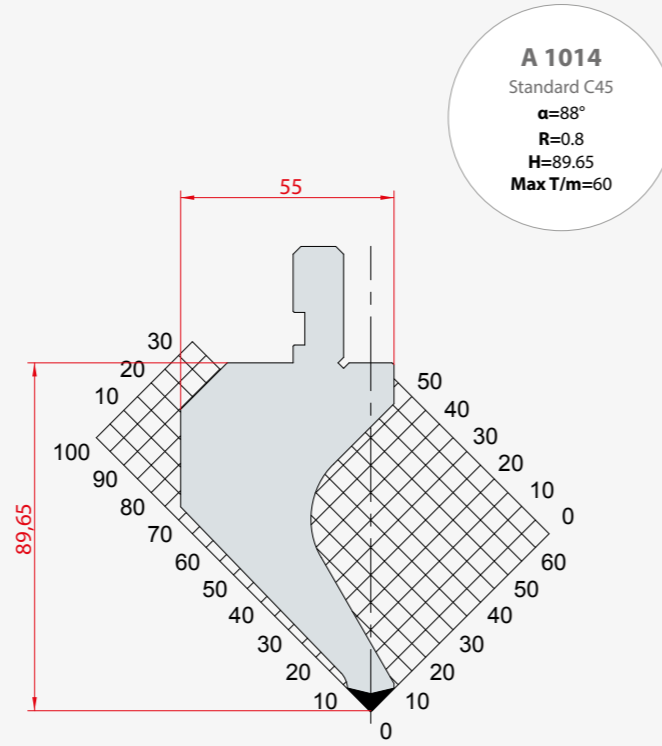
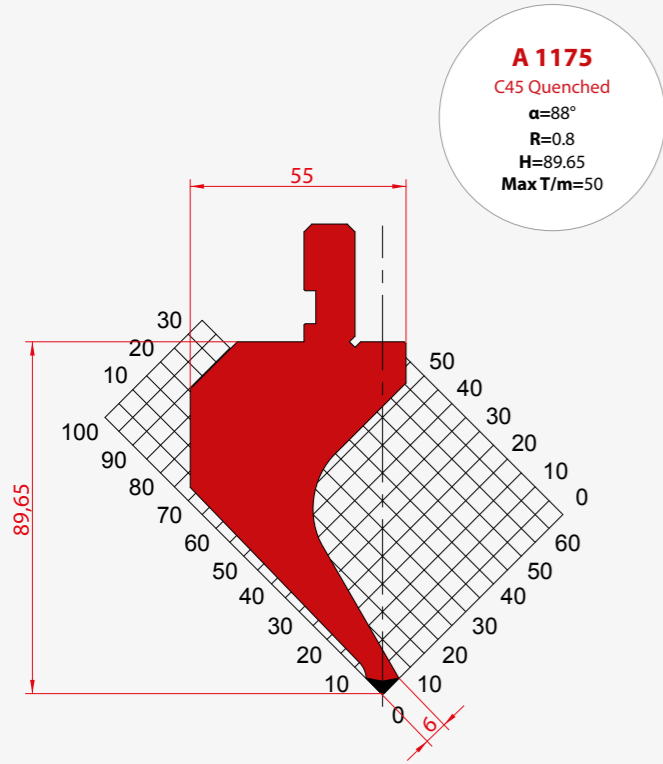

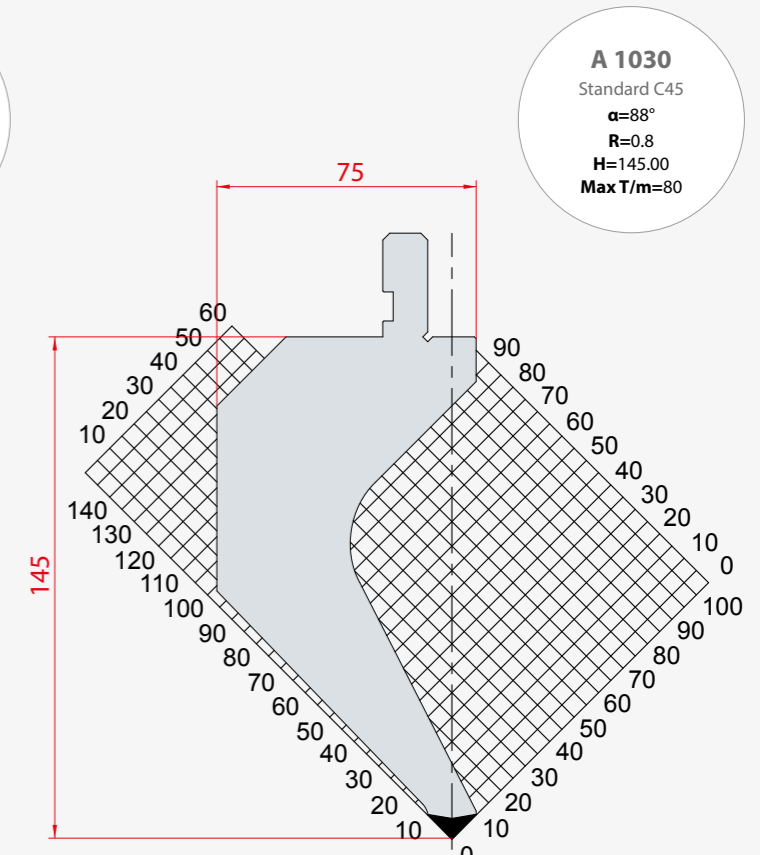
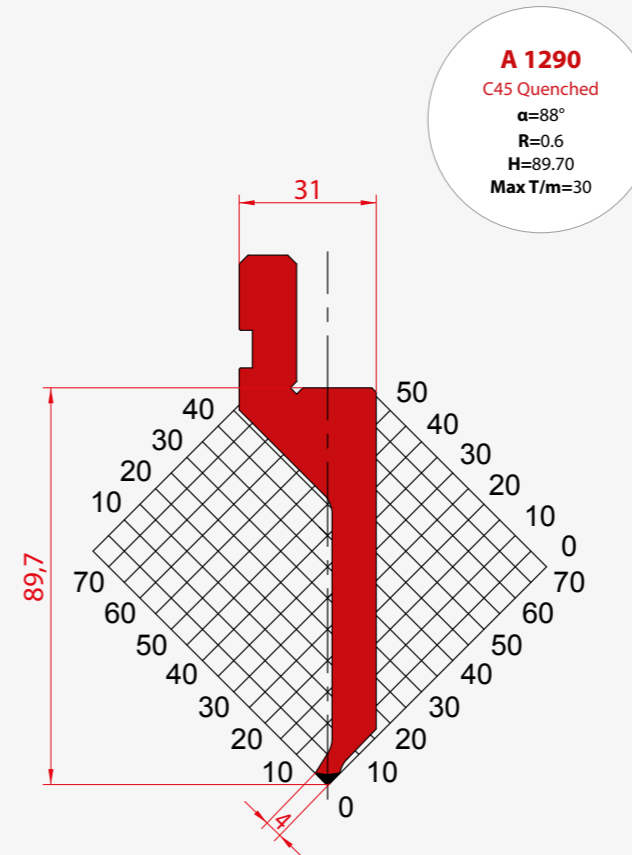
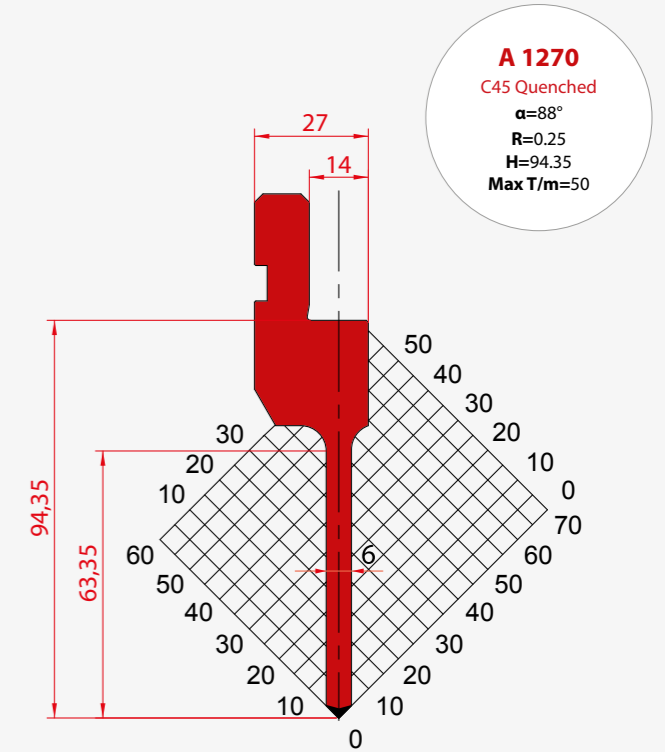
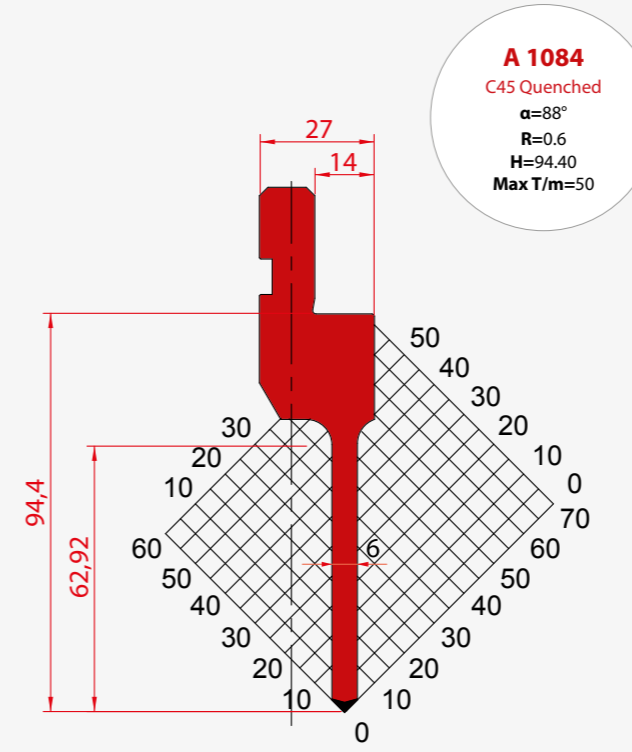
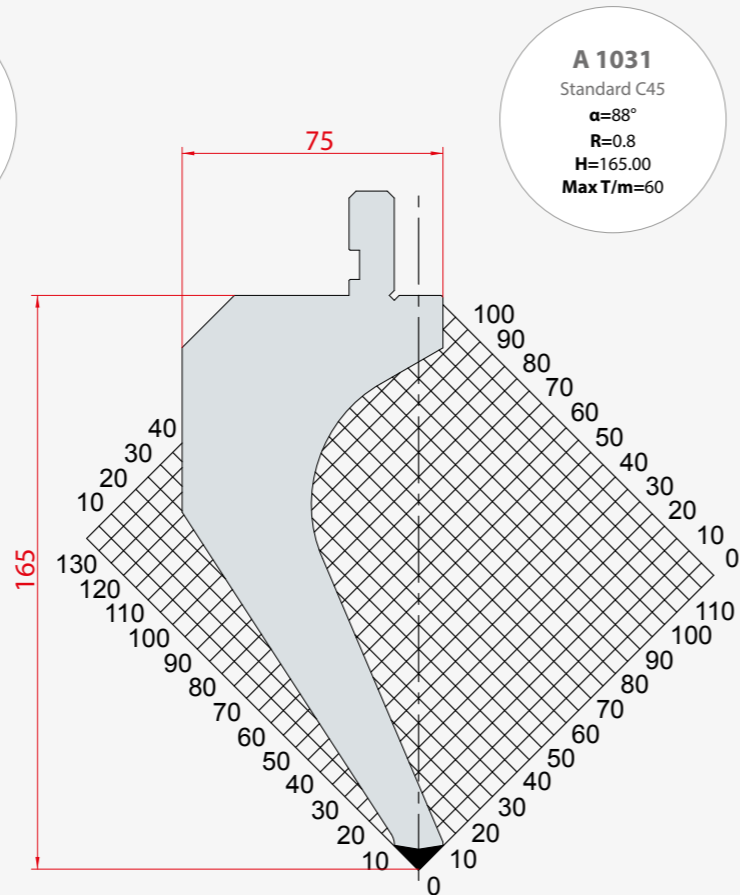
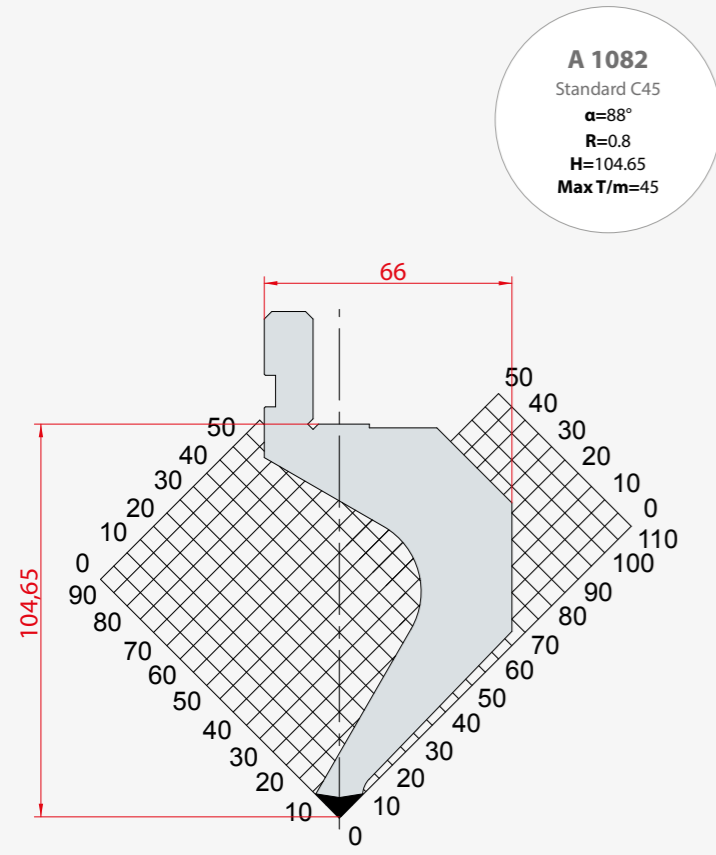
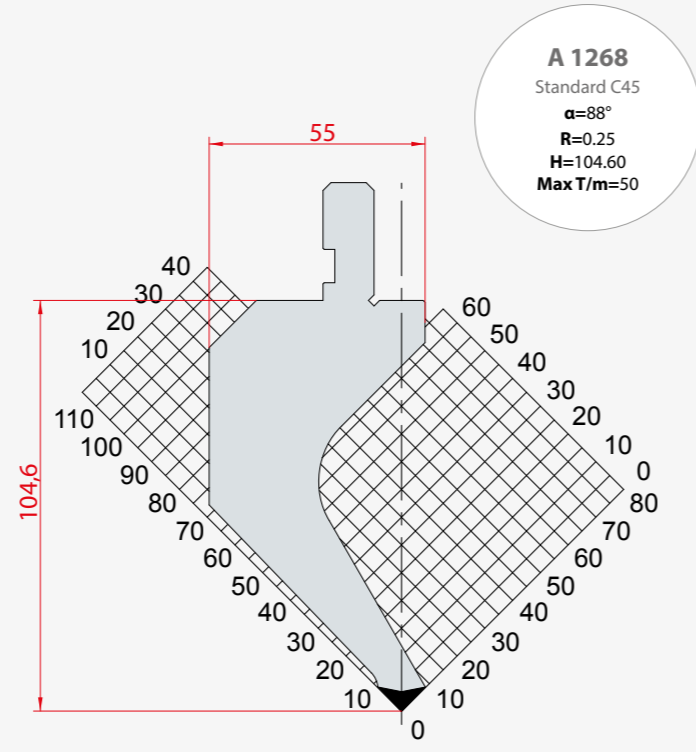
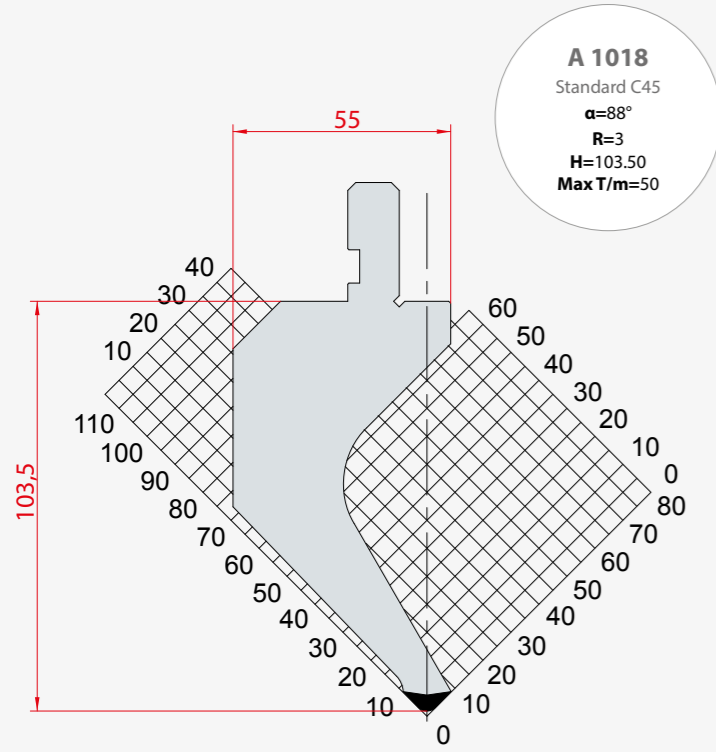

PUNCHES 88°

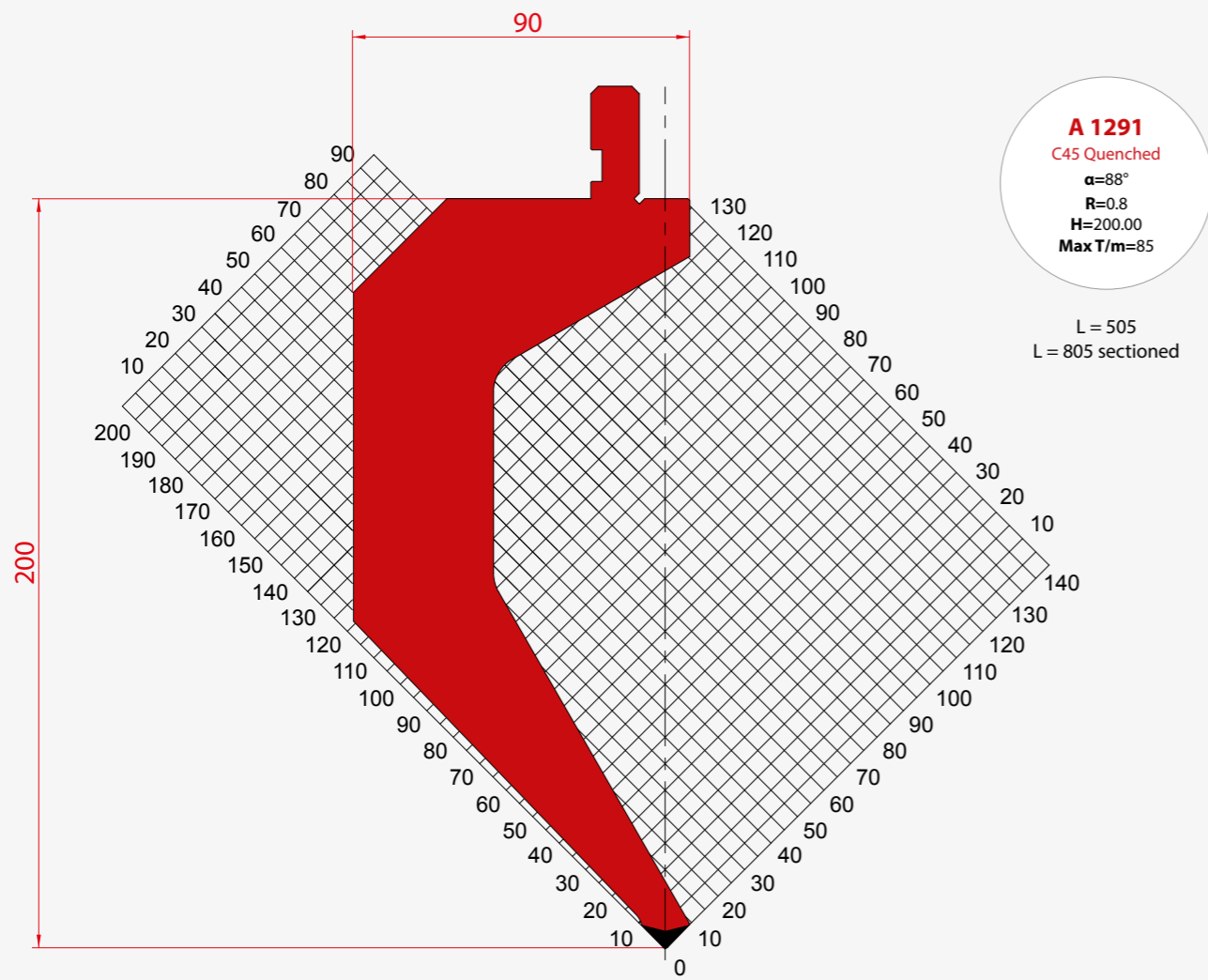
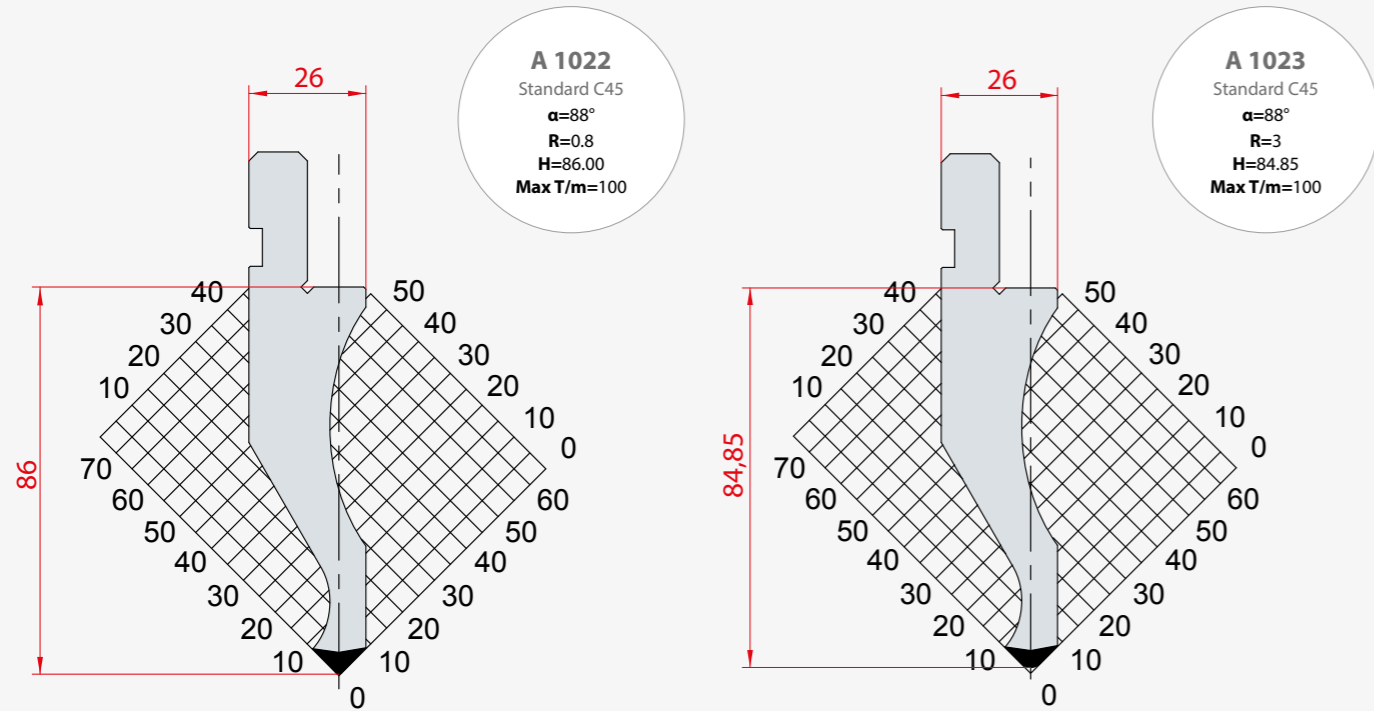

PUNCHES 88°

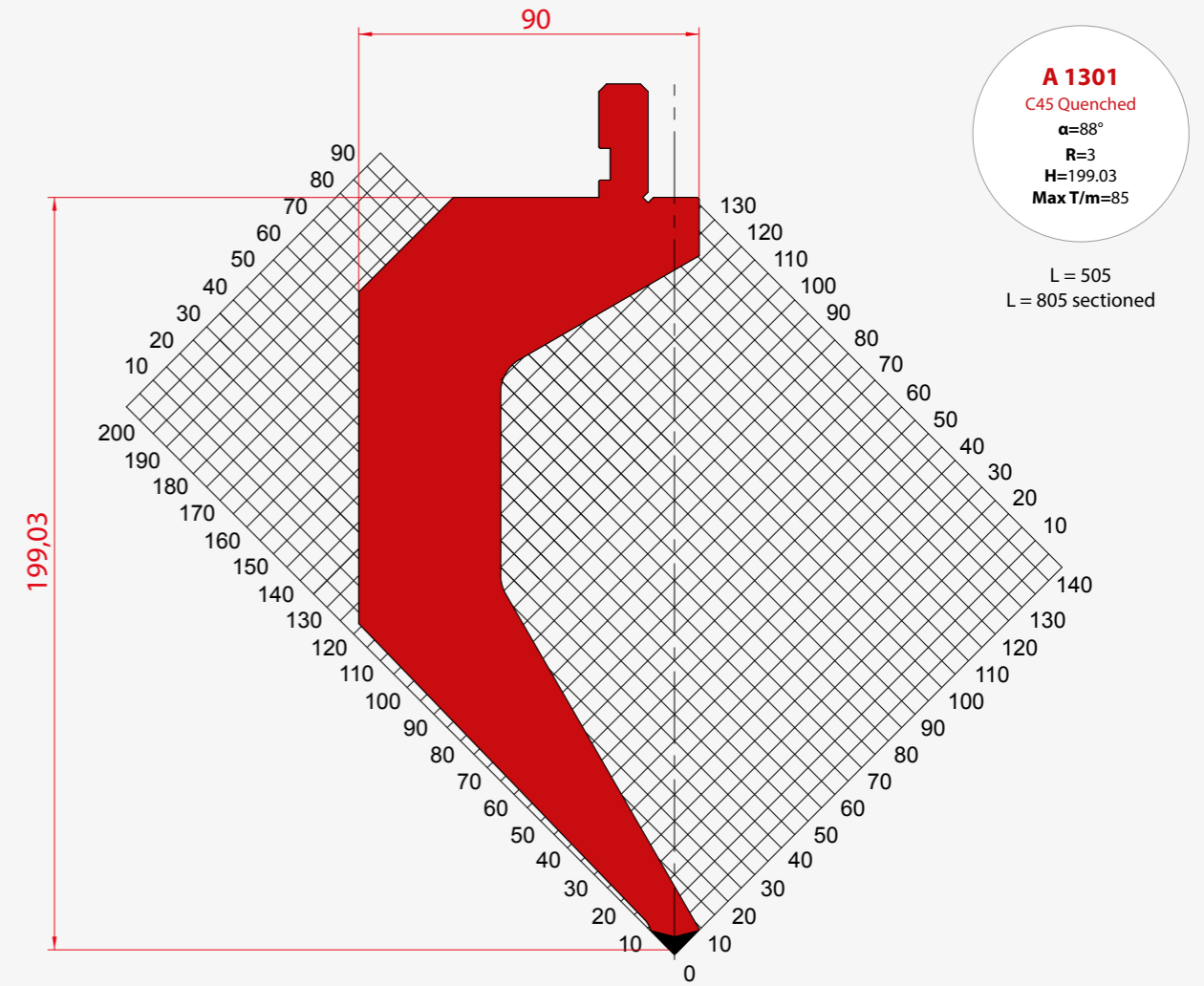

PUNCHES 85°

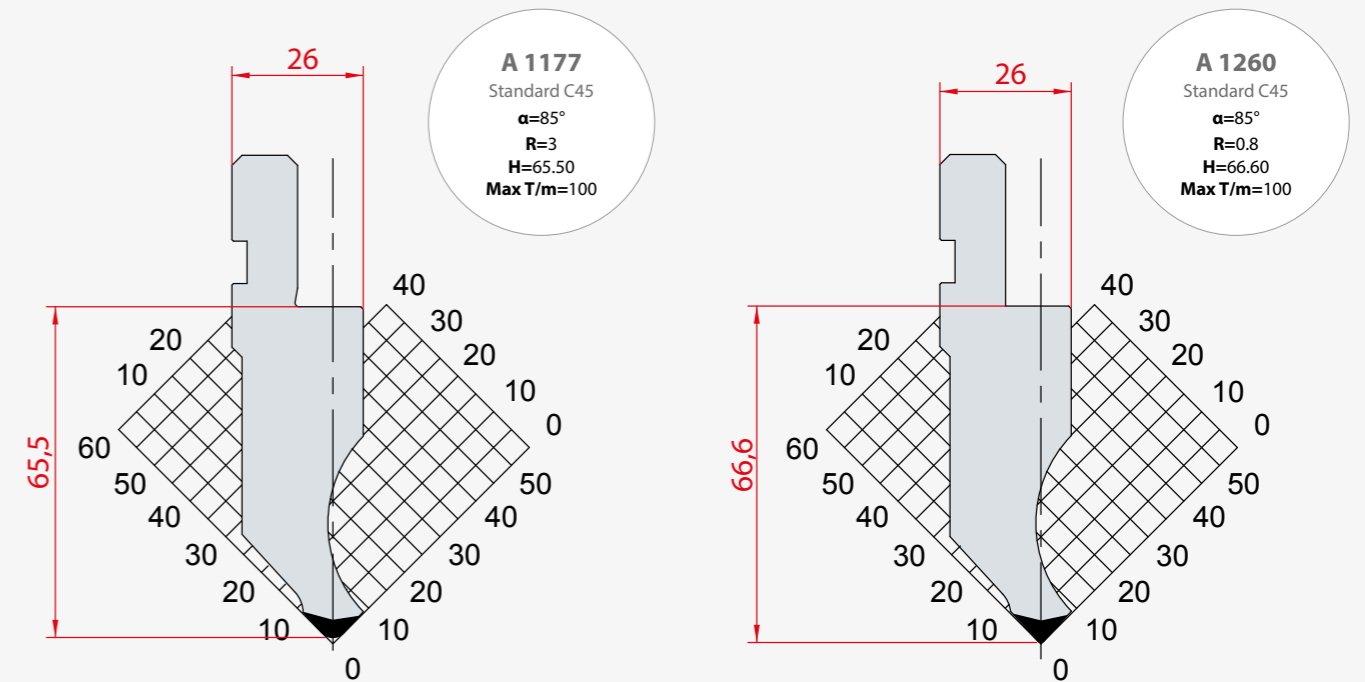

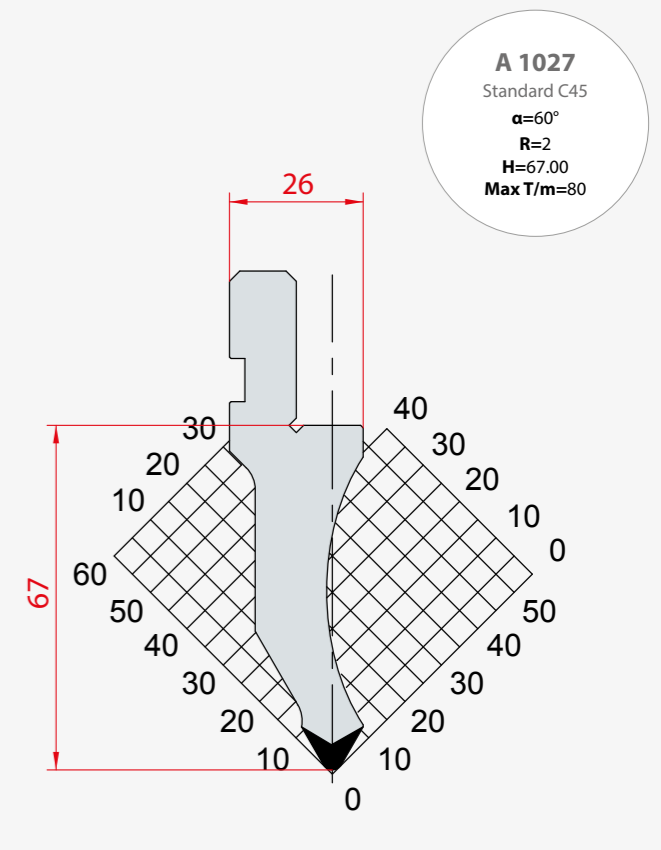
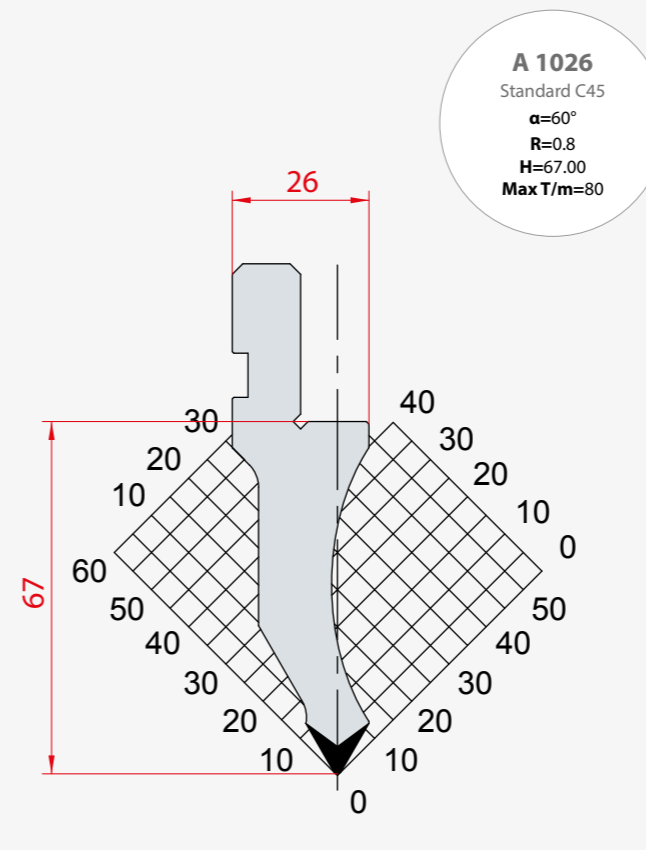
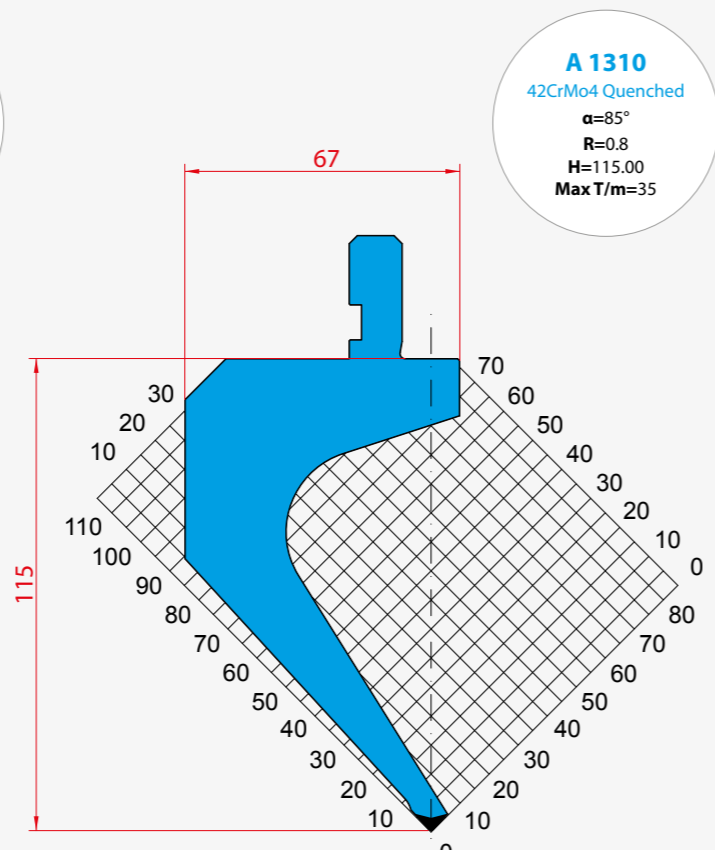
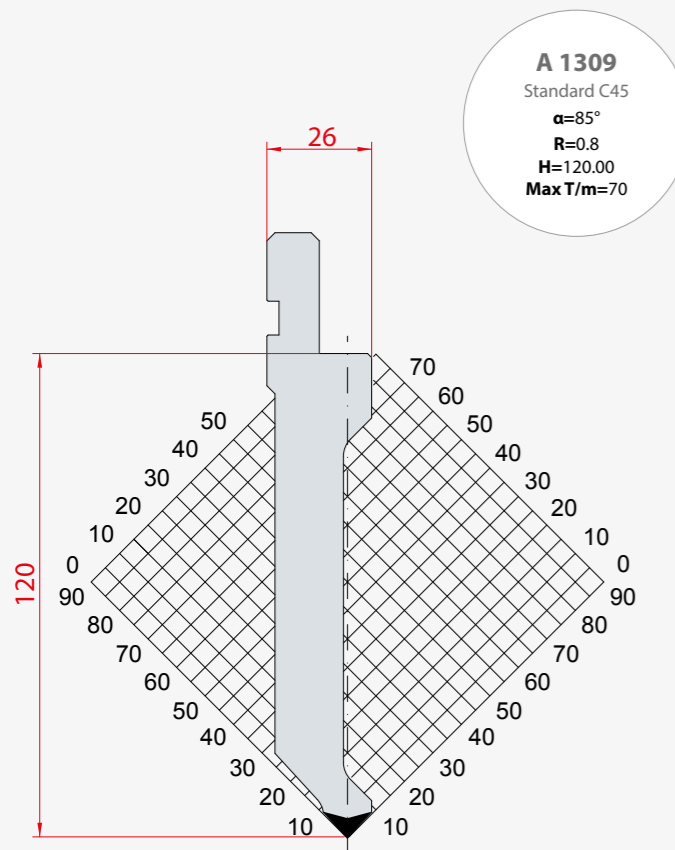
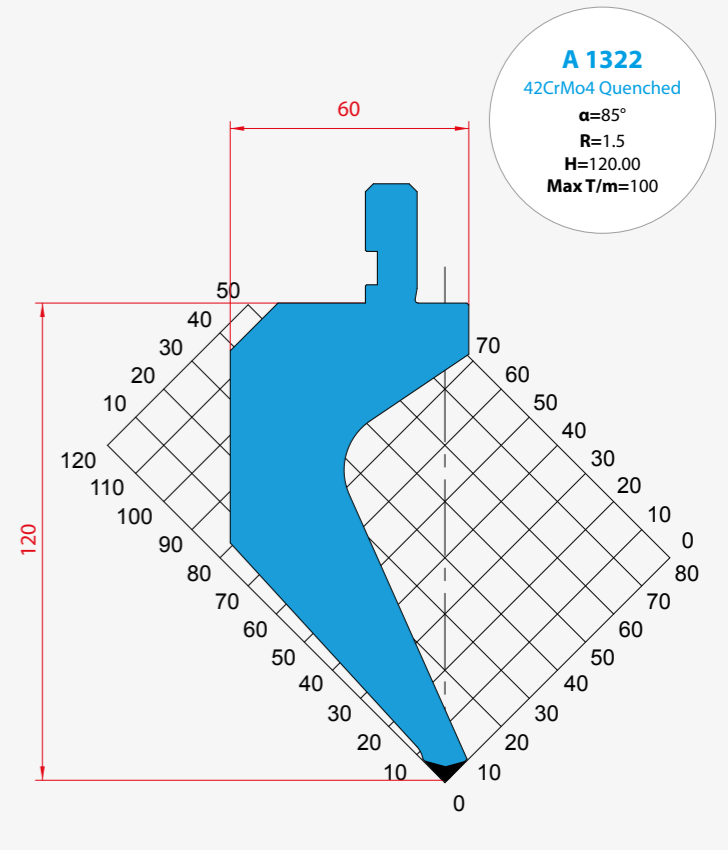
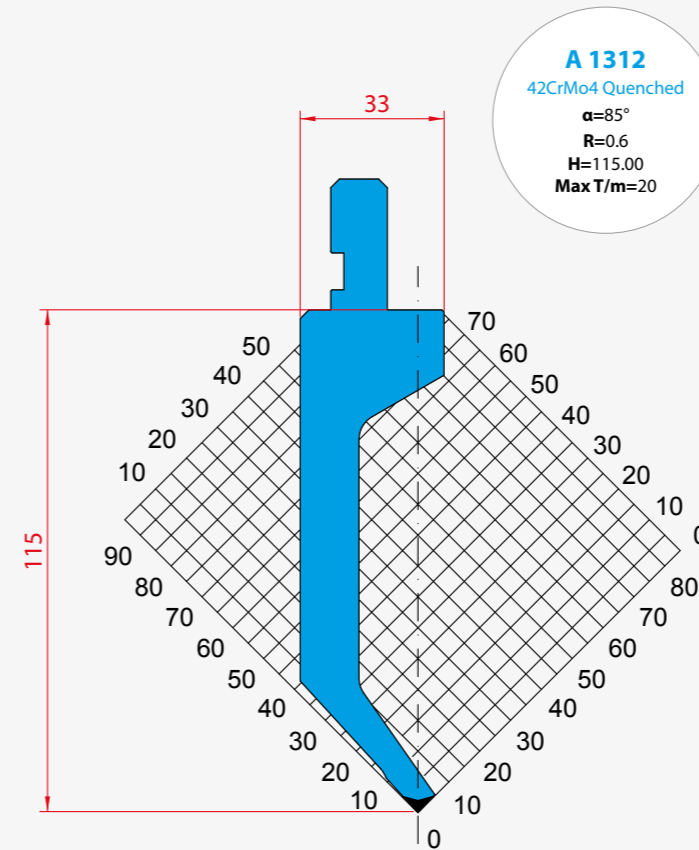
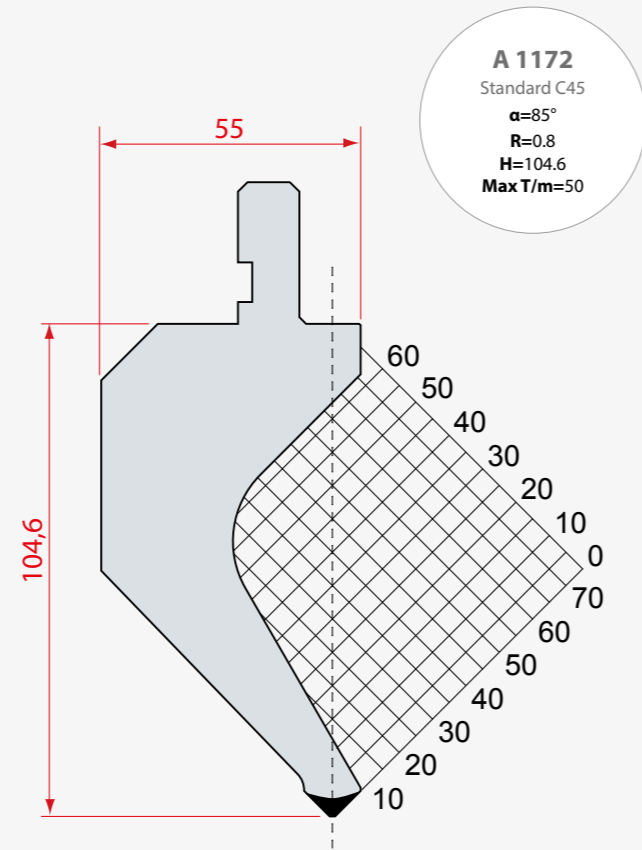
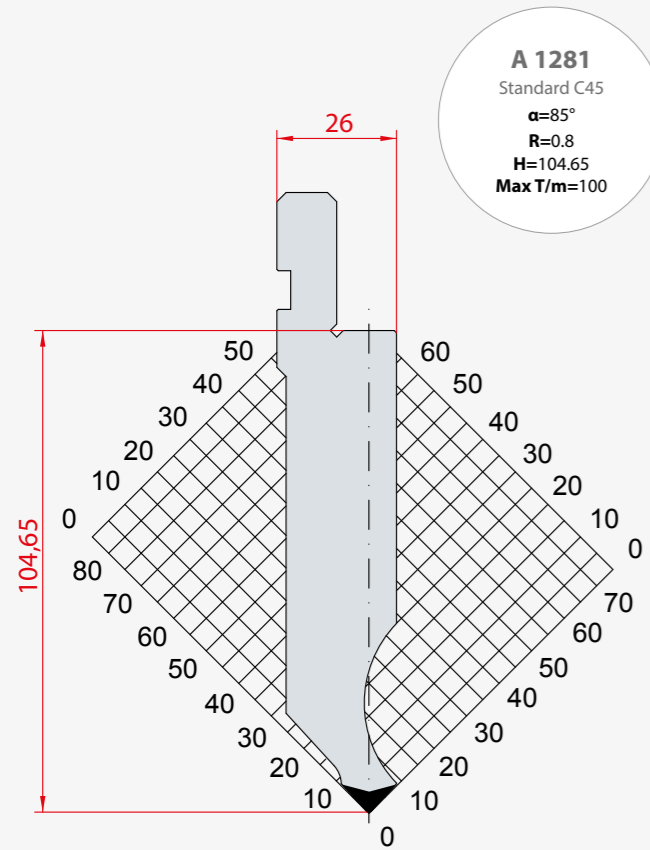

A 1191

Standard C45
 $\alpha=60^\circ$
 R=0.8
 H=115.00
 Max T/m=60

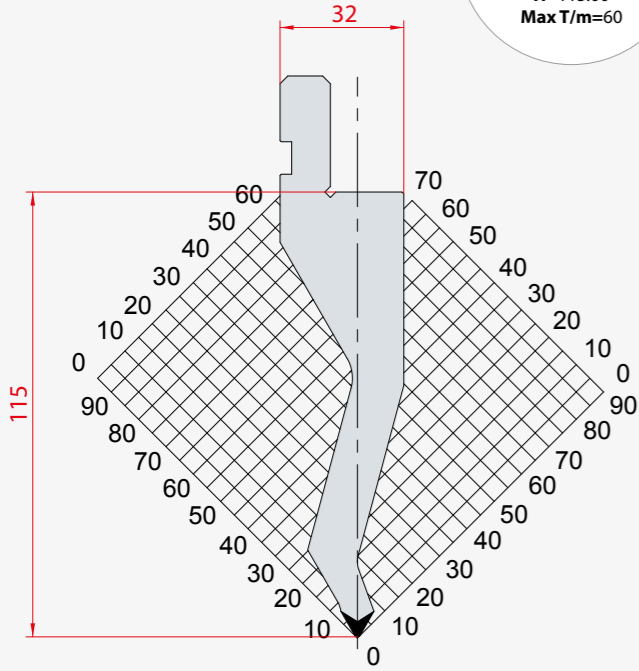

A 1190

C45 Quenched
 $\alpha=60^\circ$
 R=0.8
 H=160.00
 Max T/m=40

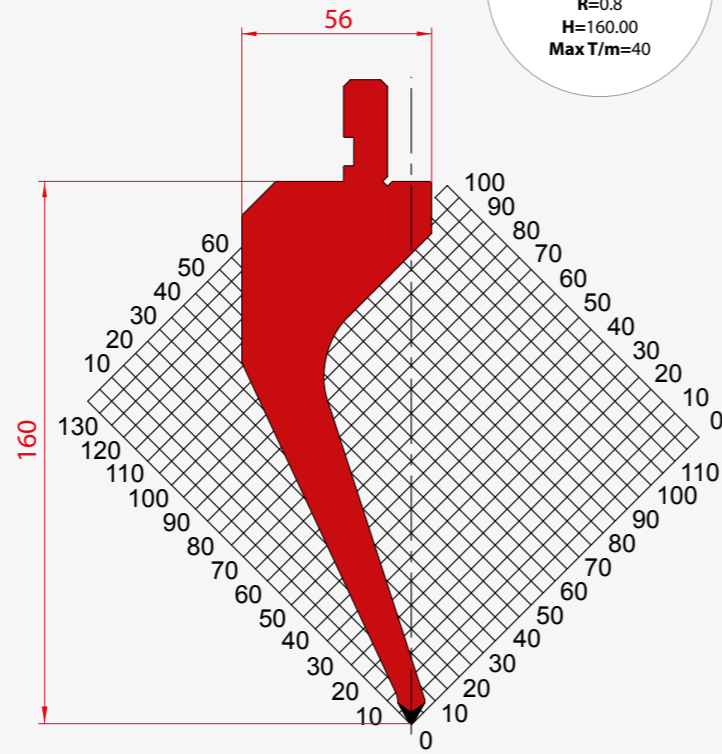

A 1272

C45 Quenched
 $\alpha=60^\circ$
 R=0.8
 H=115.00
 Max T/m=40

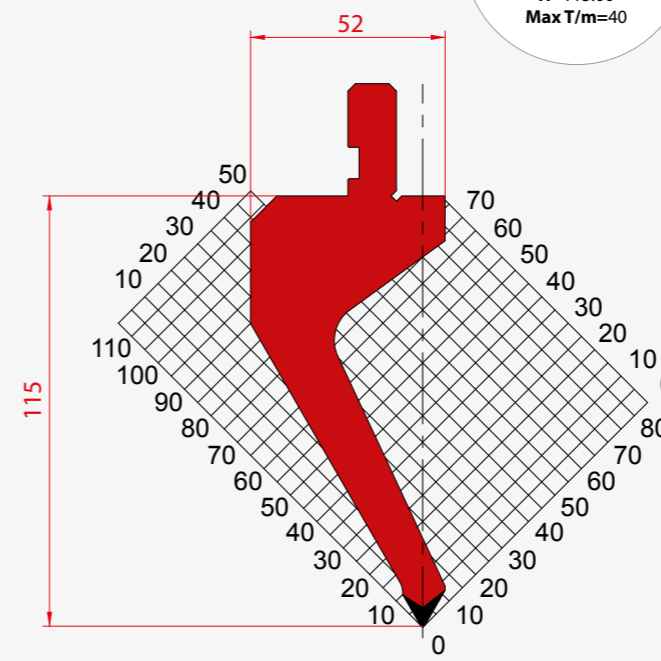

A 1271

C45 Quenched
 $\alpha=60^\circ$
 R=0.8
 H=115.00
 Max T/m=50

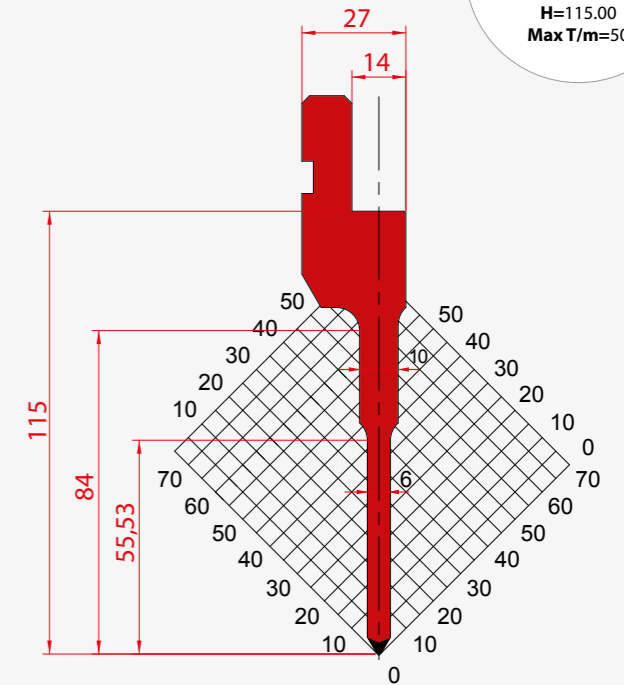

A 1162

42CrMo4 Quenched
 $\alpha=60^\circ$
 R=0.8
 H=85.00
 Max T/m=40

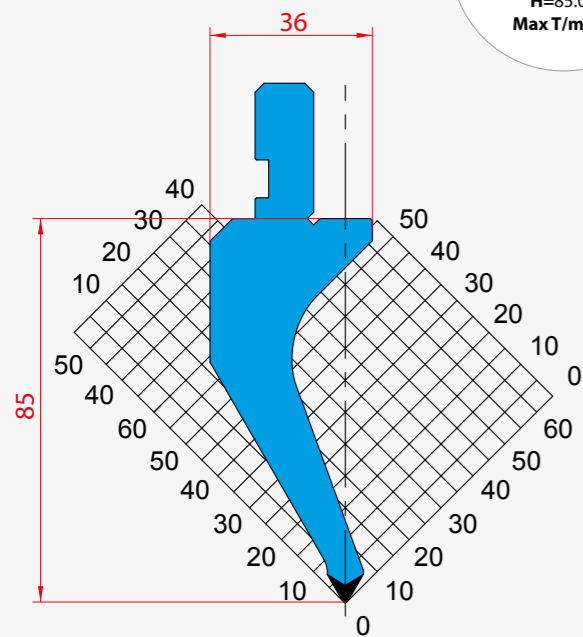

A 1163

C45 Quenched
 $\alpha=60^\circ$
 R=0.8
 H=130.00
 Max T/m=40

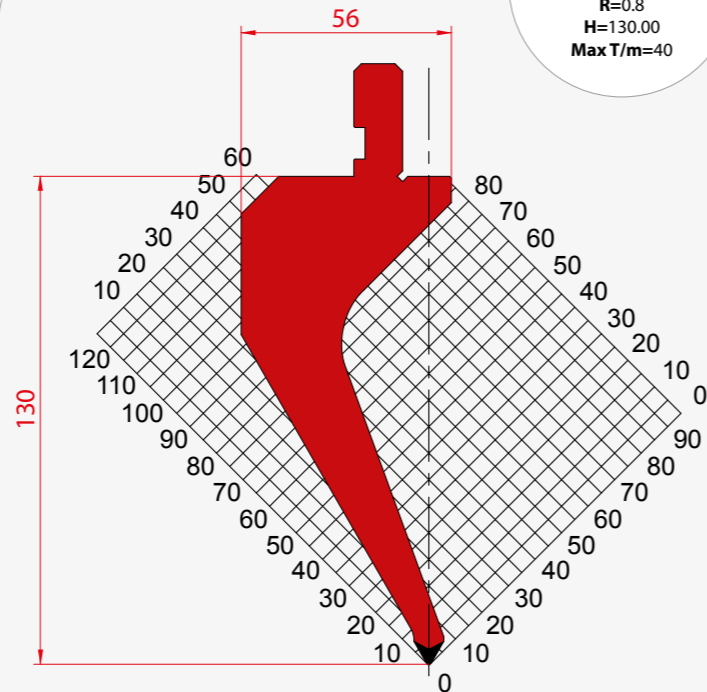

A 1032

Standard C45
 $\alpha=60^\circ$
 R=6
 H=65.00
 Max T/m=120

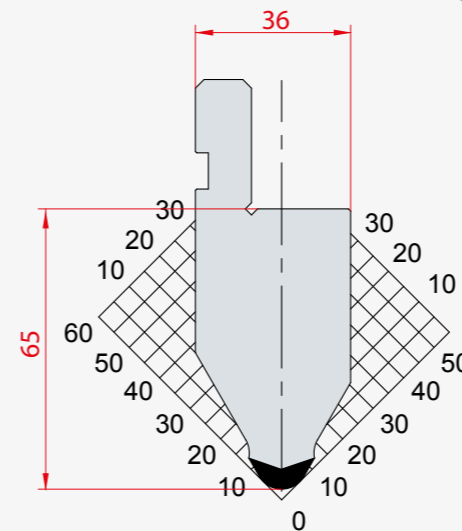

A 1283

Standard C45
 $\alpha=60^\circ$
 R=10
 H=115.00
 Max T/m=150

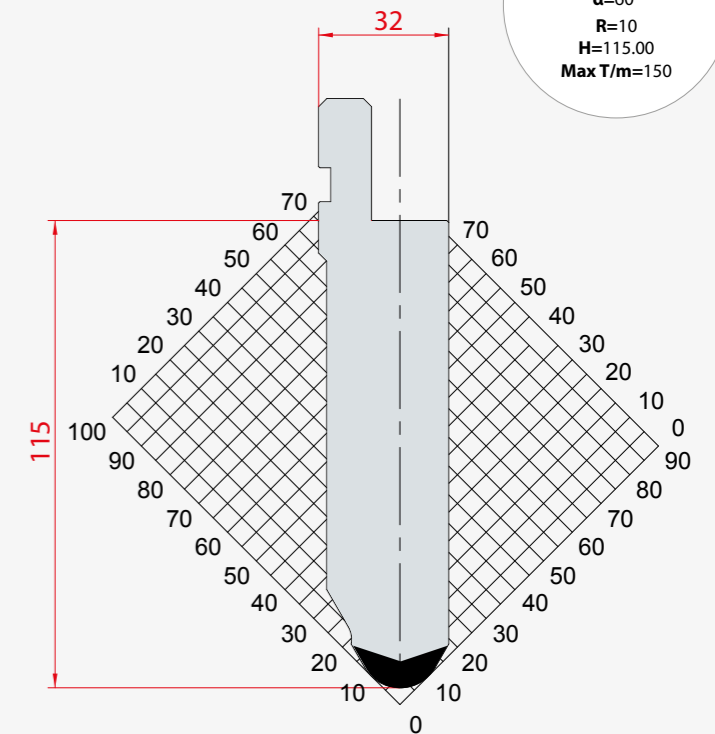

PUNCHES 60°

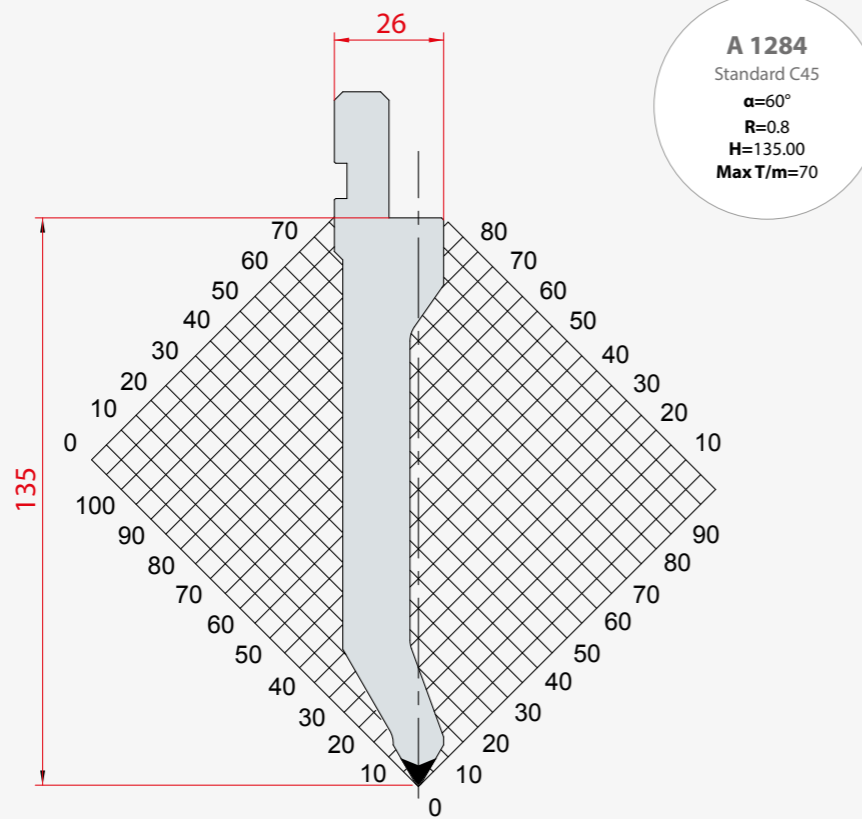
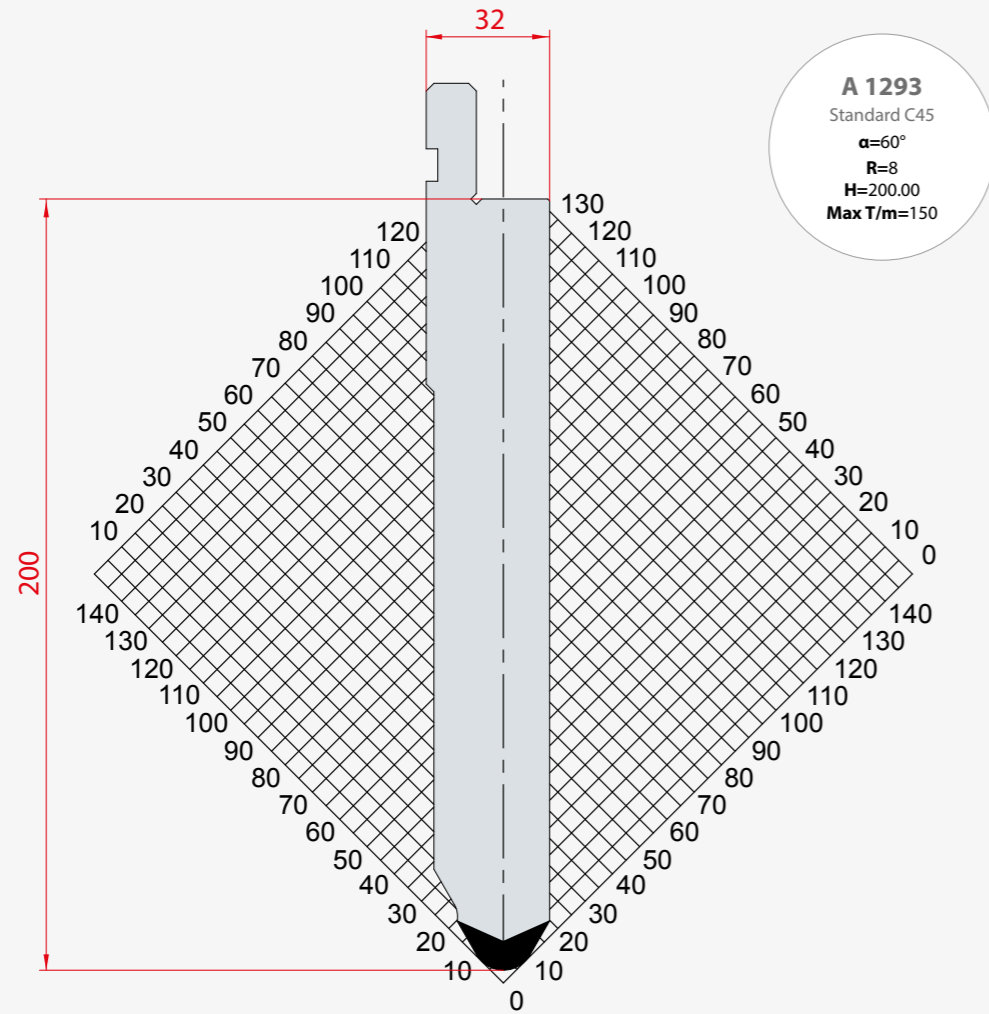

PUNCHES 45°

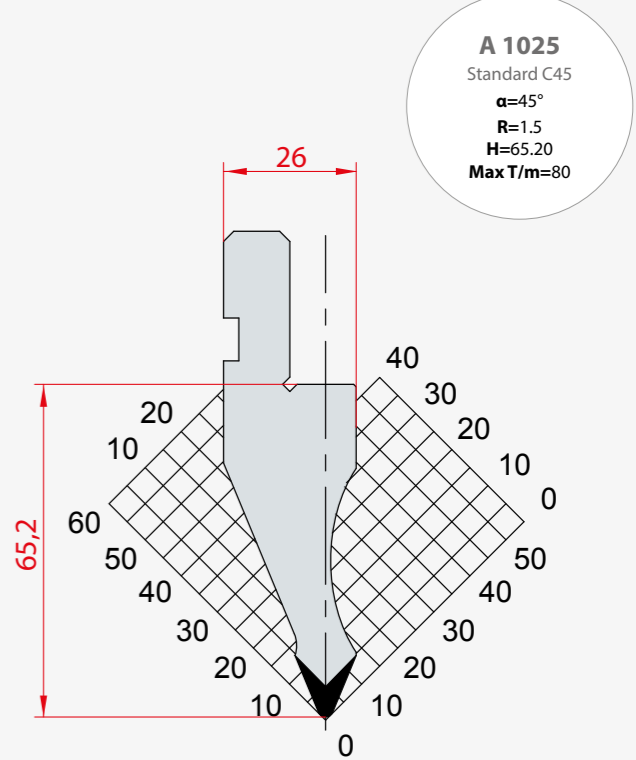
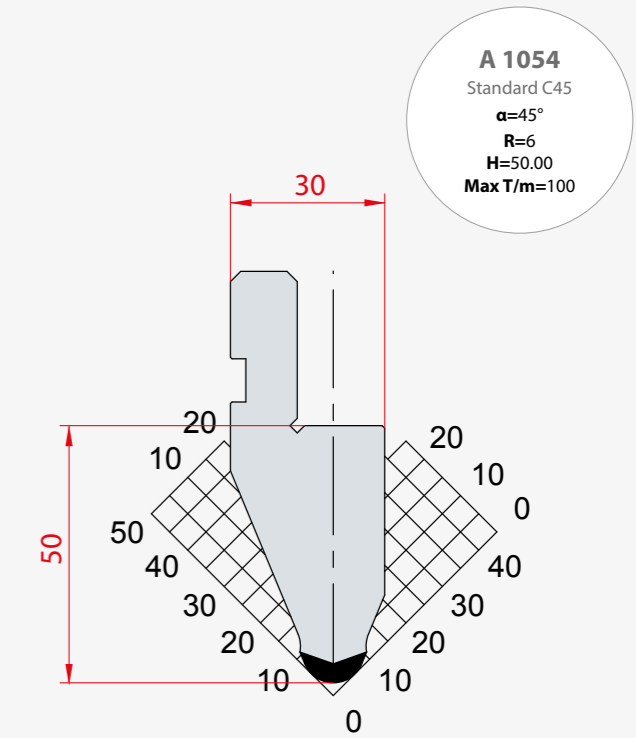
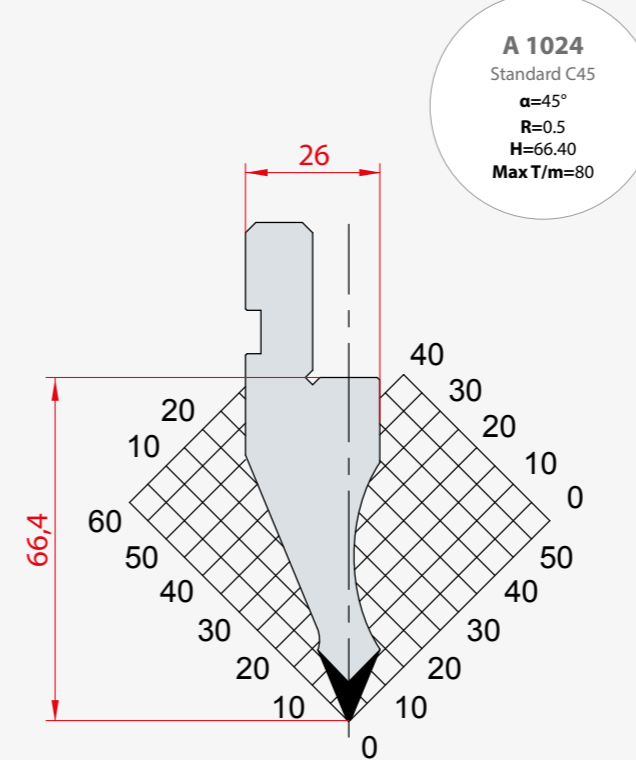
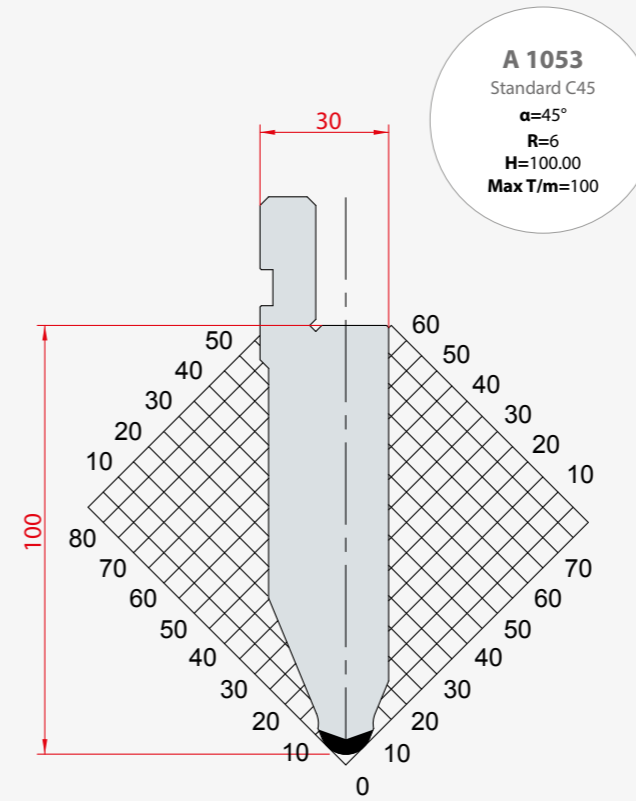

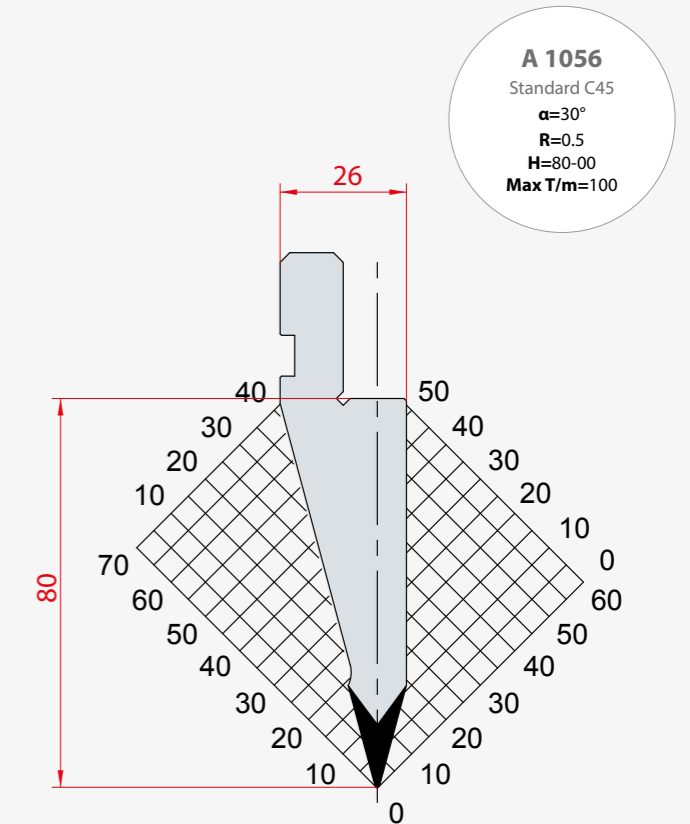
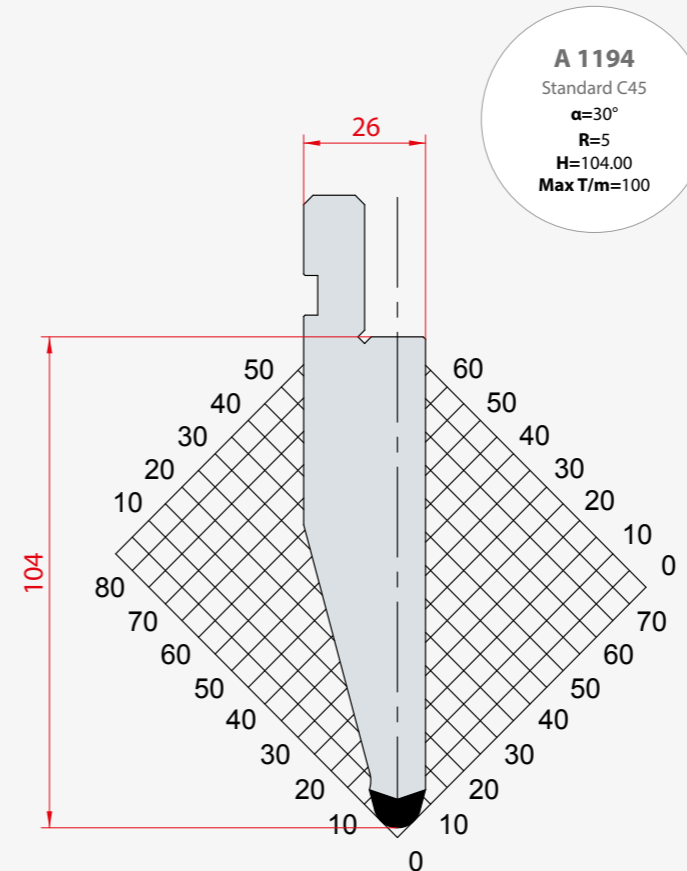
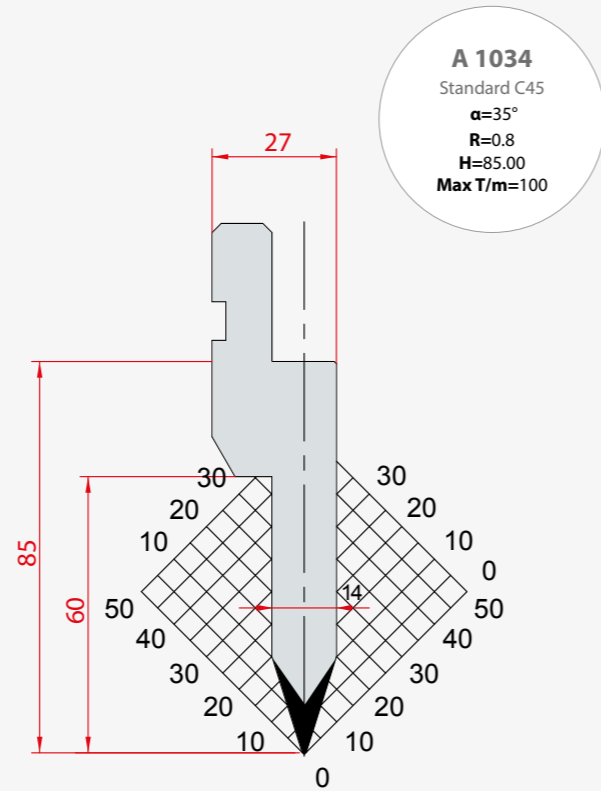
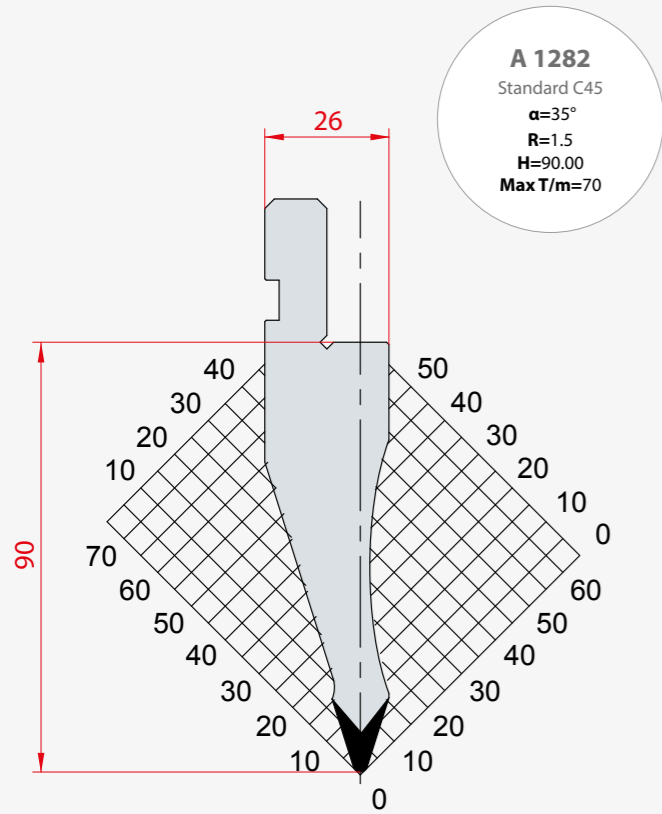
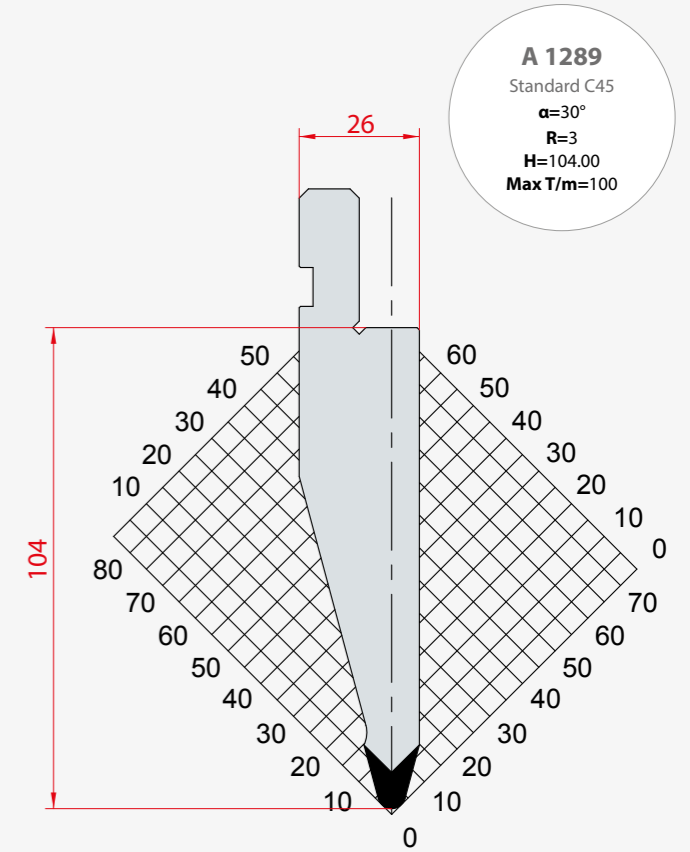
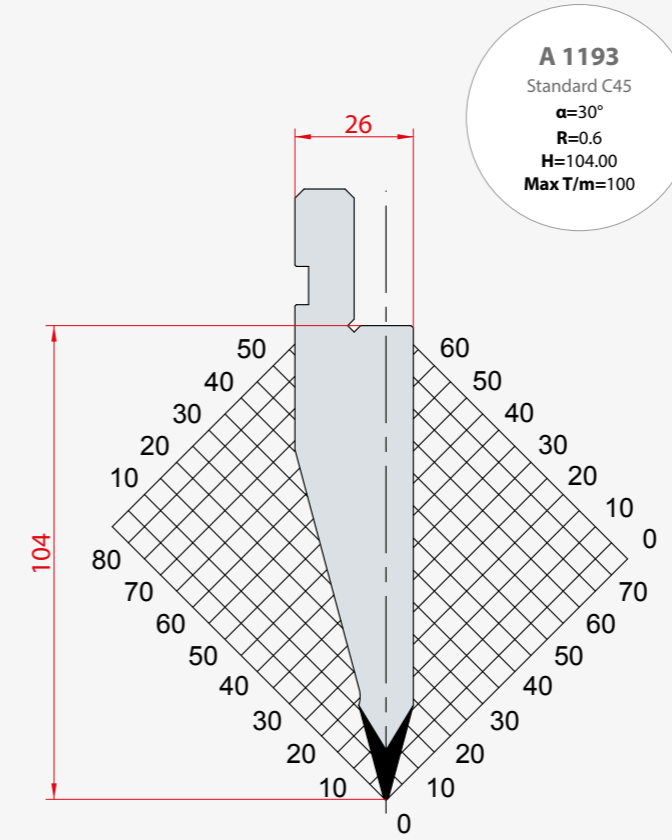
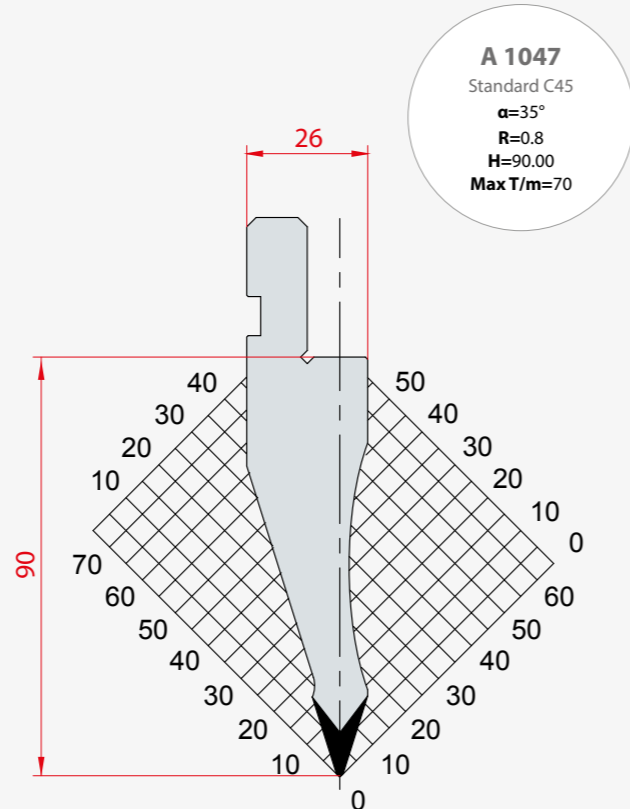
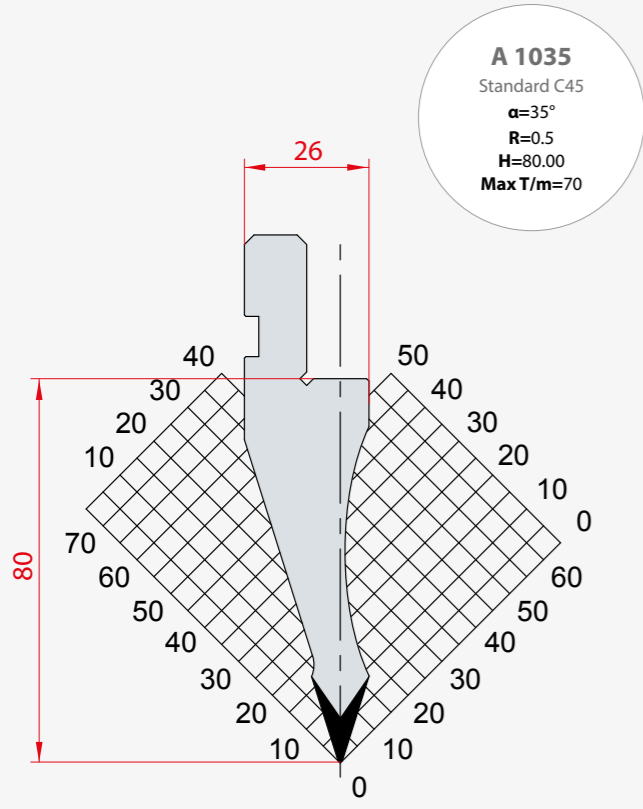

A 1057

Standard C45
 $\alpha=30^\circ$
 R=3
 H=80.00
 Max T/m=100

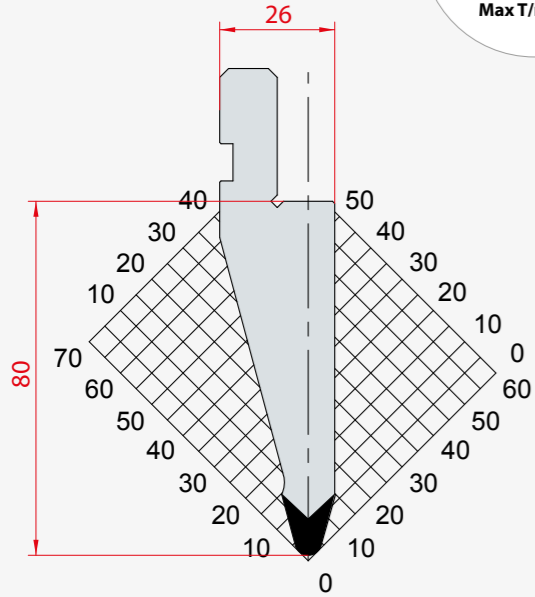

A 1086

C45 Quenched
 $\alpha=30^\circ$
 R=0.6
 H=140.00
 Max T/m=40

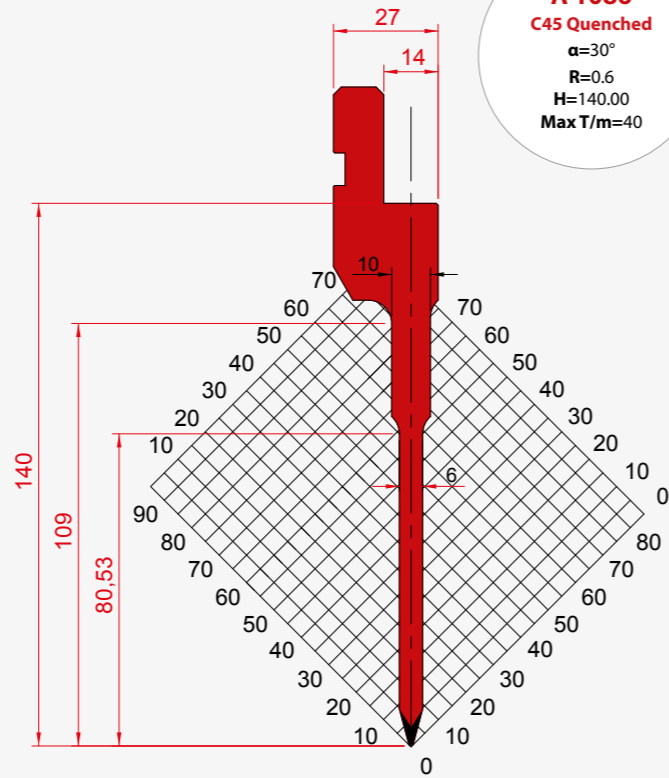

A 1052

Standard C45
 $\alpha=30^\circ$
 R=0.5
 H=135.00
 Max T/m=50

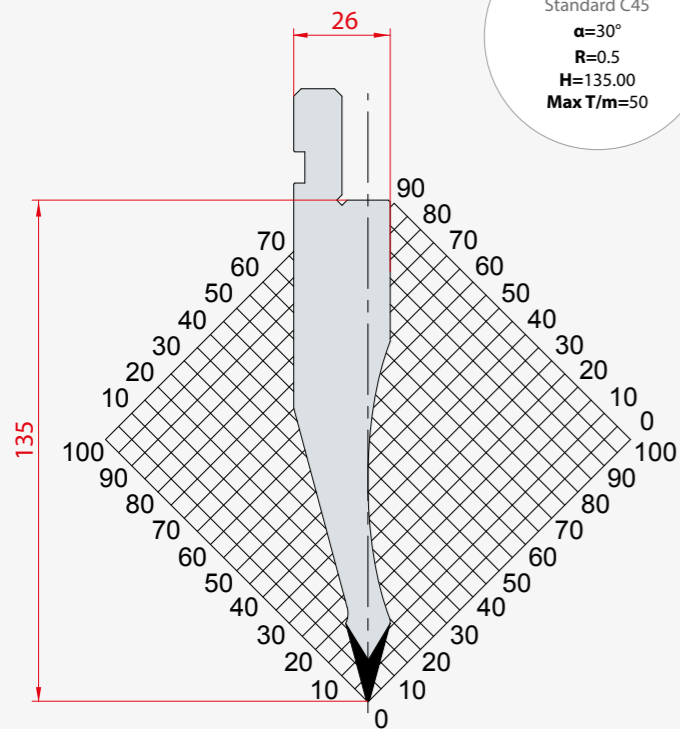

A 1055

Standard C45
 $\alpha=30^\circ$
 R=0.5
 H=105.00
 Max T/m=50

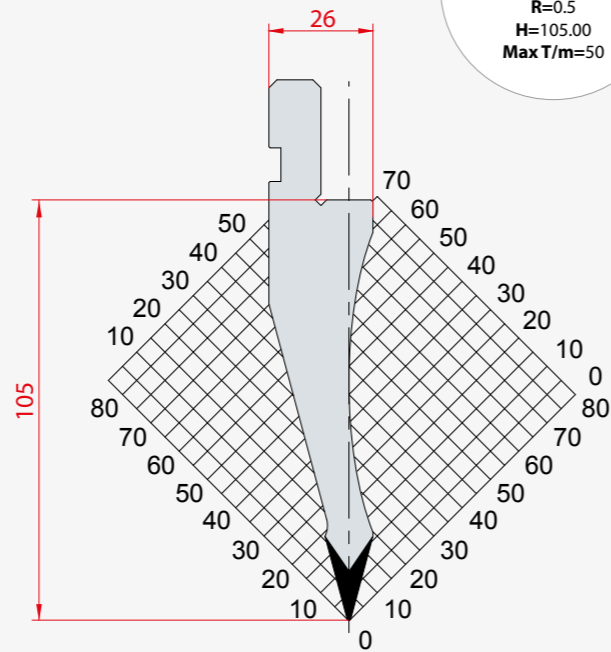

A 1292

Standard C45
 $\alpha=30^\circ$
 R=0.5
 H=200.00
 Max T/m=50

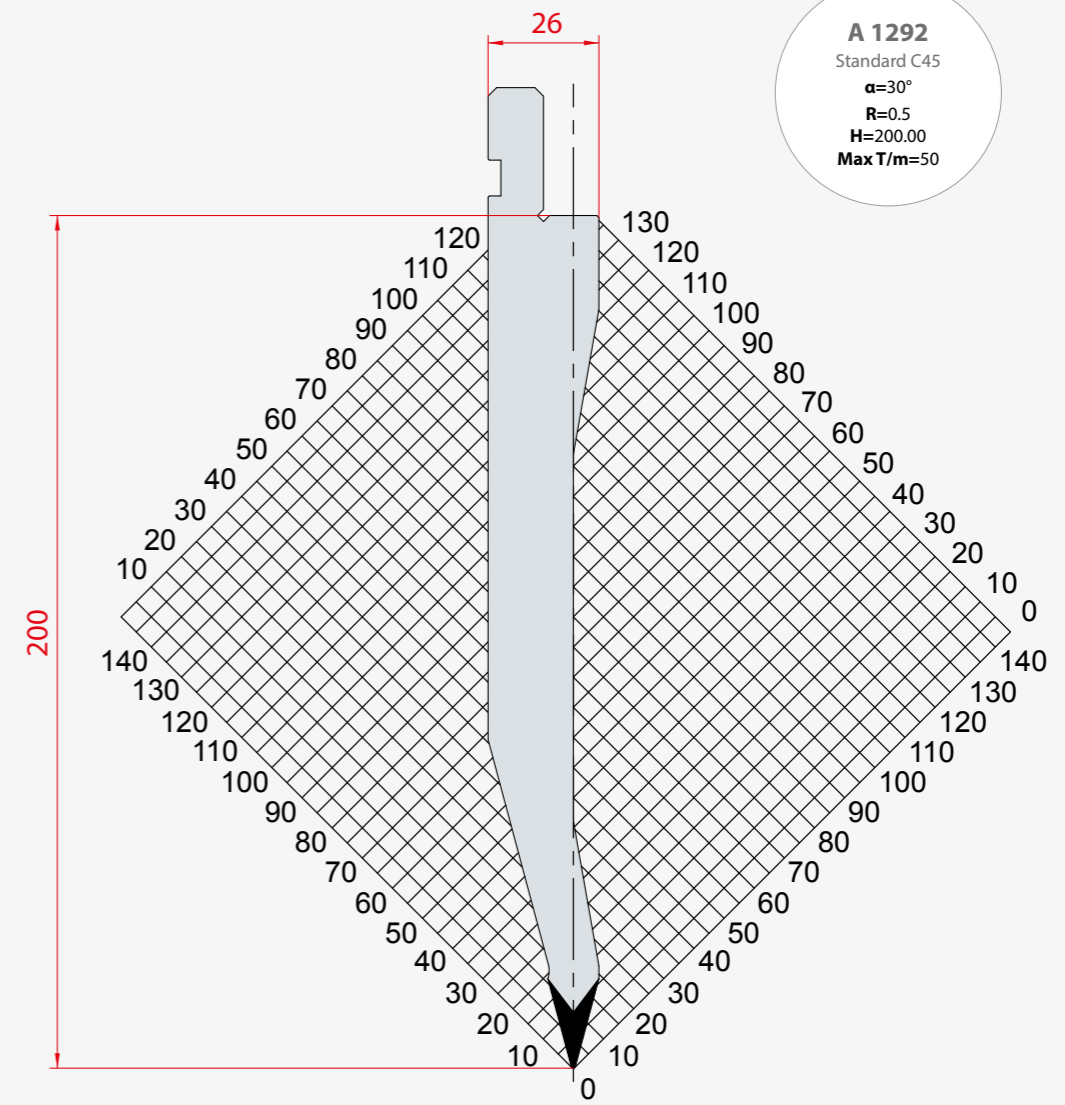

A 1033

Standard C45
 $\alpha=26^\circ$
 R=1
 H=117.00
 Max T/m=100

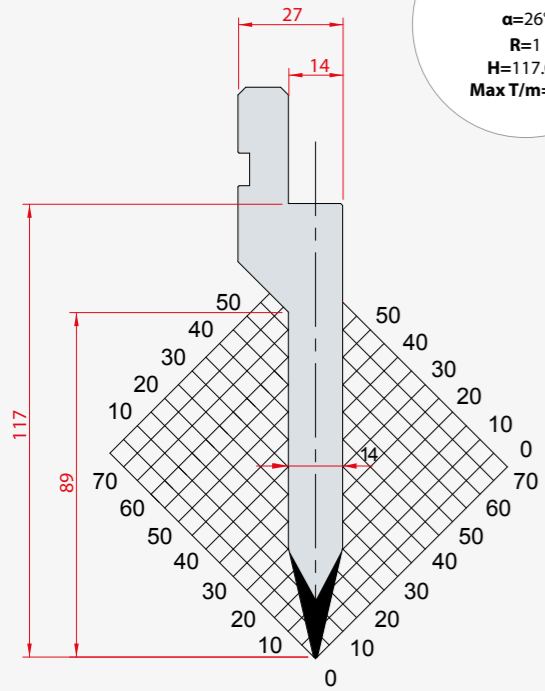

A 1178

Standard C45
 $\alpha=26^\circ$
 R=0.8
 H=117.00
 Max T/m=100

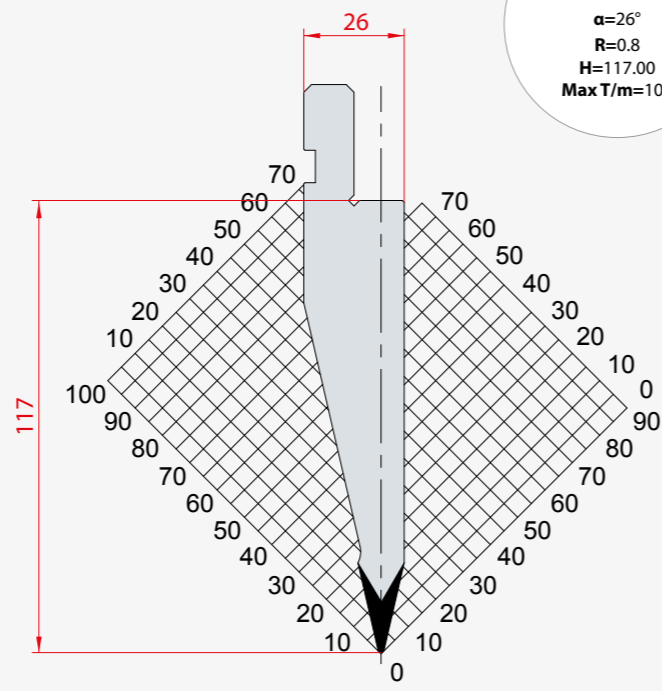

A 1192

Standard C45
 $\alpha=26^\circ$
 R=3
 H=117.00
 Max T/m=100

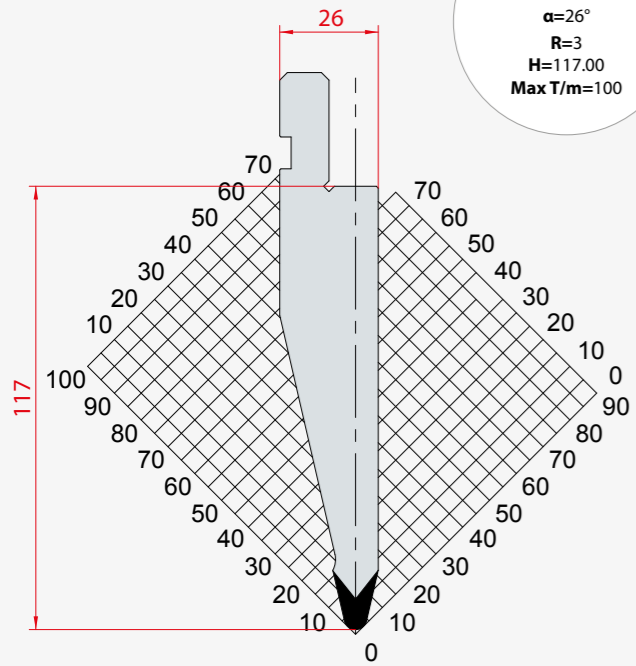

A 1311

42CrMo4 Quenched
 $\alpha=26^\circ$
 R=0.8
 H=145.00
 Max T/m=100

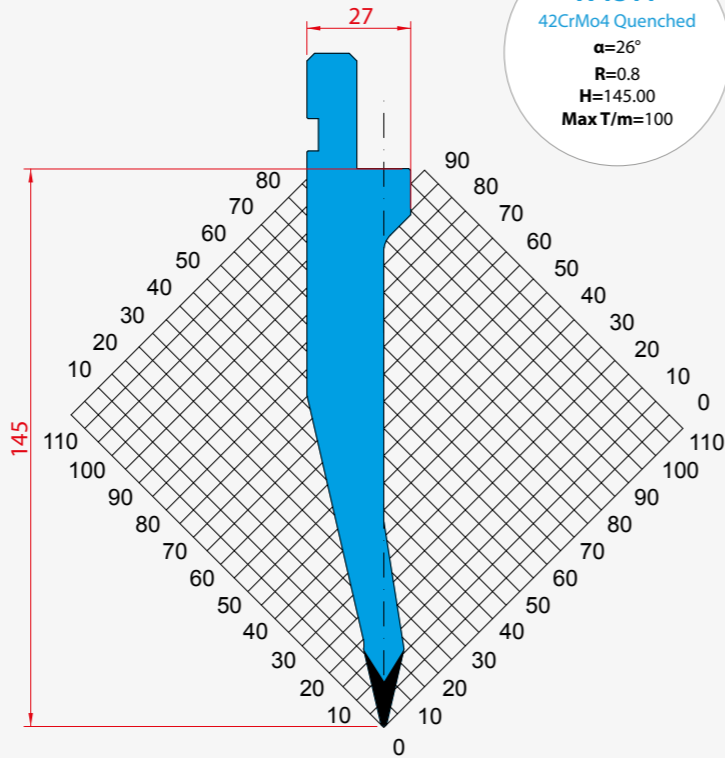

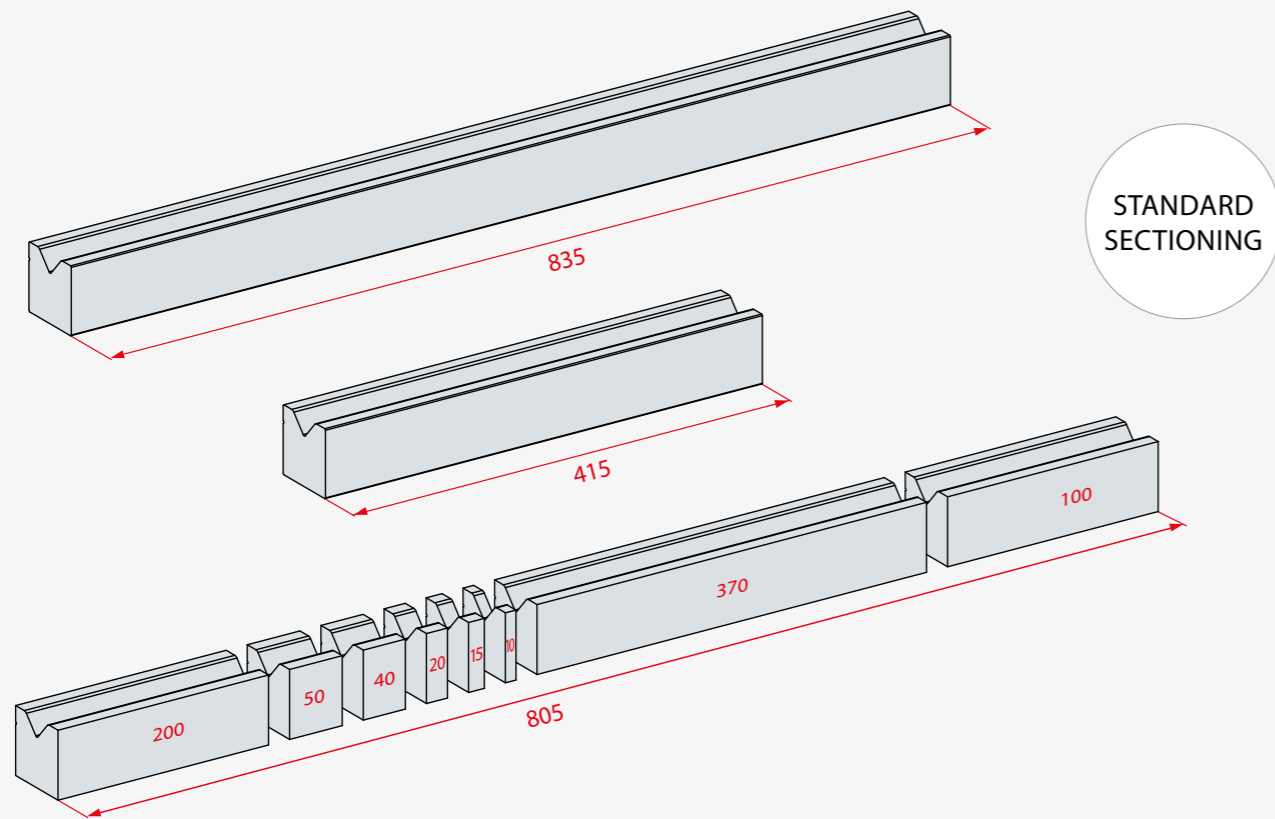

SPECIAL SEGMENTATION

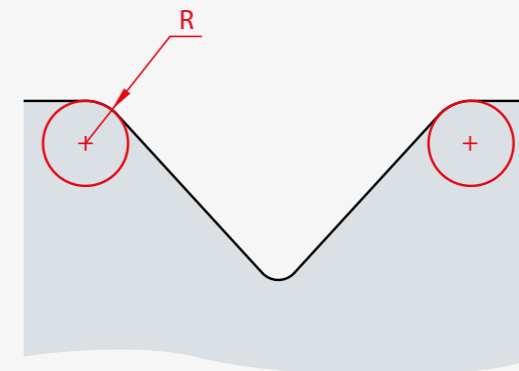

RADIUS MODIFICATION

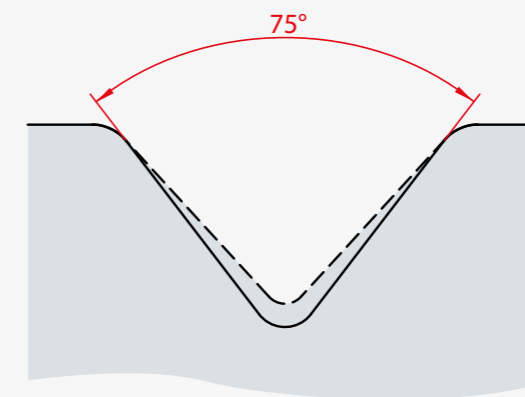

ANGLE MODIFICATION

induction hardened

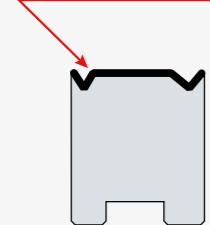

induction hardened

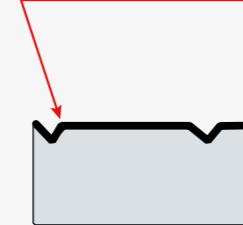

STANDARD LENGTHS

induction hardened

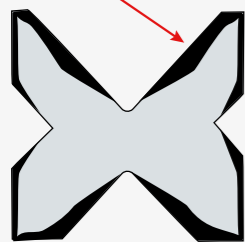

induction hardened

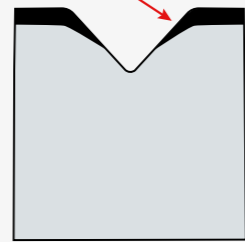

induction hardened

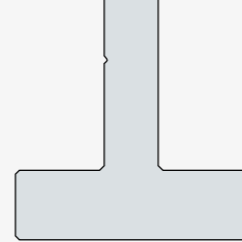

MATERIAL TYPE:

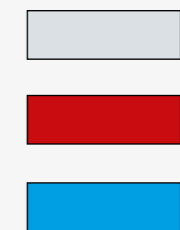

Standard C45

C45 Quenched

42CrMo4 Quenched

4V L DIES

1V DIES 85°

85°
88°

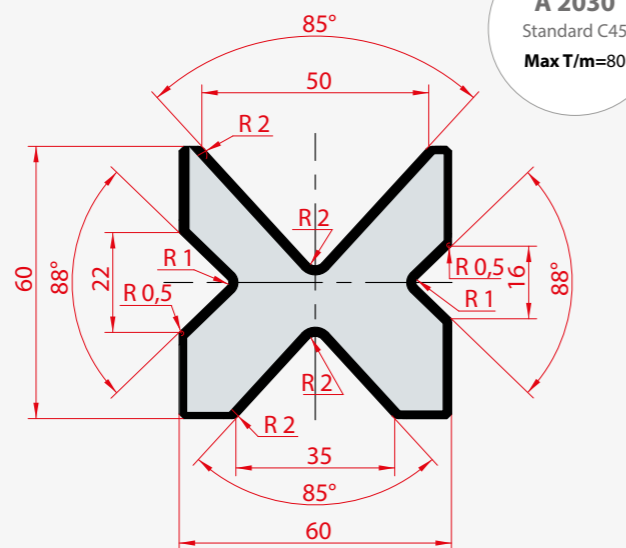

85°

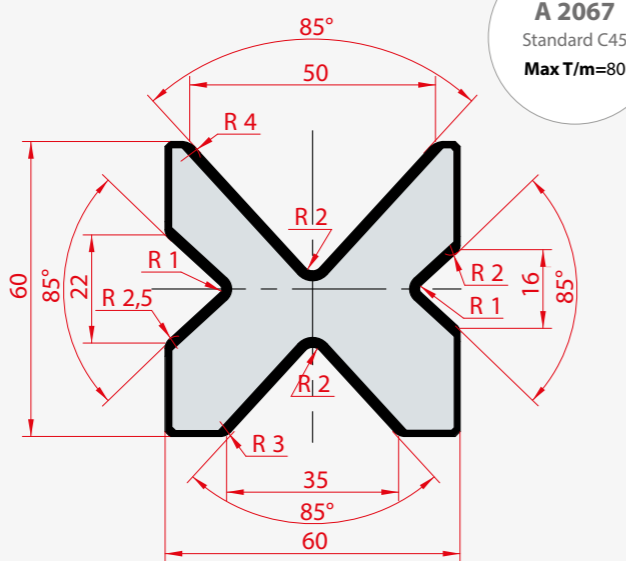

60°

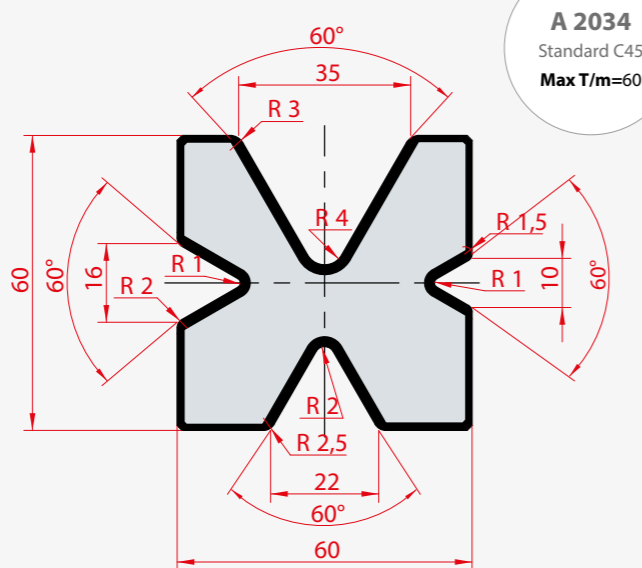

A 2020
Standard C45
Max T/m=100

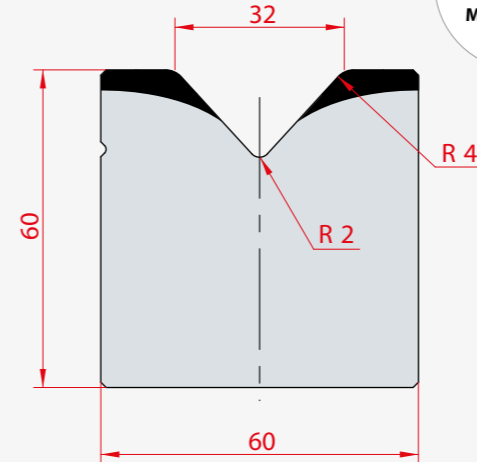

A 2021
Standard C45
Max T/m=100

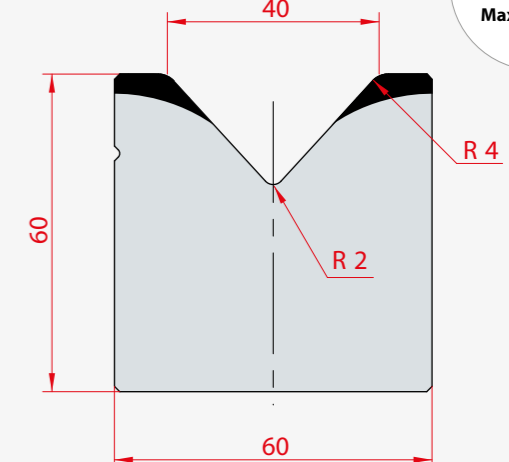

A 2022
Standard C45
Max T/m=80

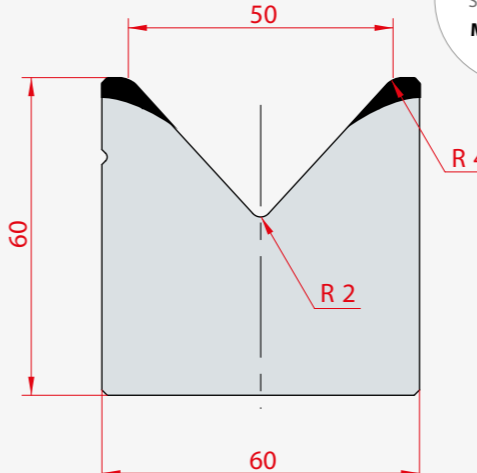

A 2023
Standard C45
Max T/m=100

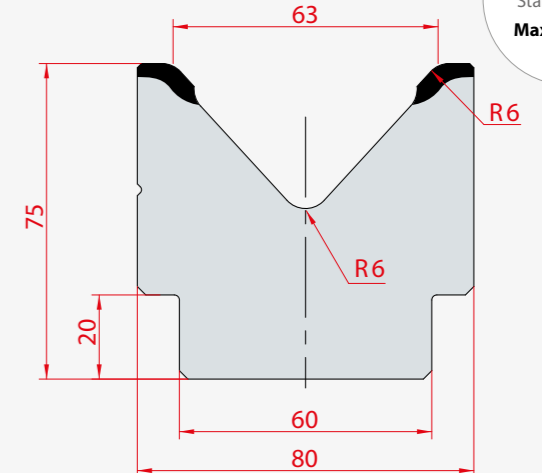

A 2024
Standard C45
Max T/m=100

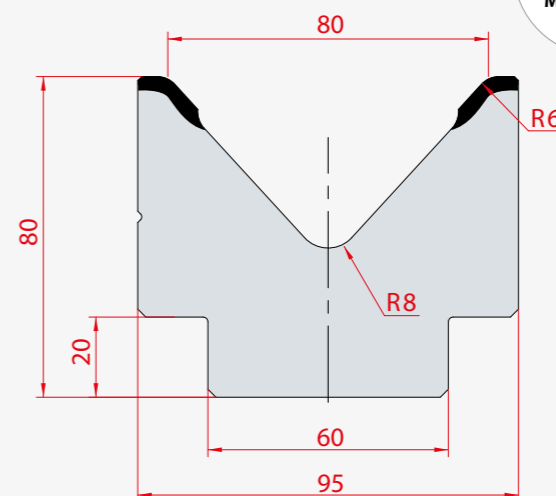

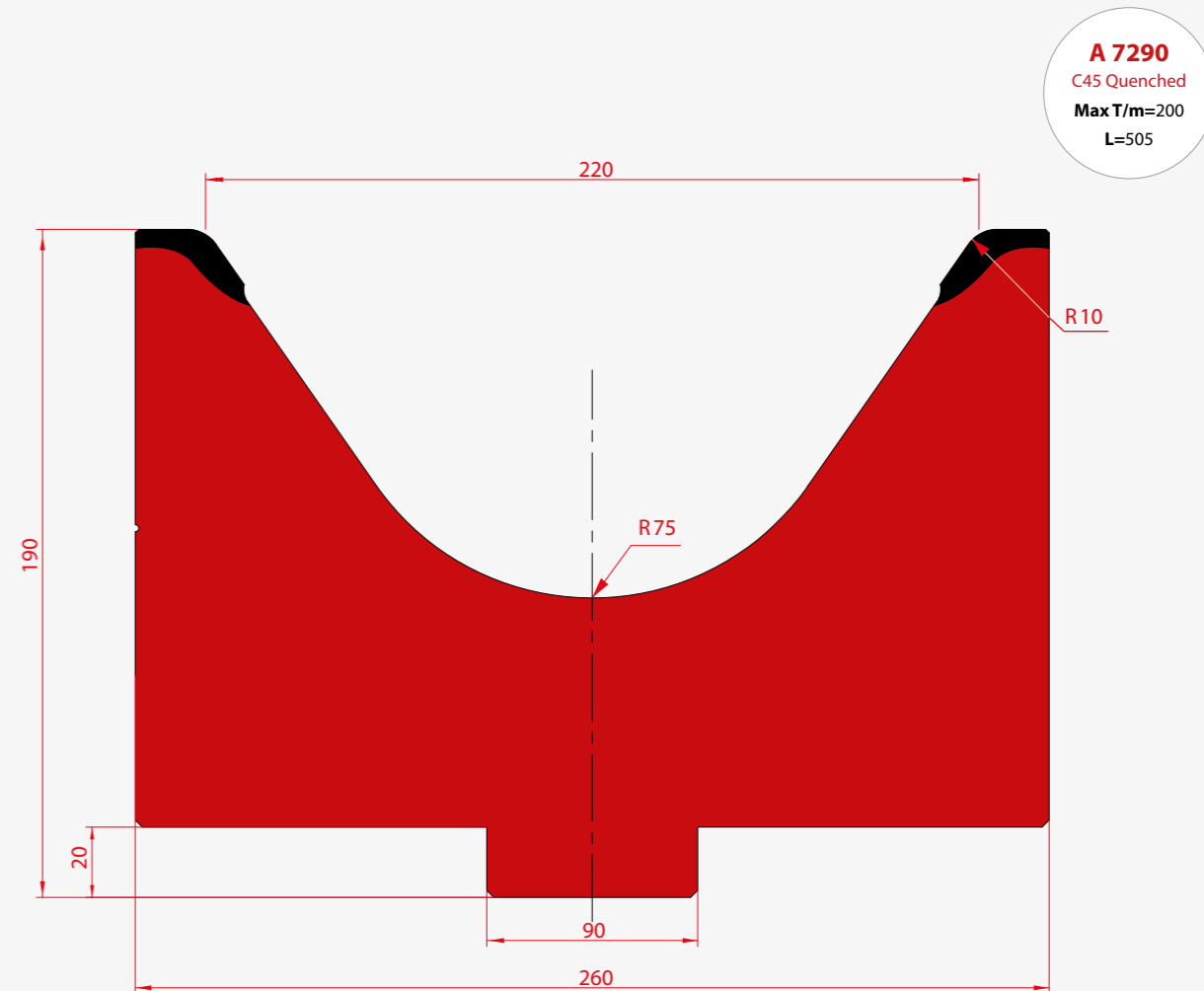
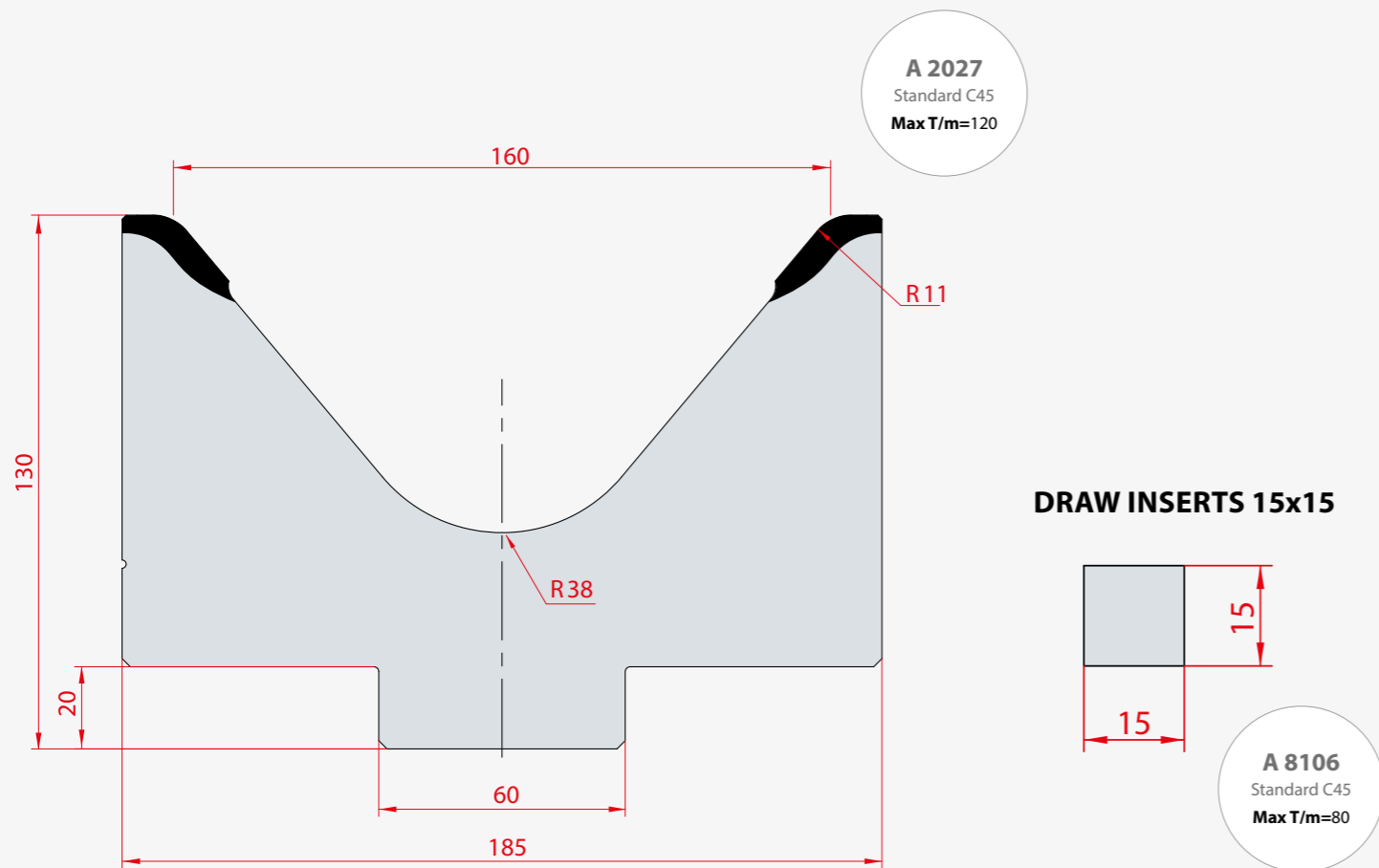
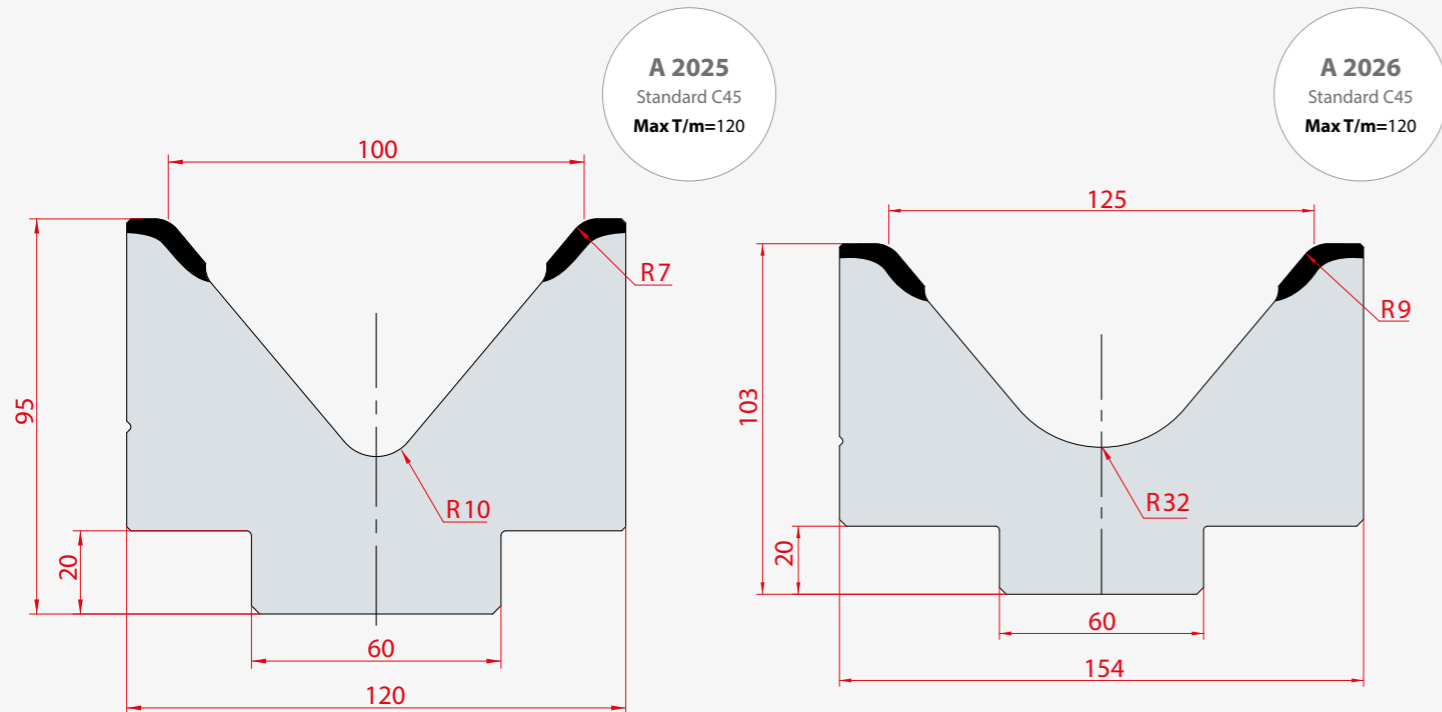

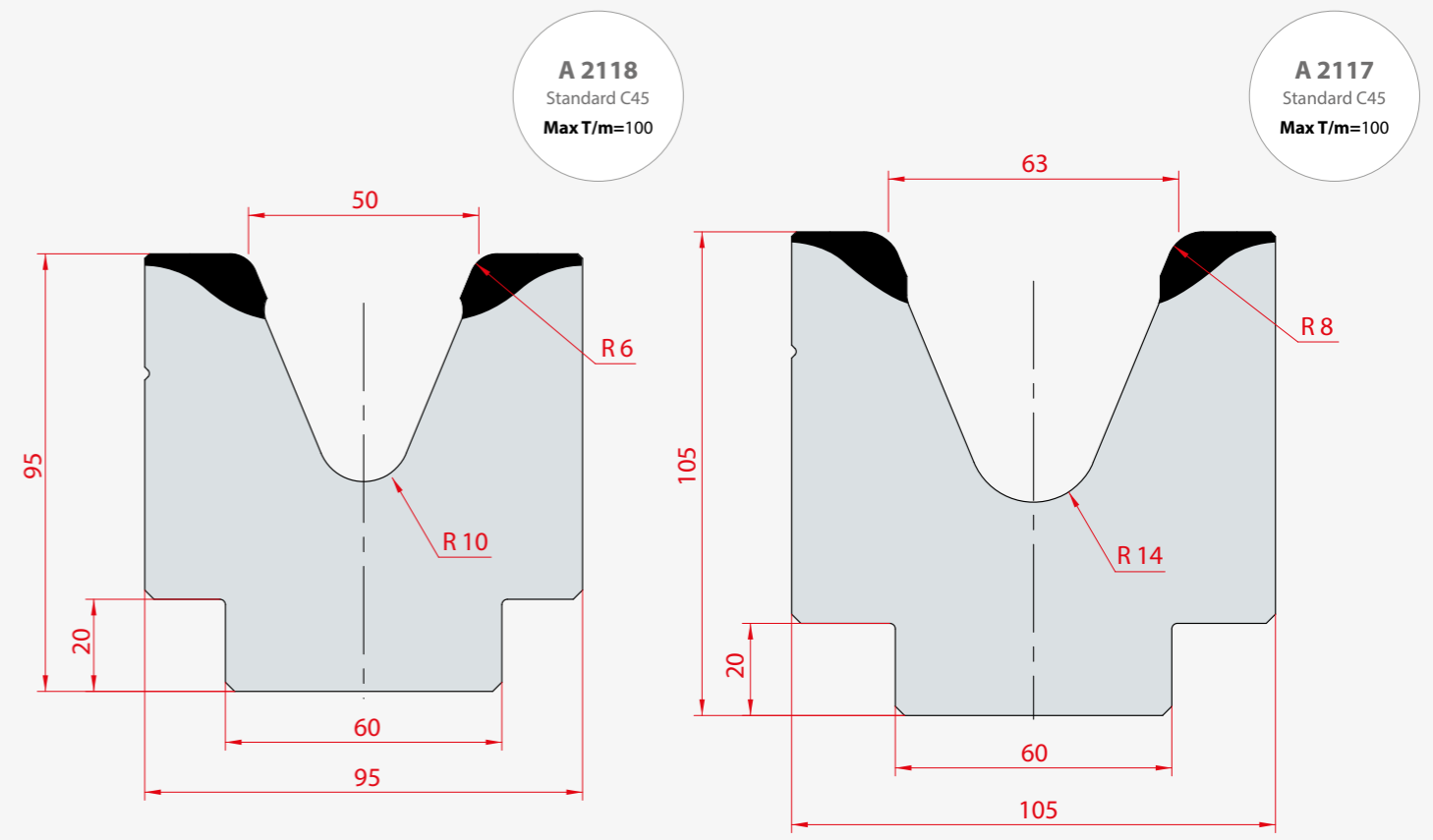
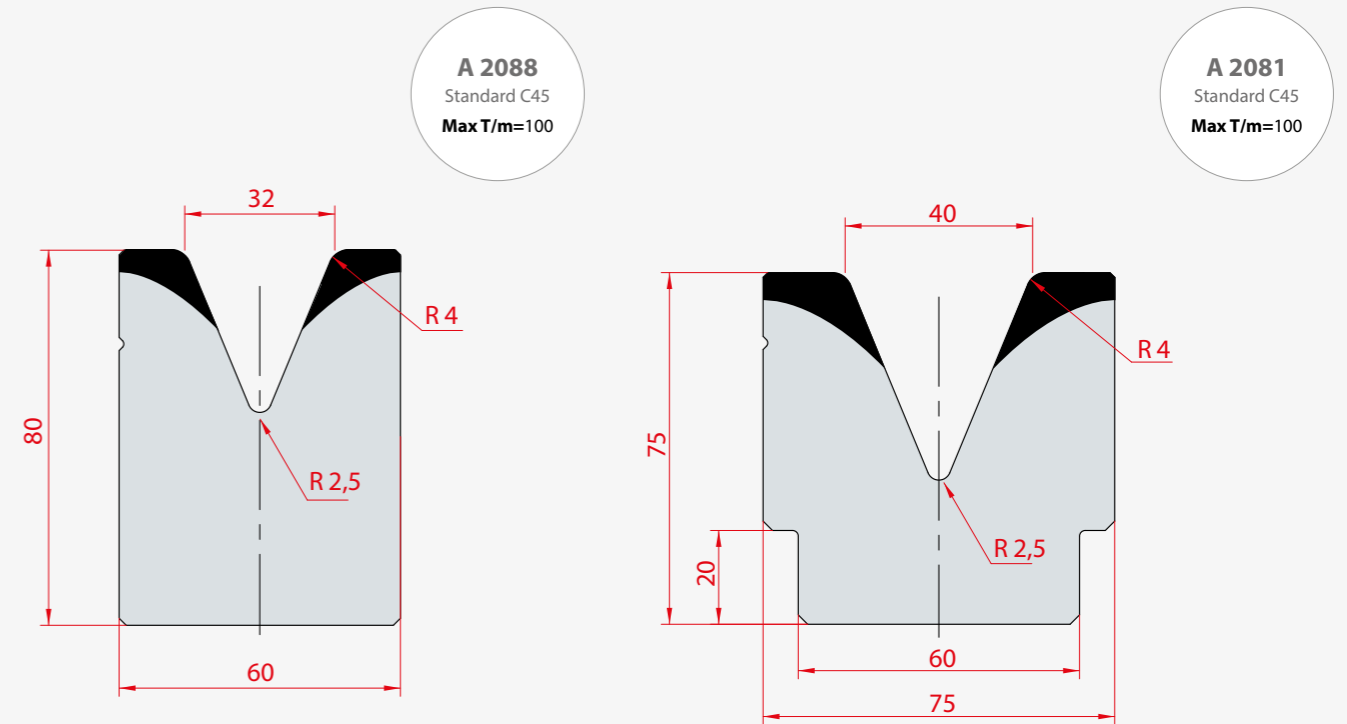
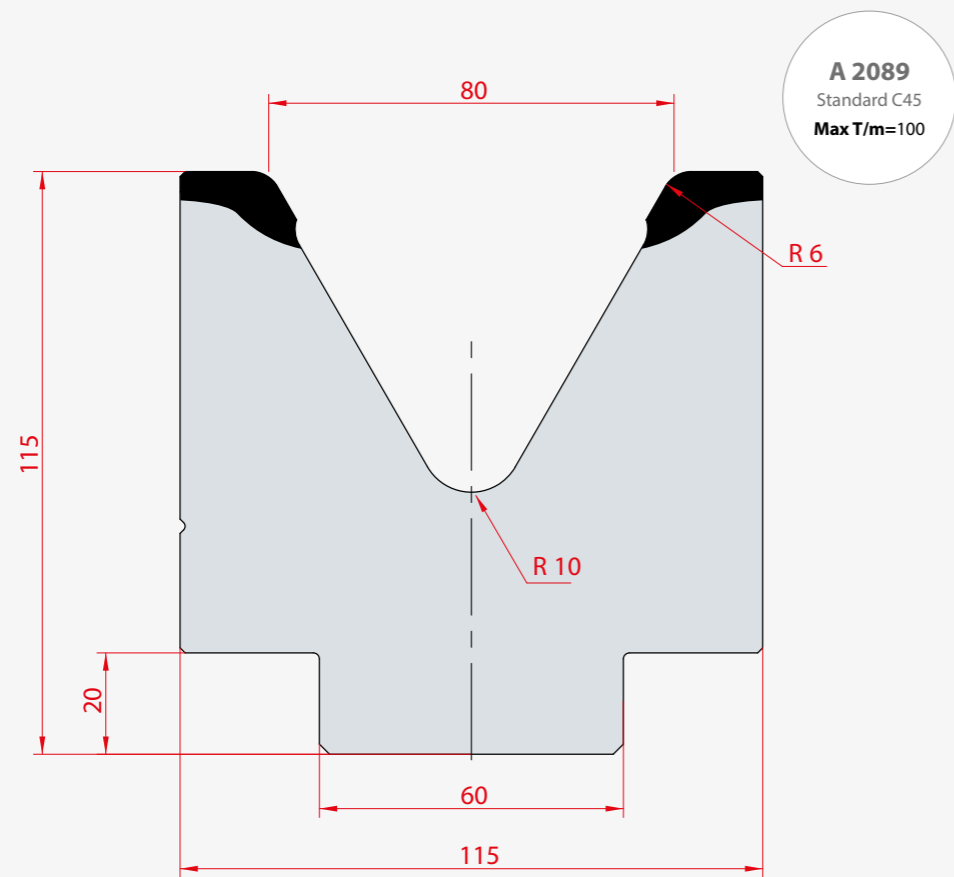
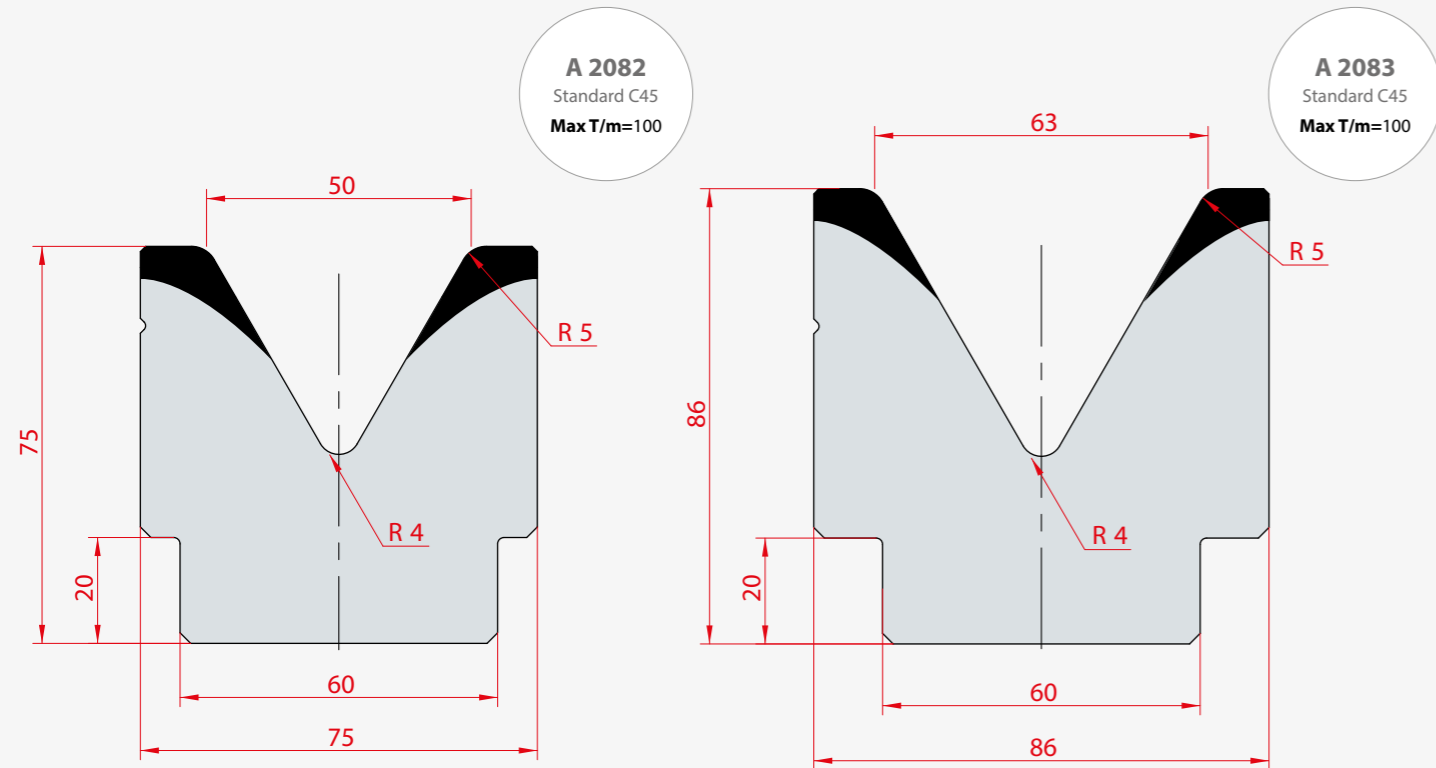

1V DIES 45°

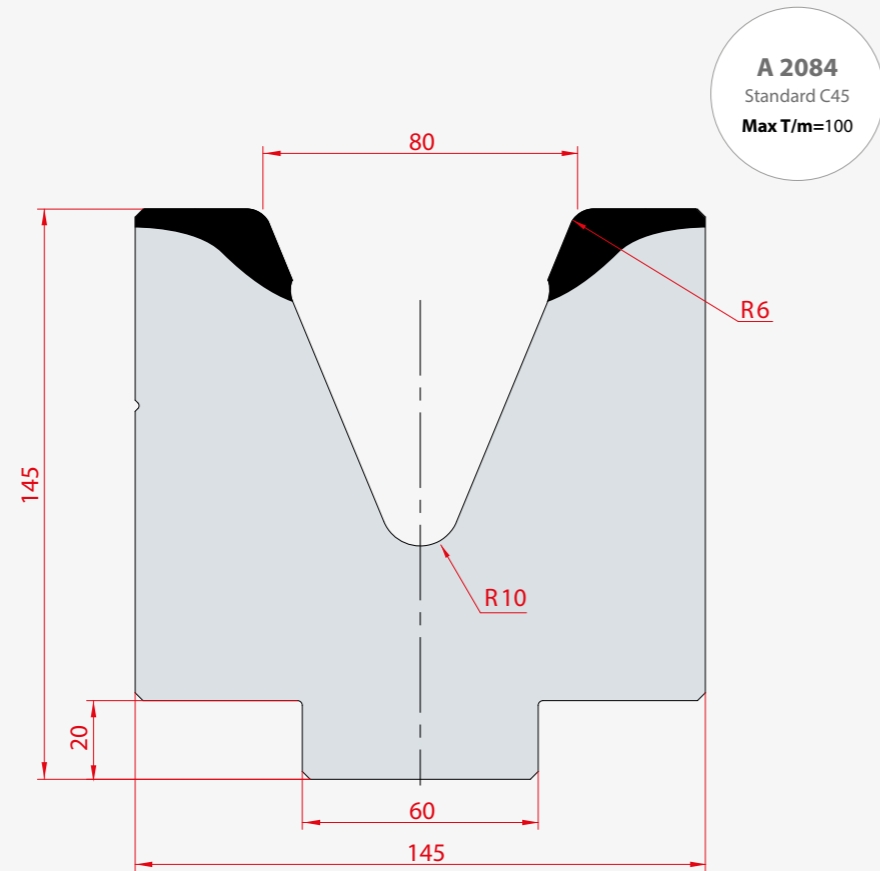

1V DIES 30°

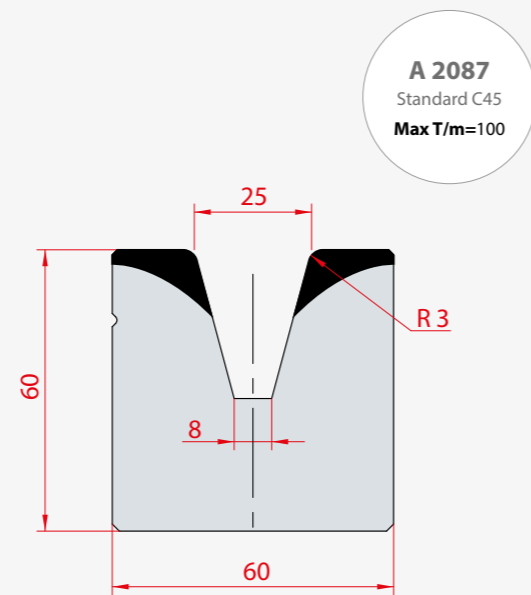
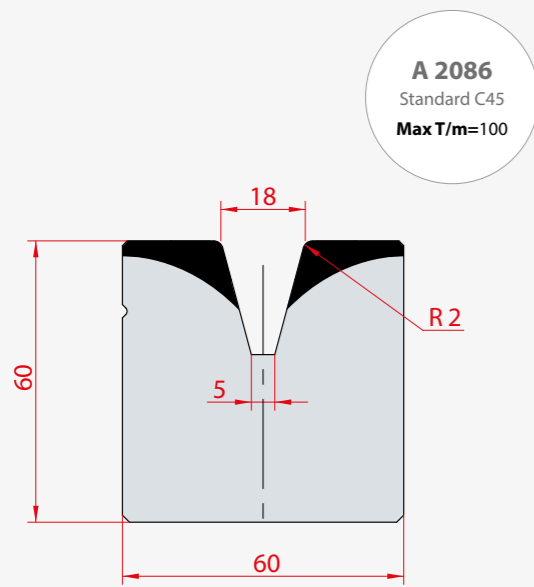

T DIES H80 90°

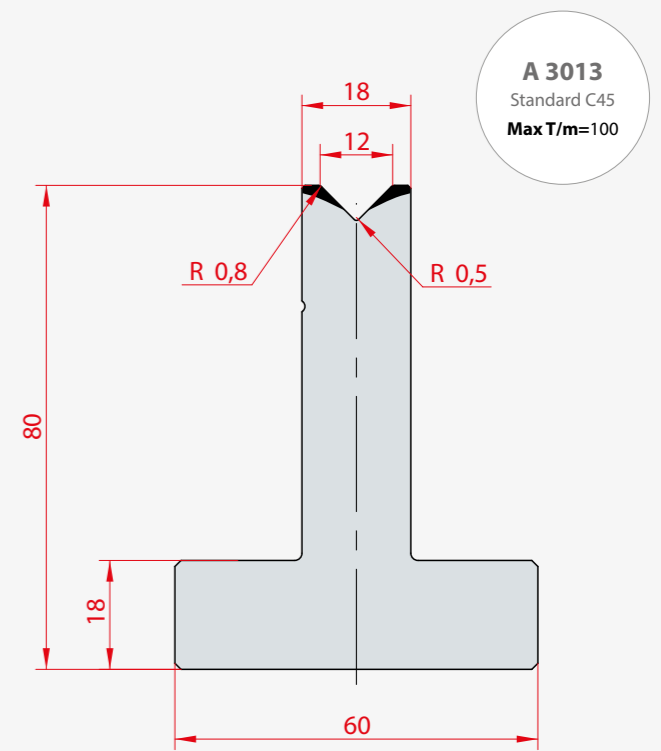
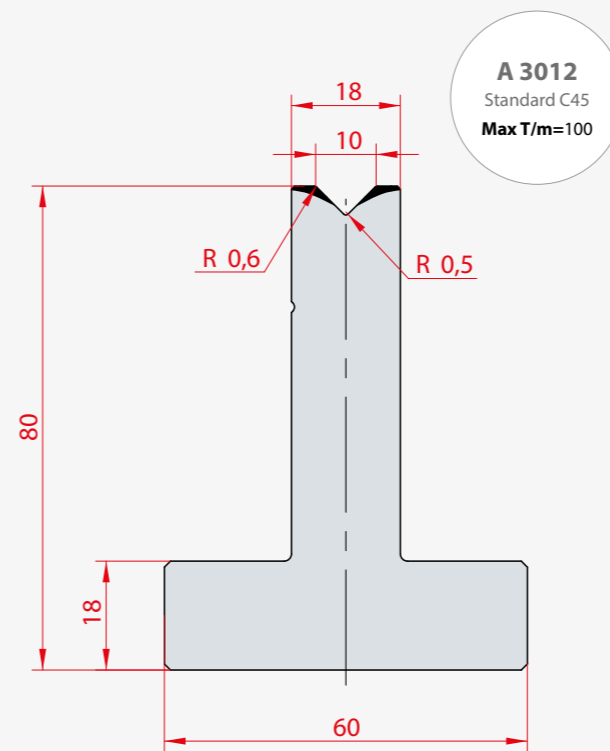
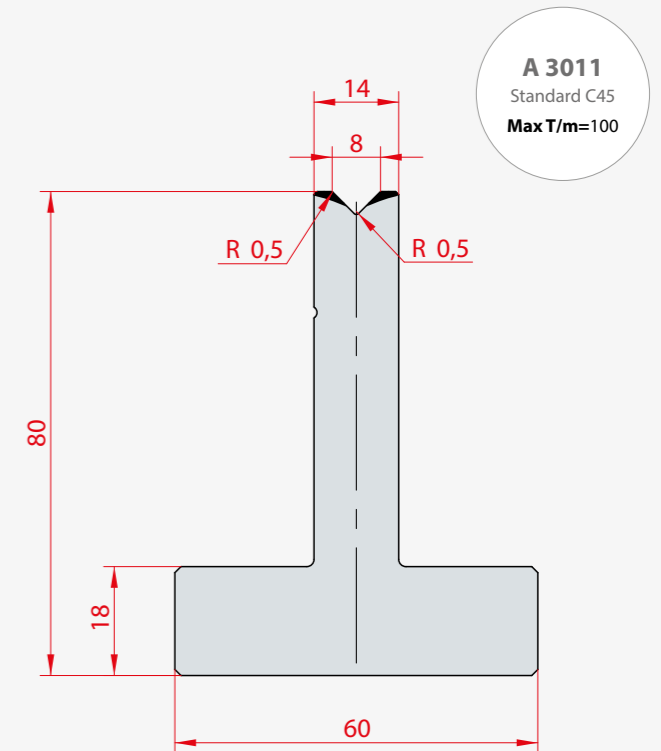
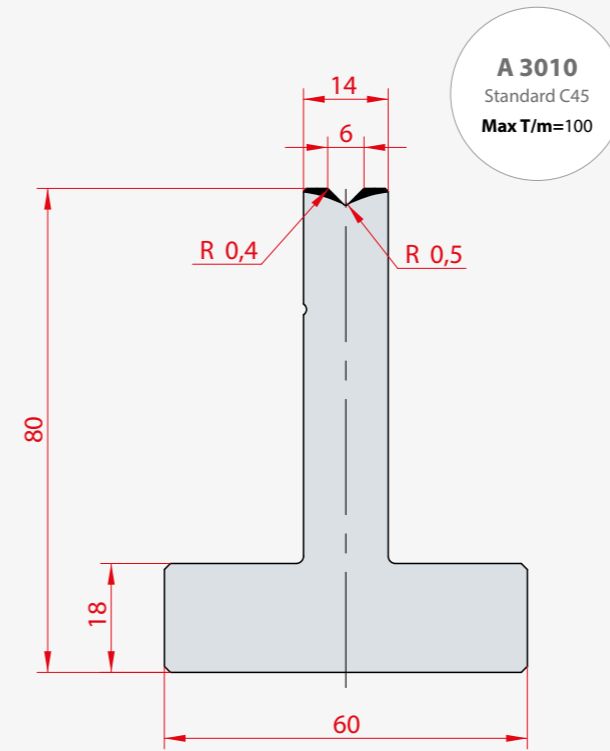

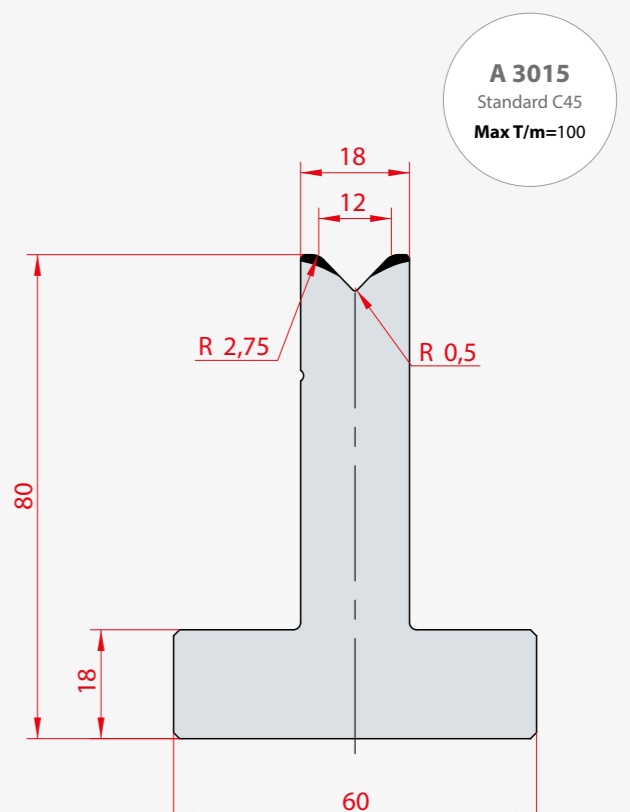
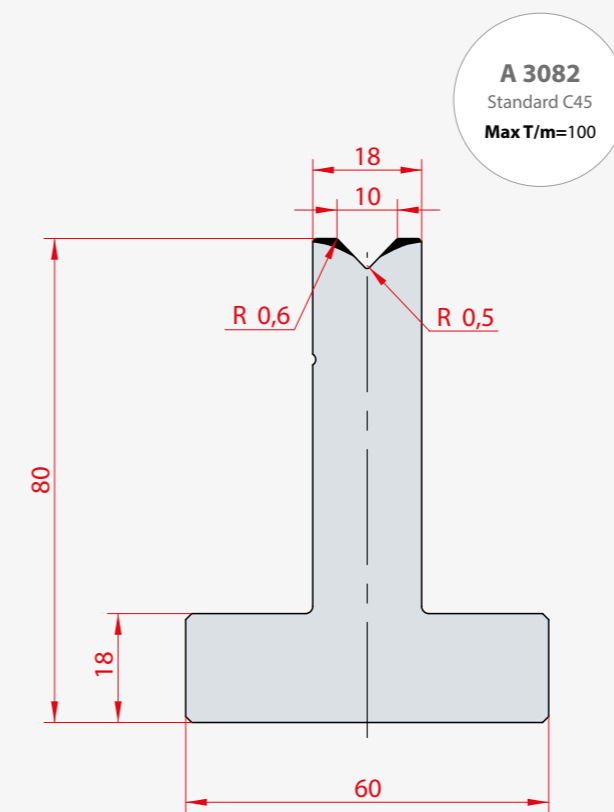
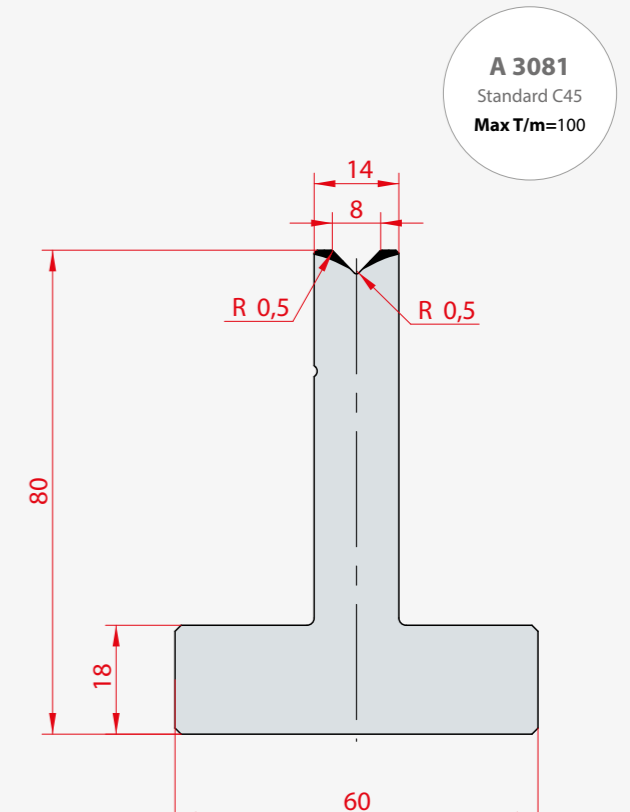
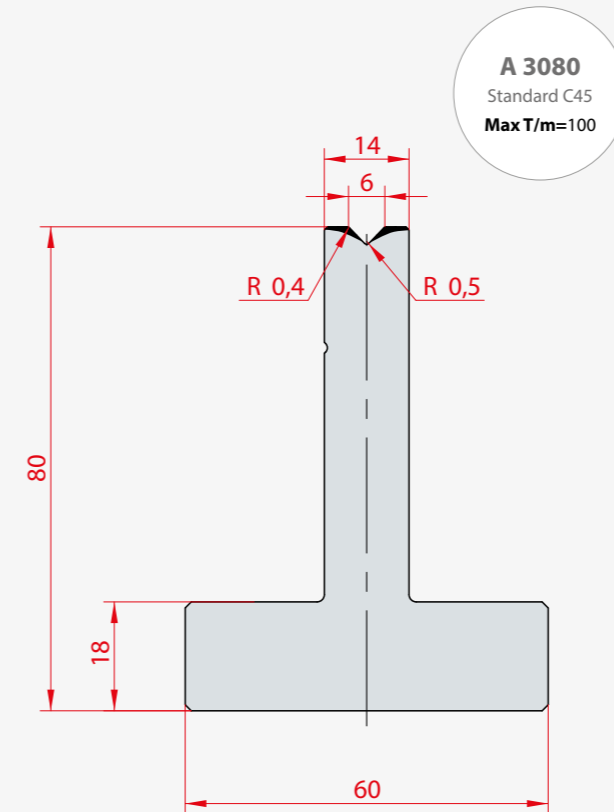
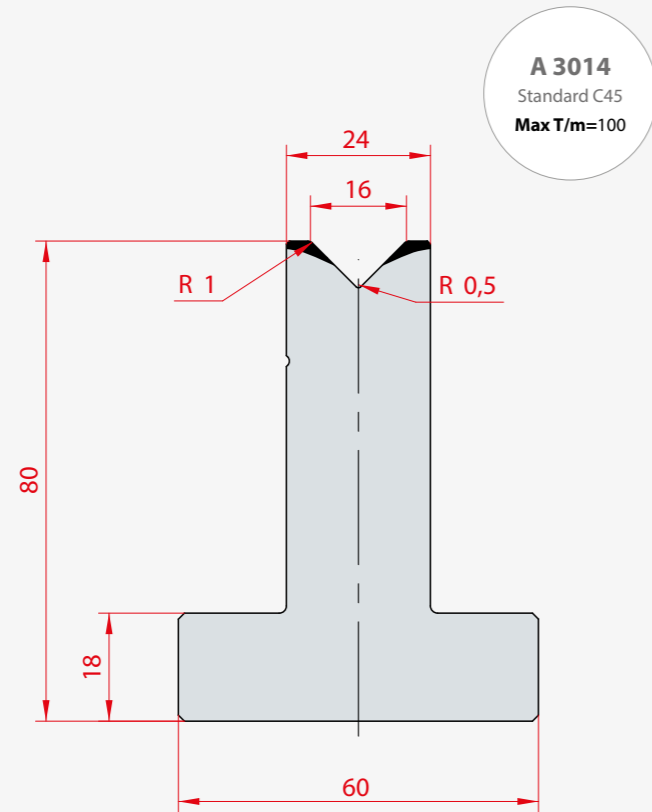

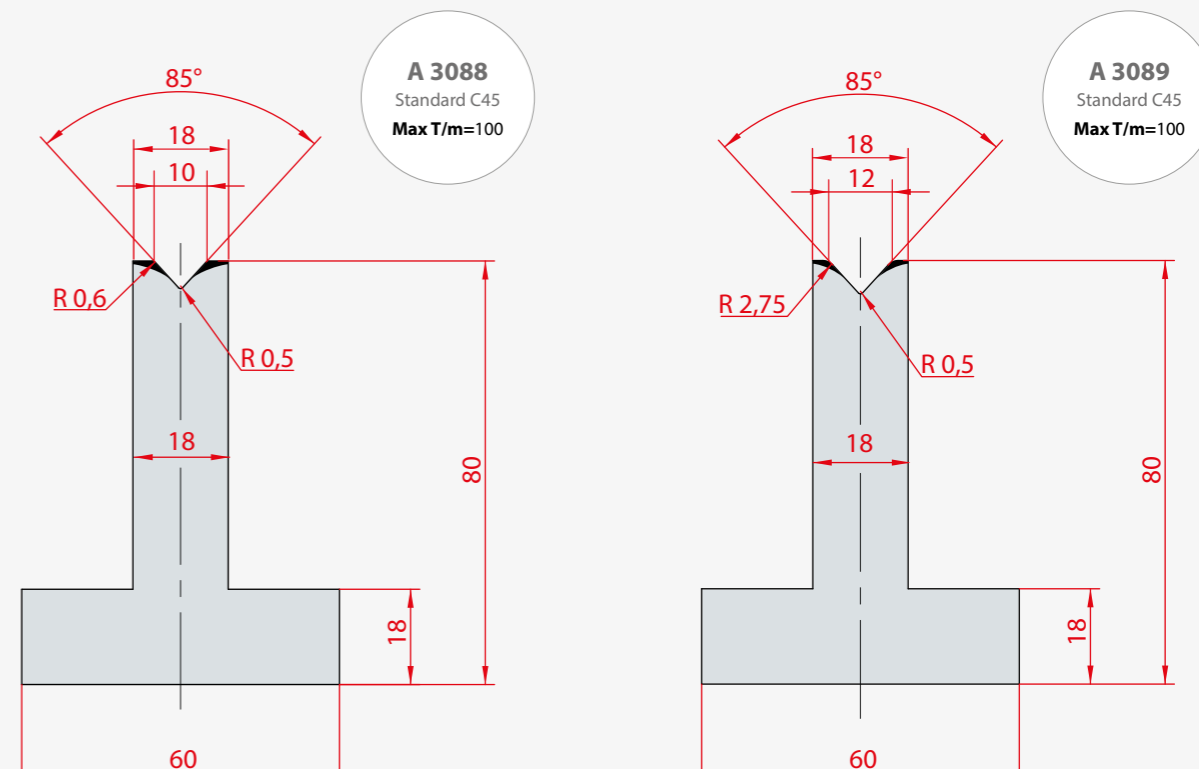
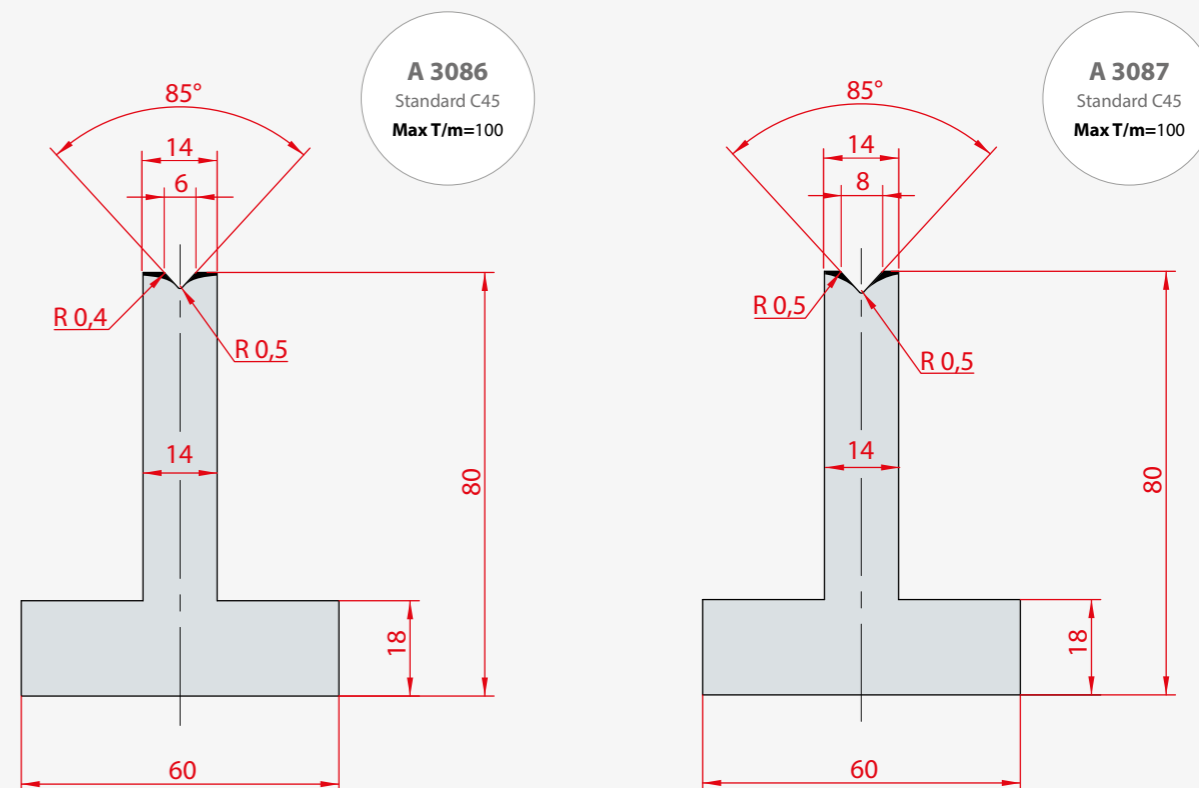
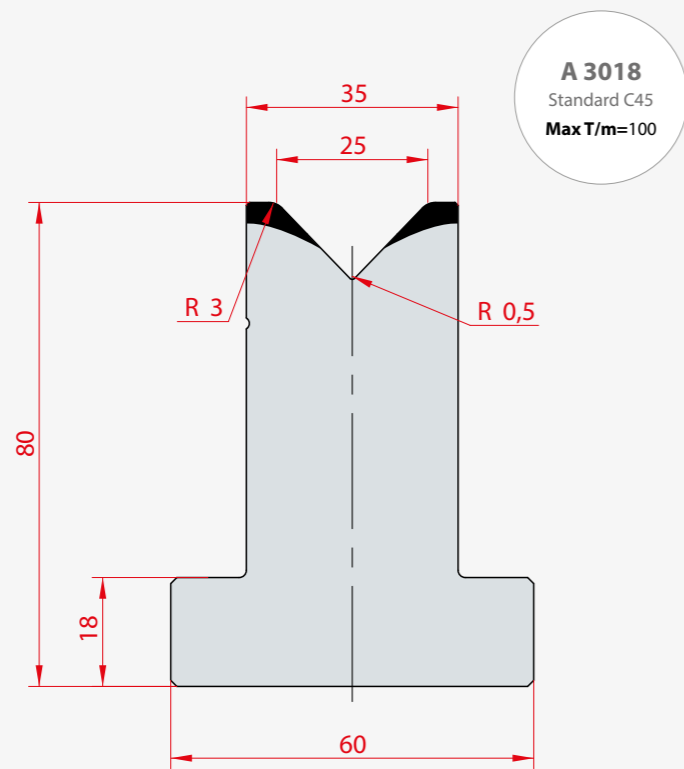
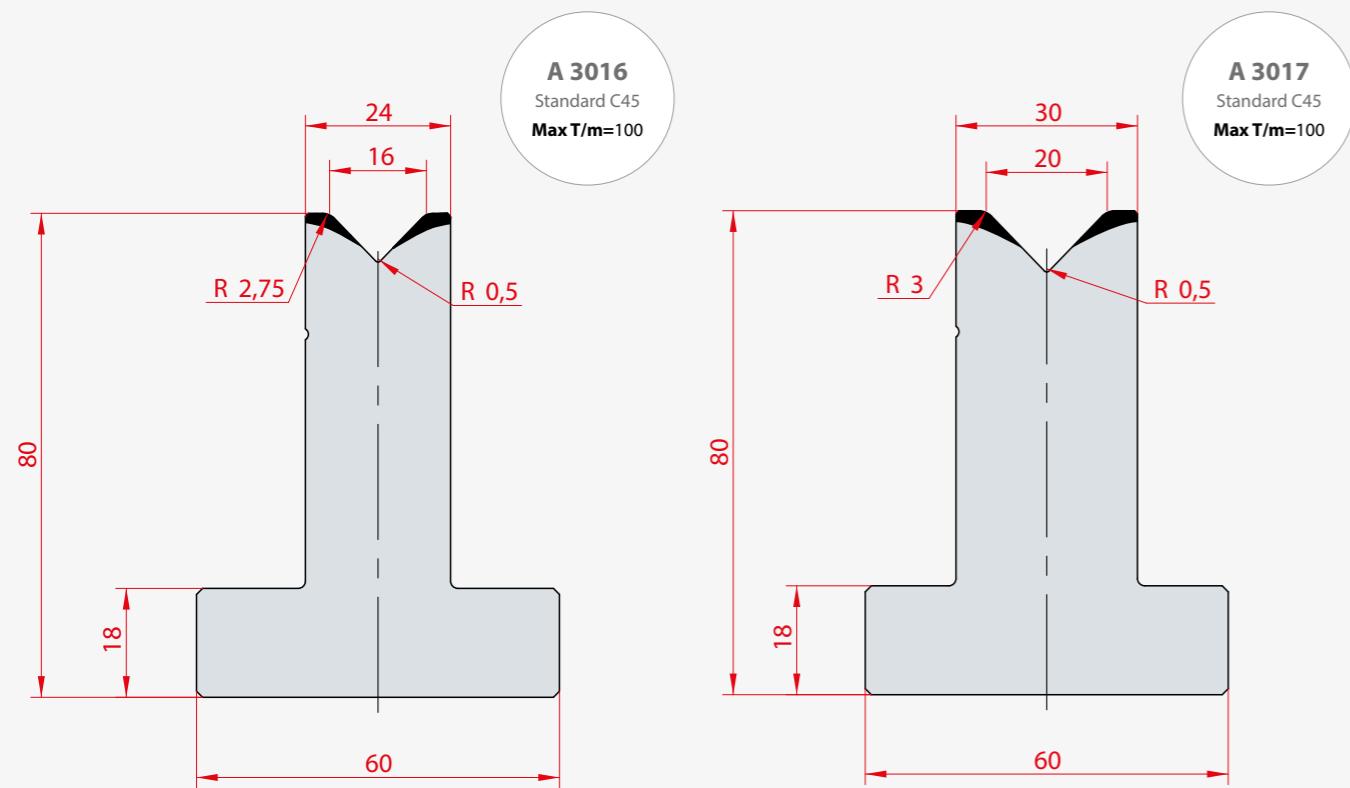

A 3090
Standard C45
Max T/m=100

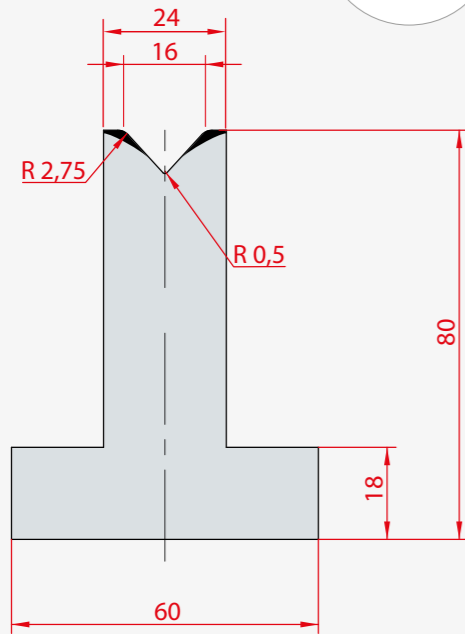

A 3091
Standard C45
Max T/m=100

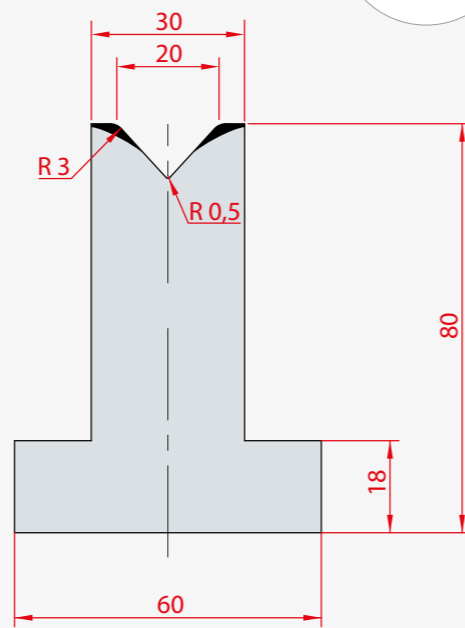

A 3019
Standard C45
Max T/m=60

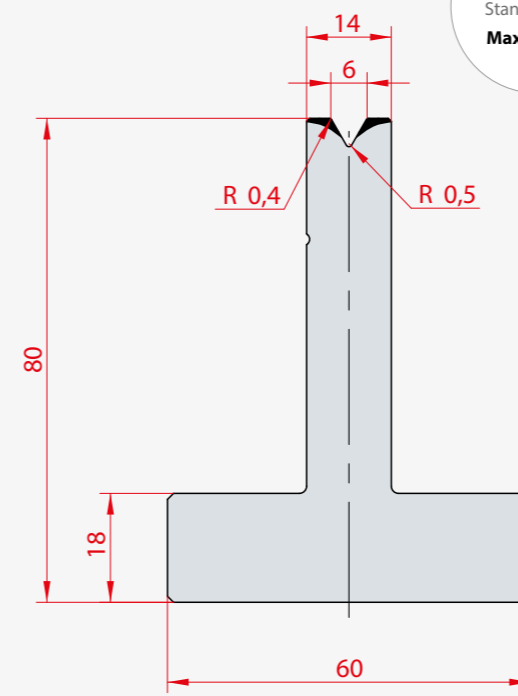

A 3020
Standard C45
Max T/m=60

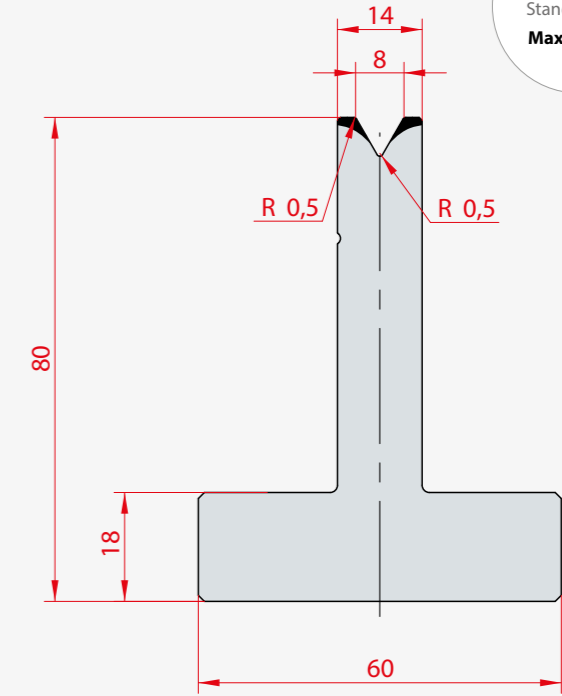

A 3092
Standard C45
Max T/m=100

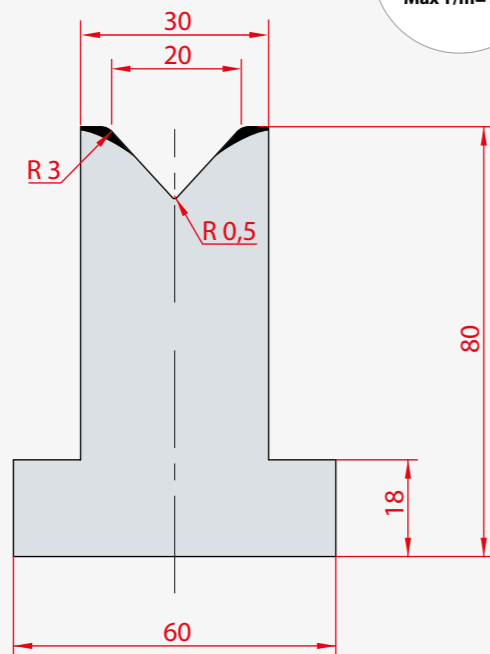

A 3021
Standard C45
Max T/m=60

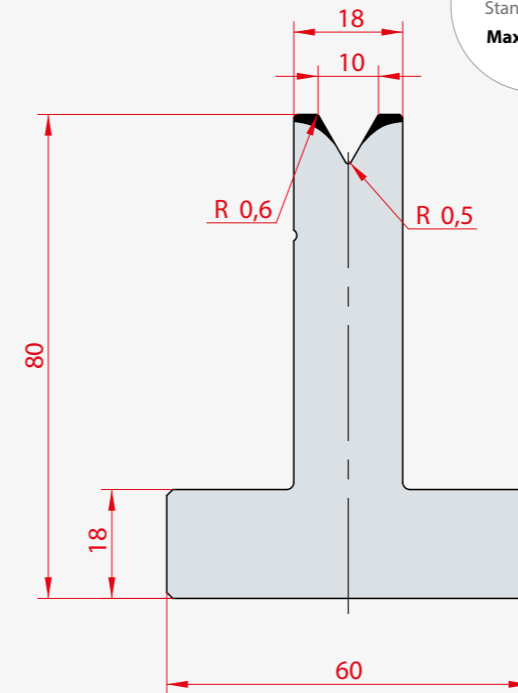

A 3022
Standard C45
Max T/m=75

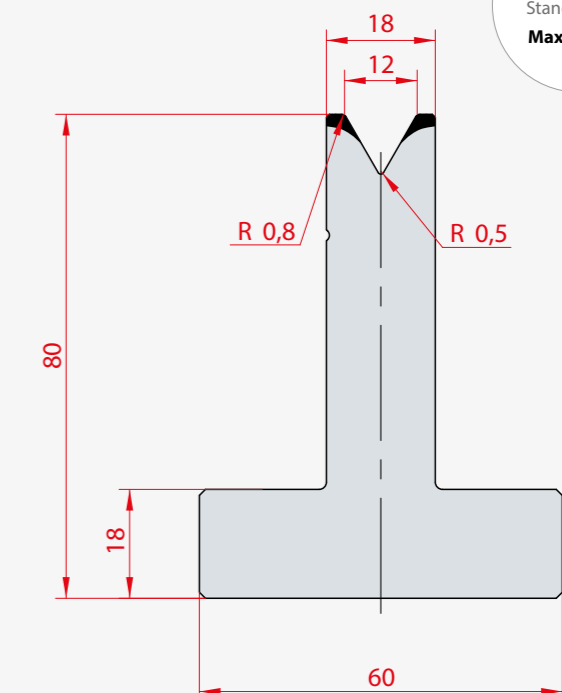

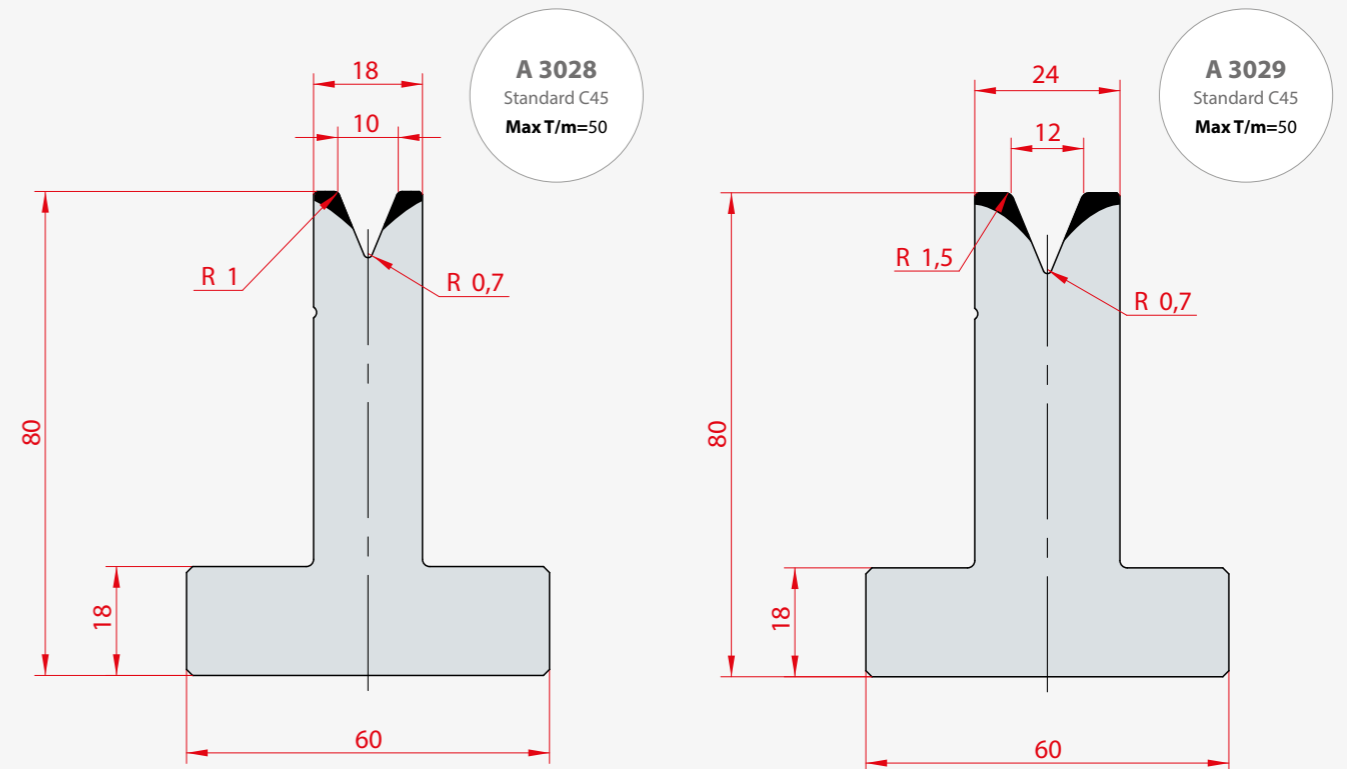
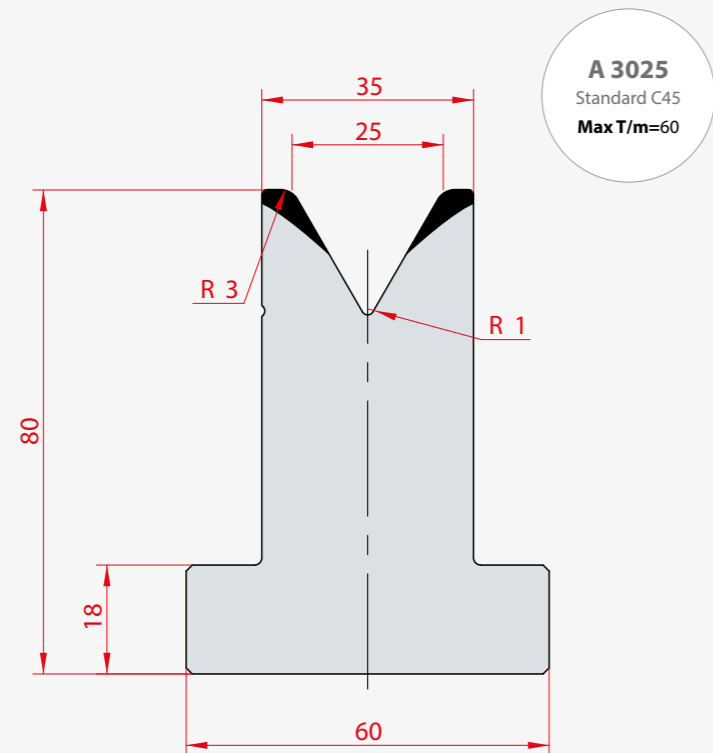
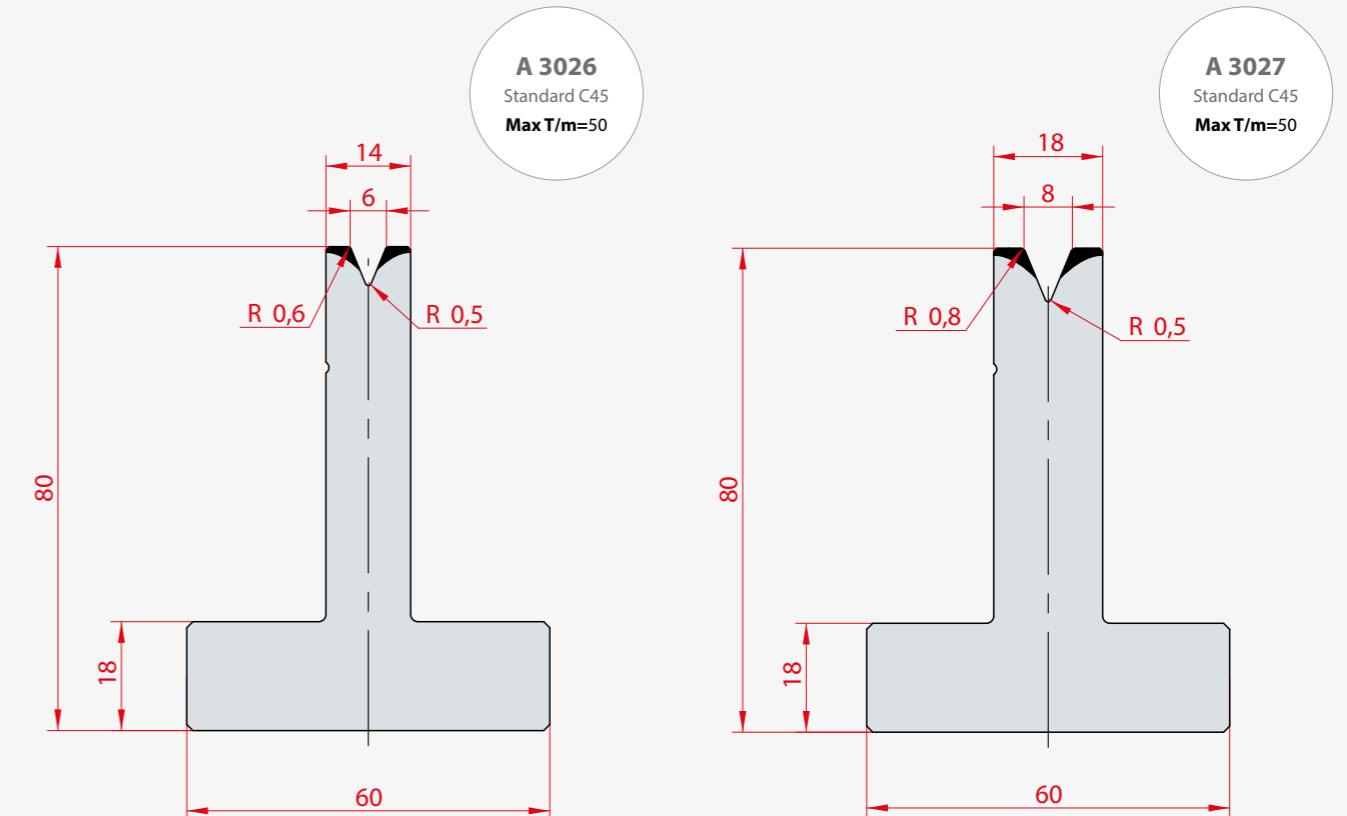
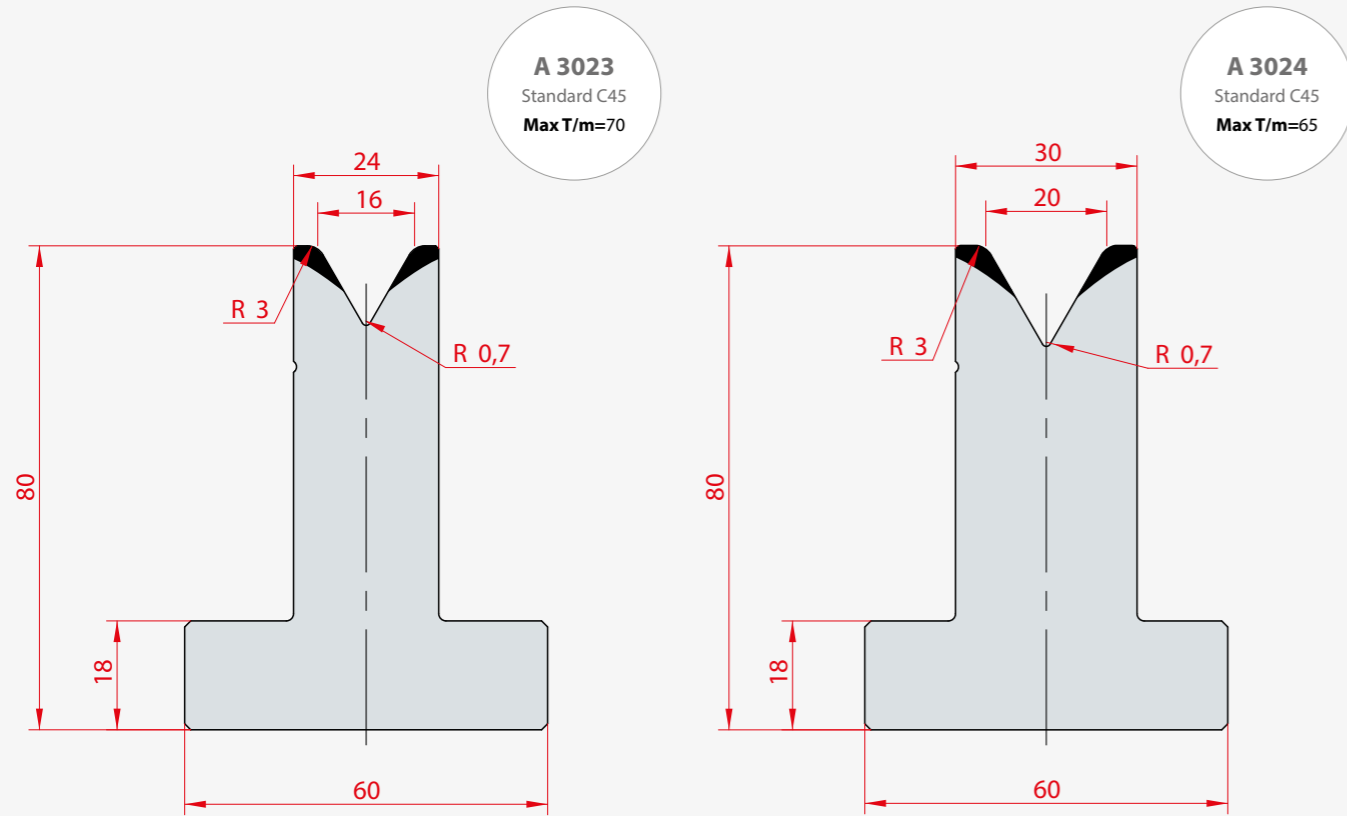

T DIES H80 45°

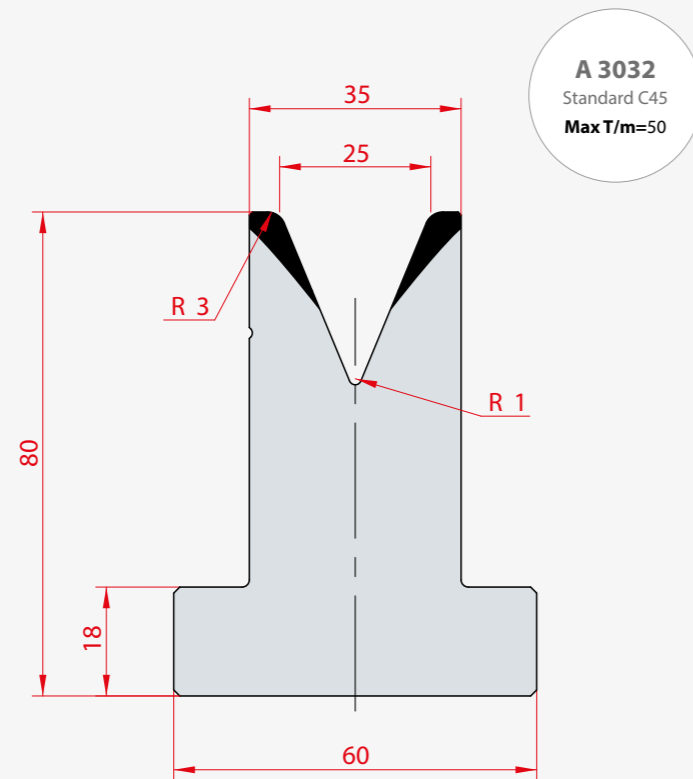
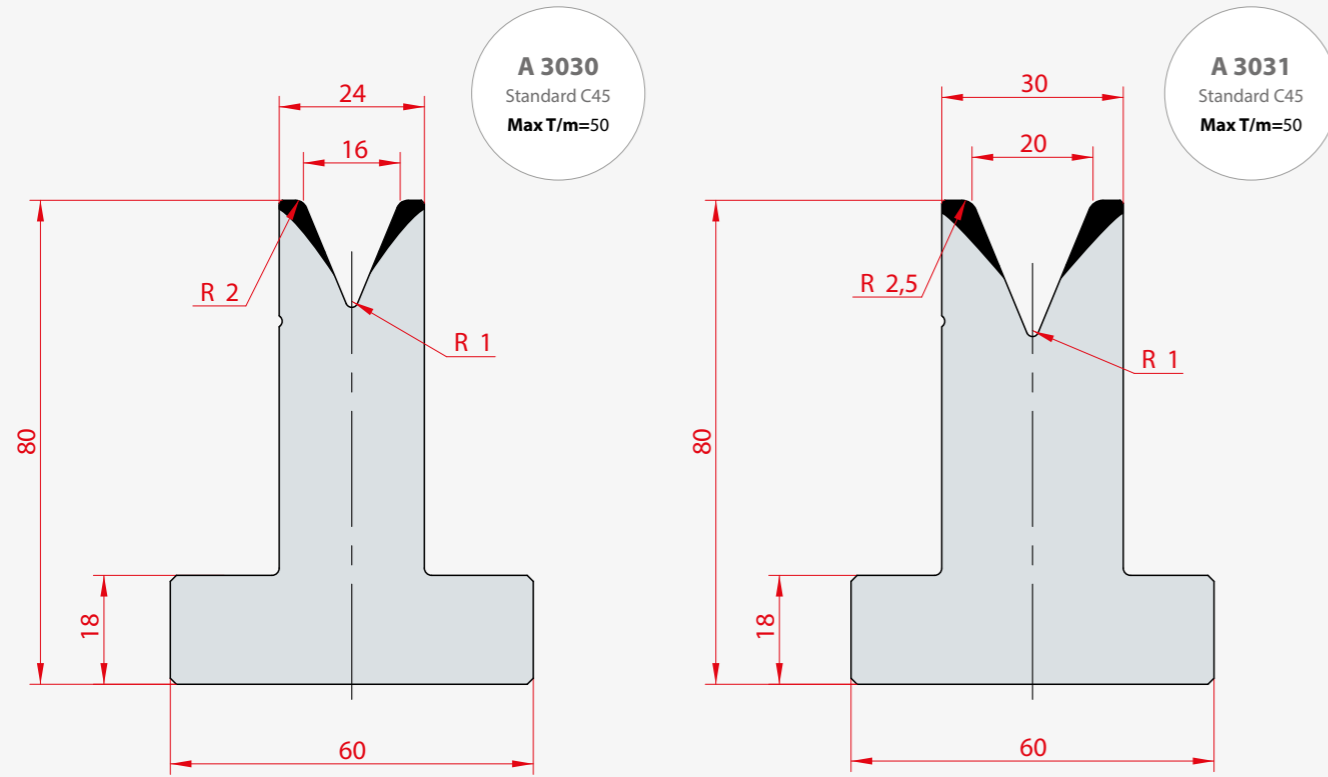

T DIES H80 30°

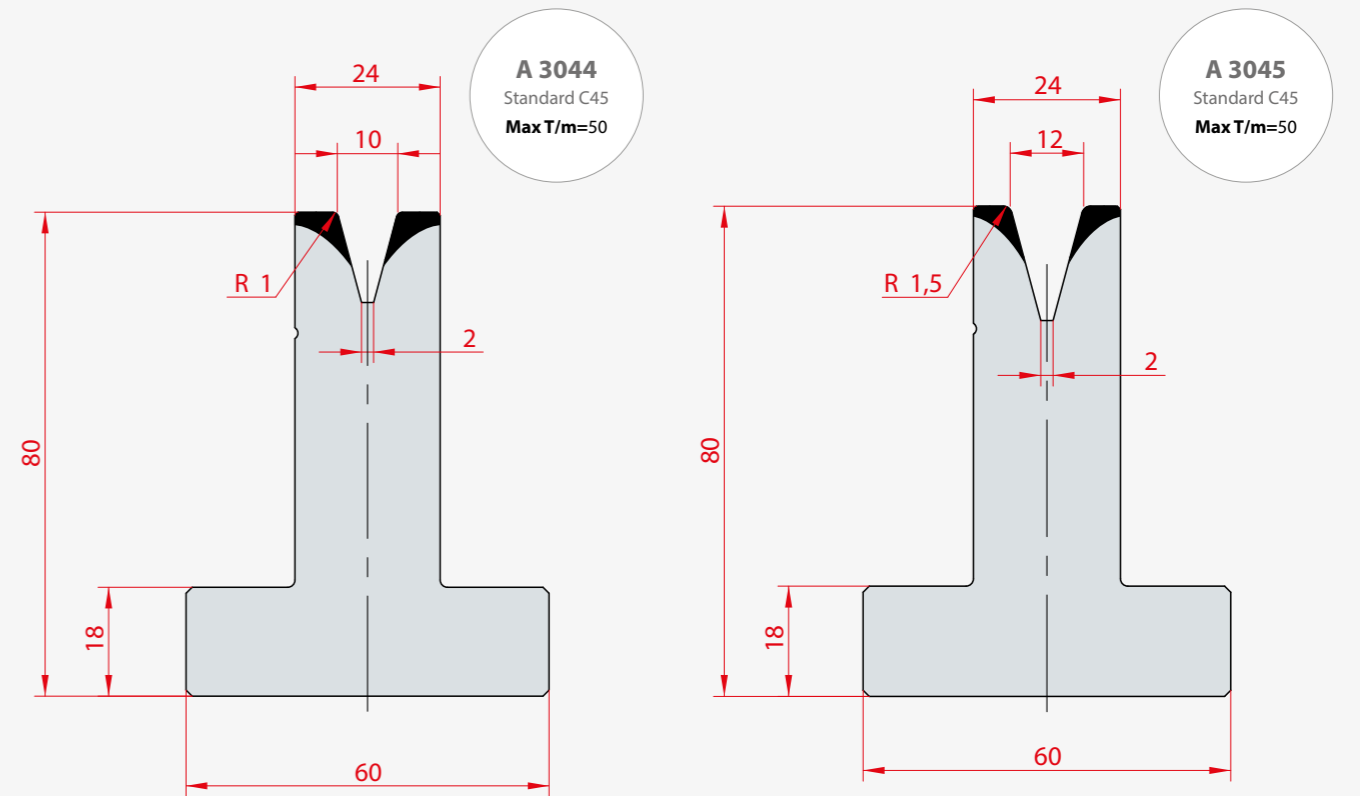
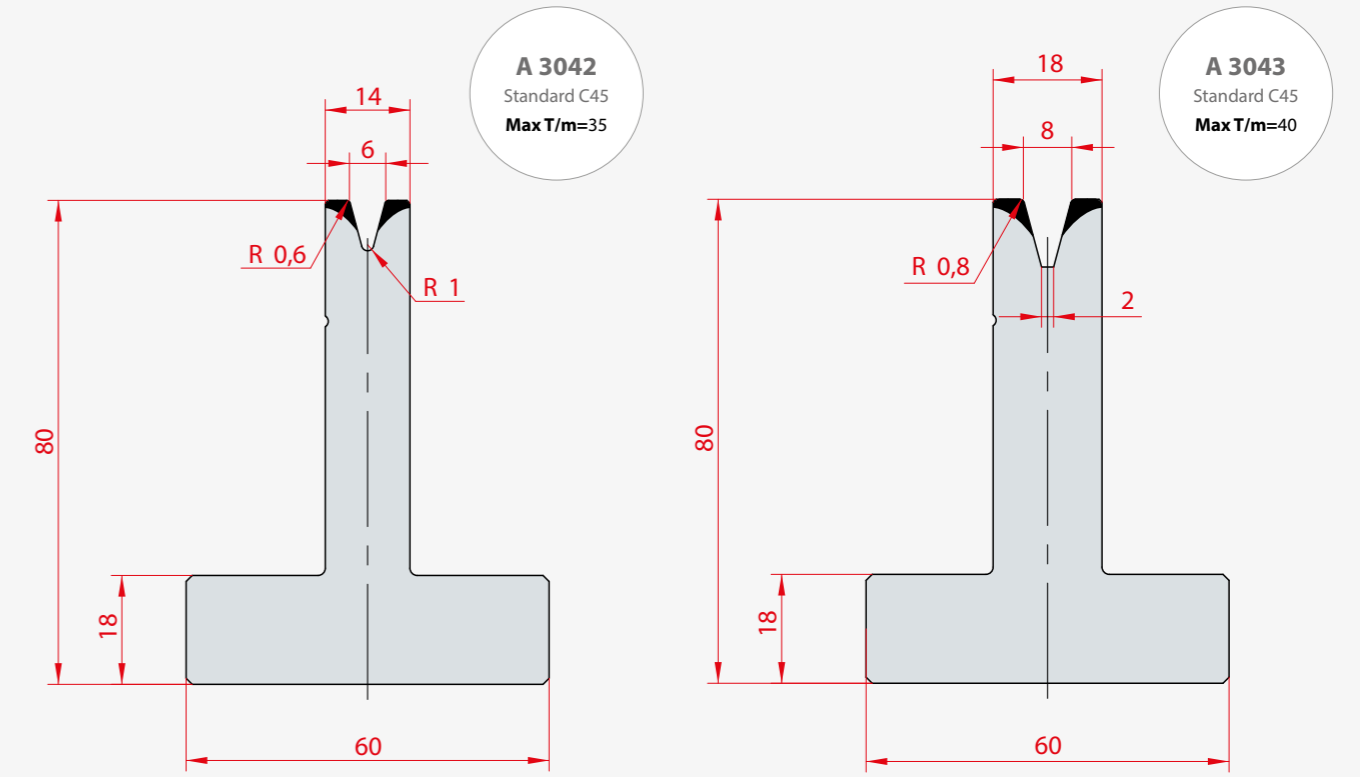

T DIES H80 30°

A 3046
Standard C45
Max T/m=50

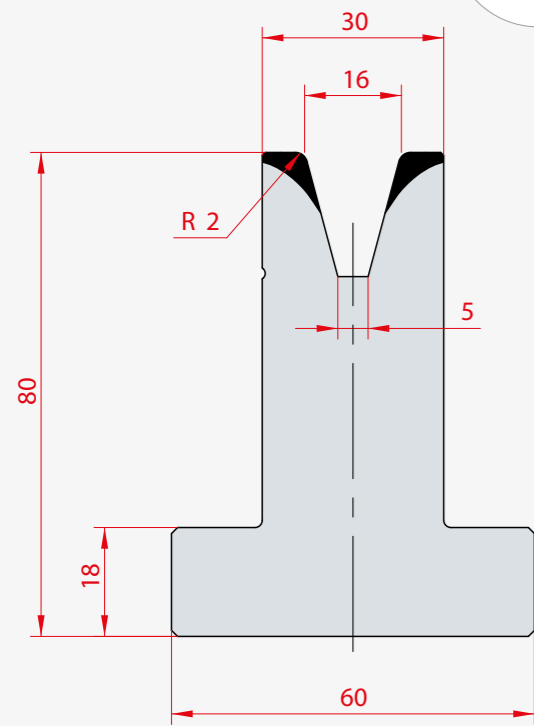

A 3047
Standard C45
Max T/m=55

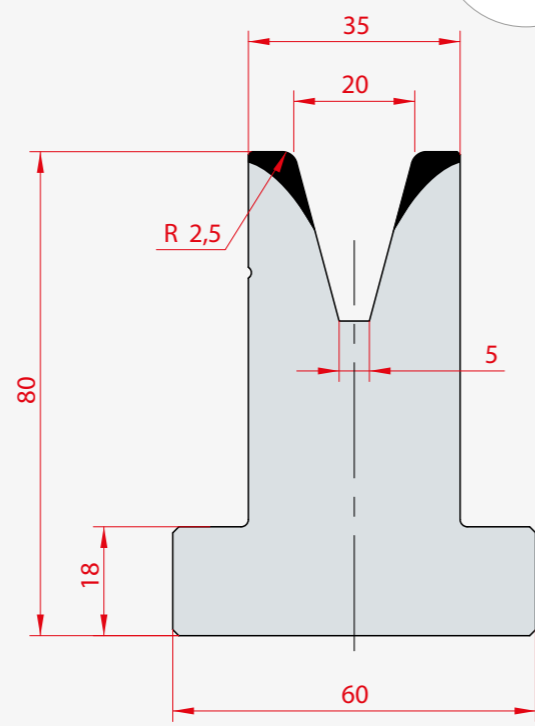

A 3048
Standard C45
Max T/m=55

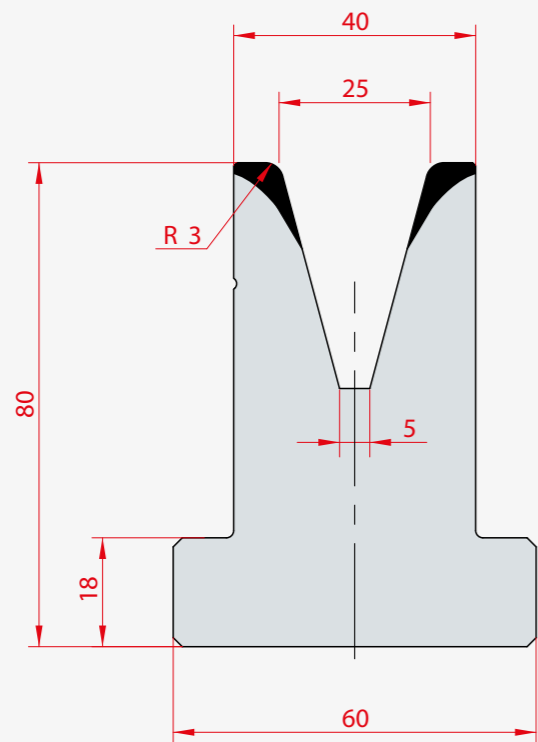

T DIES H120 90°

A 3050
Standard C45
Max T/m=100

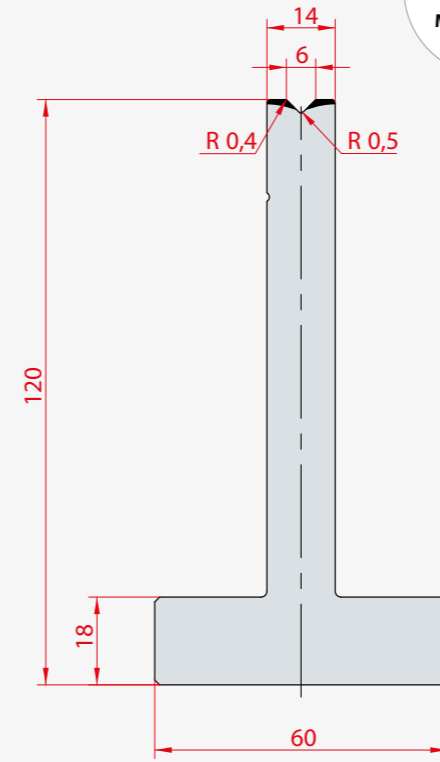

A 3051
Standard C45
Max T/m=100

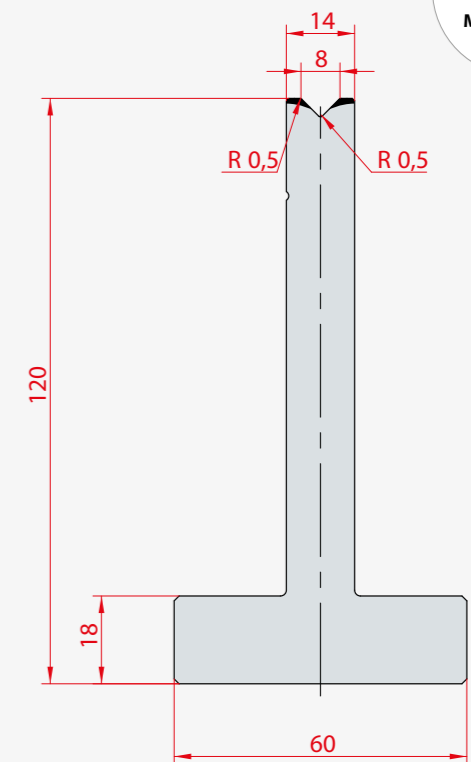

A 3052
Standard C45
Max T/m=100

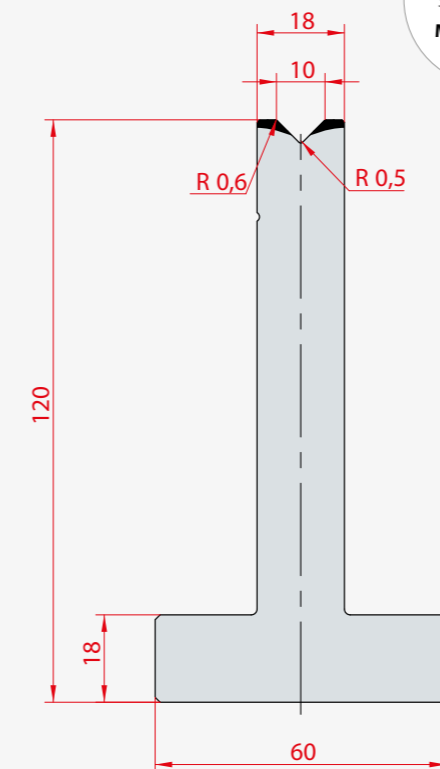

A 3053
Standard C45
Max T/m=100

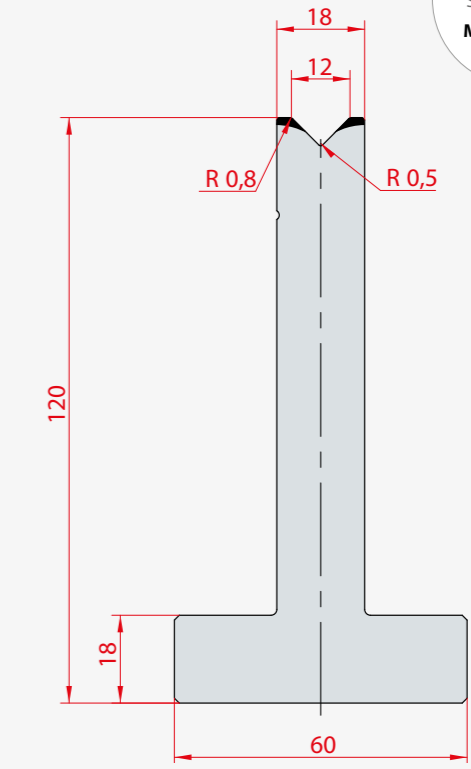

T DIES H120 90°

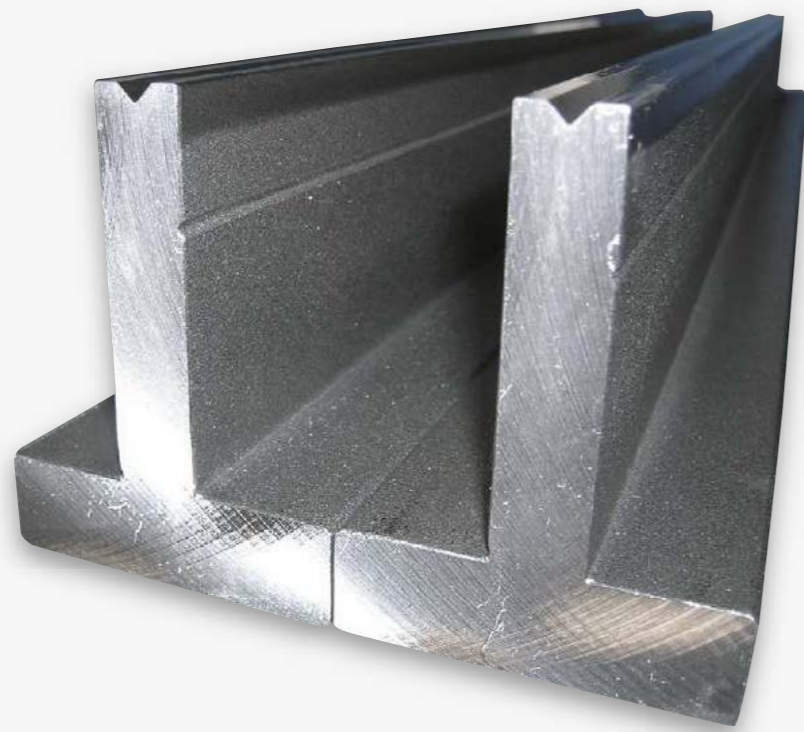
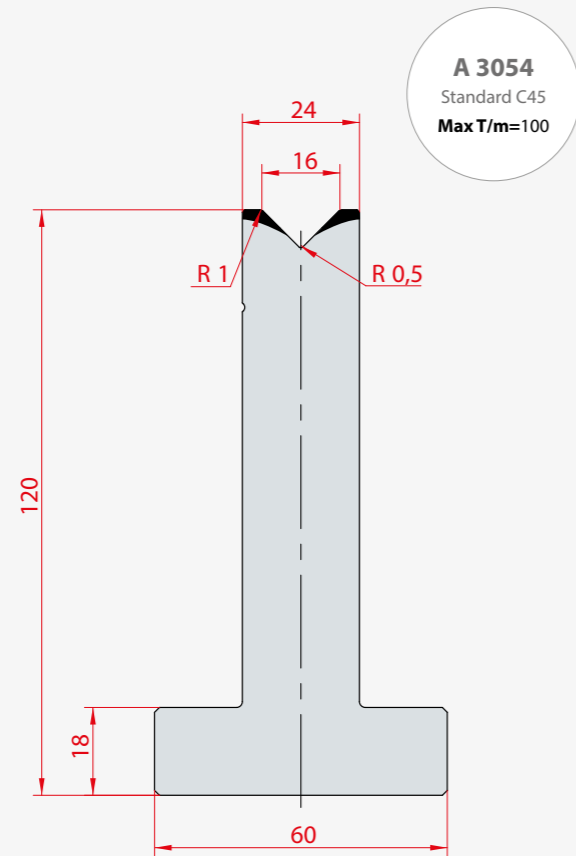

T DIES H120 88°

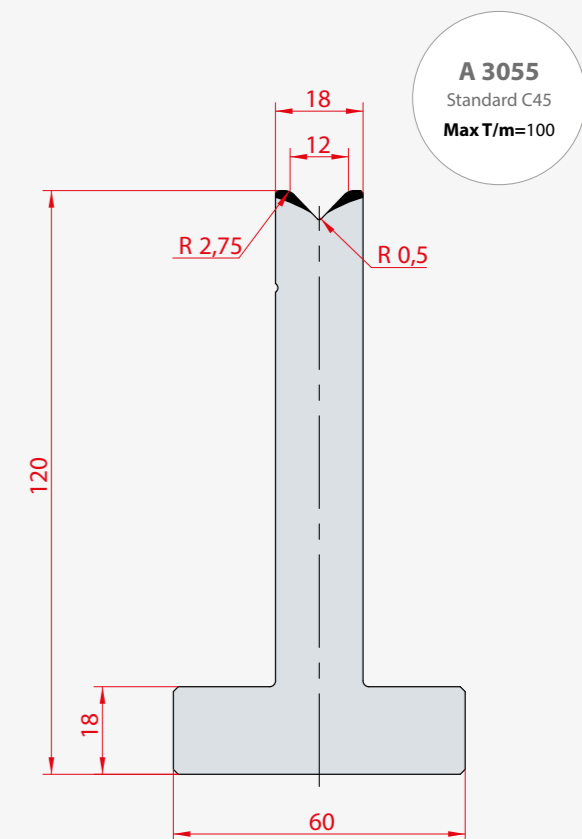
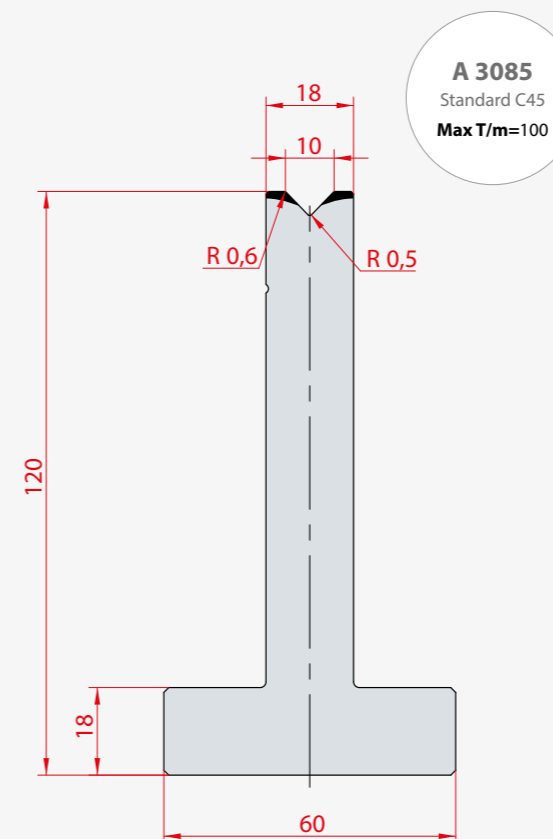
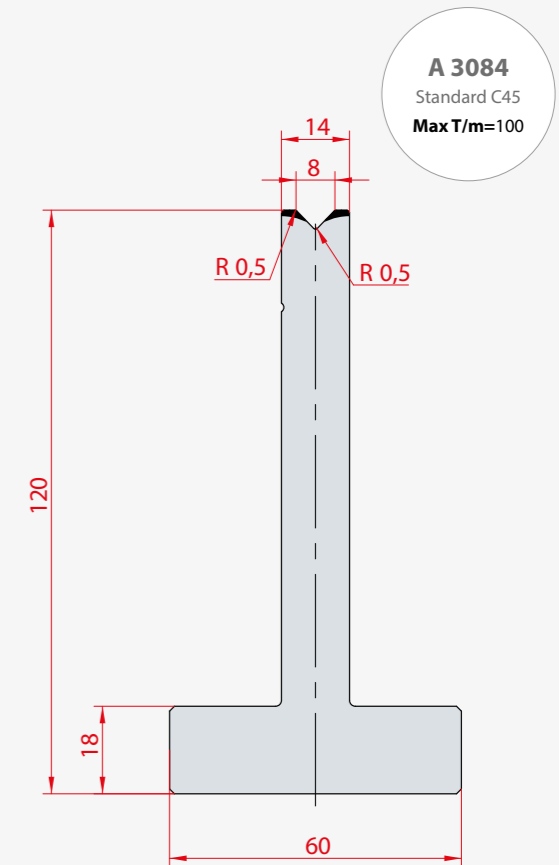
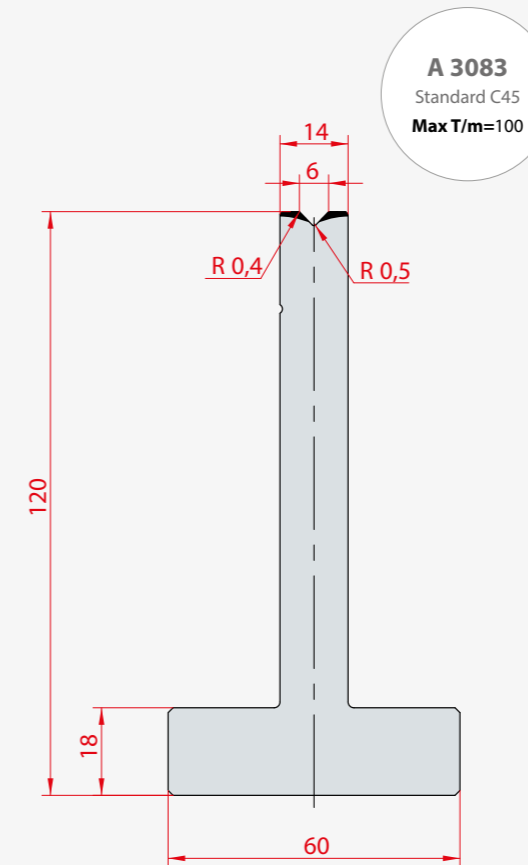

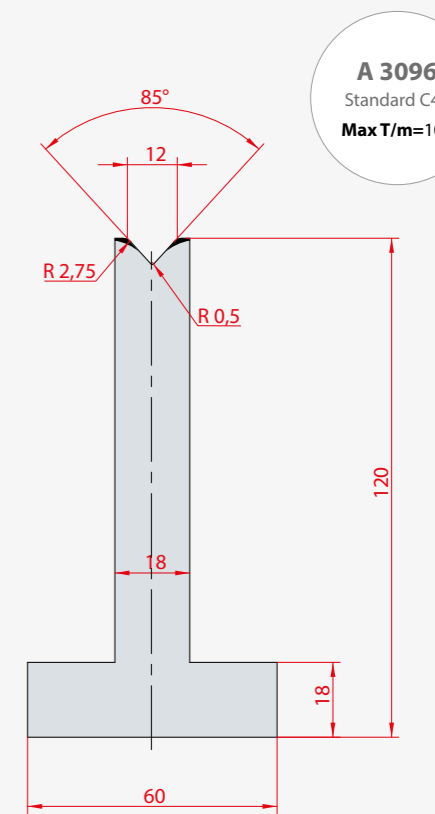
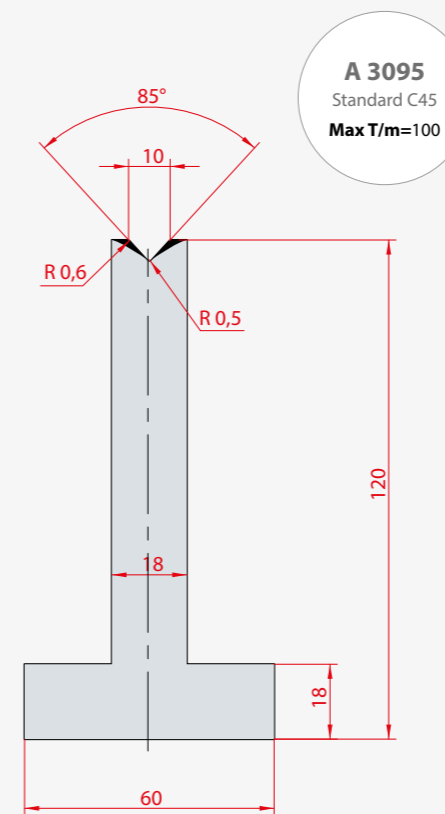
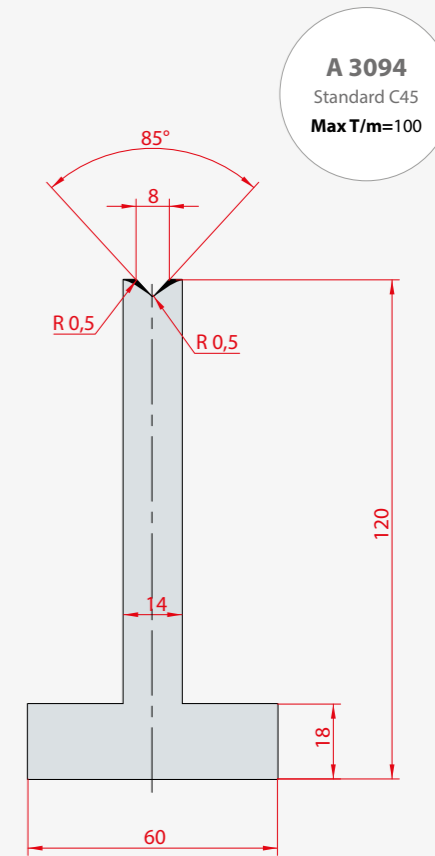
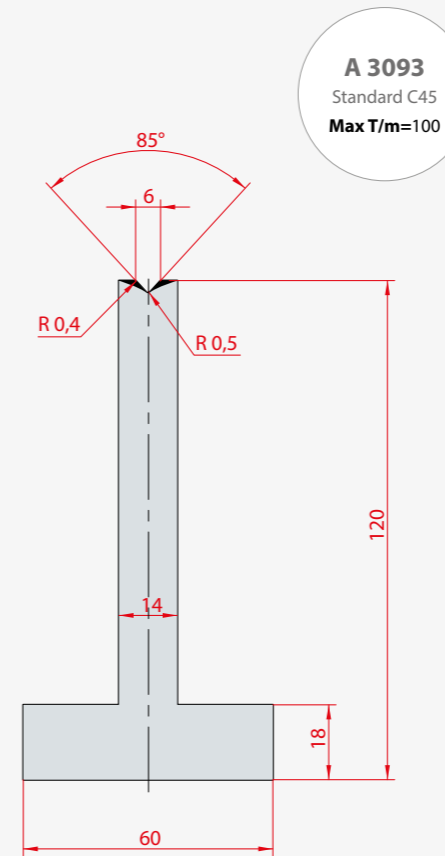
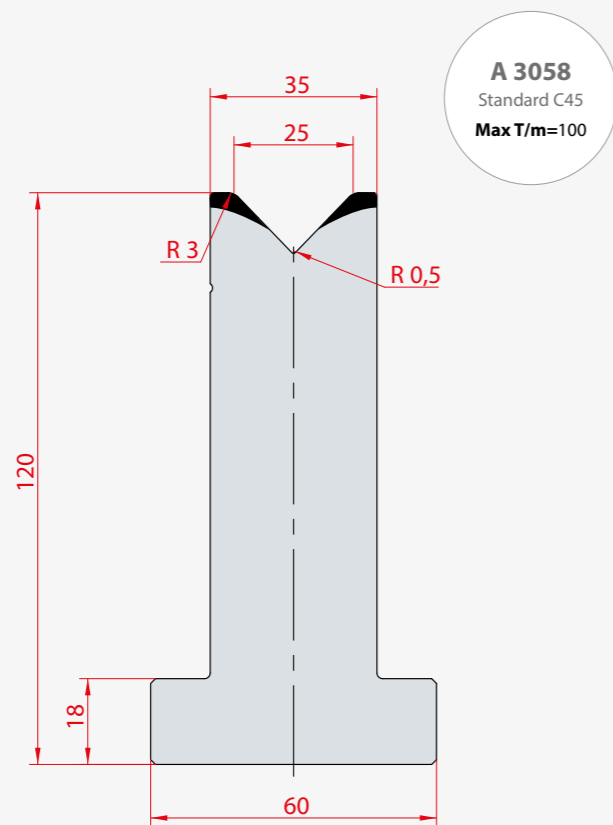
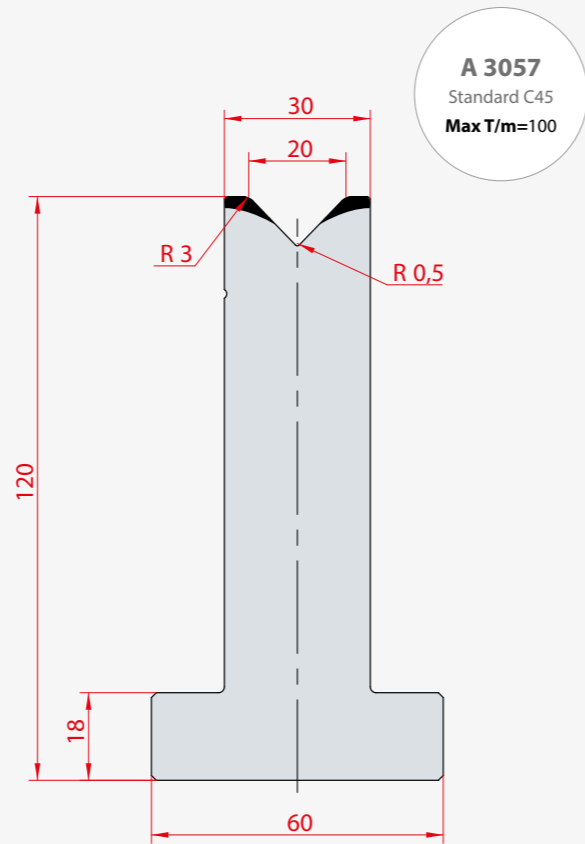
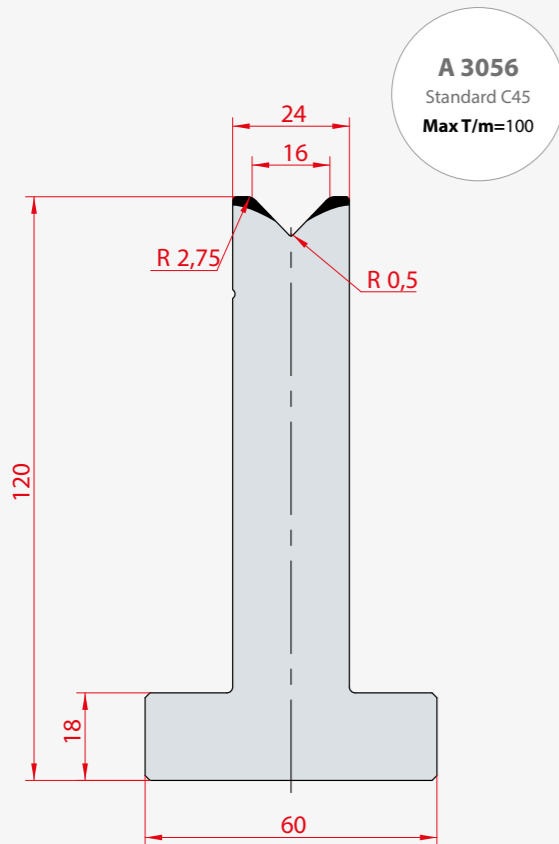

T DIES H120 85°

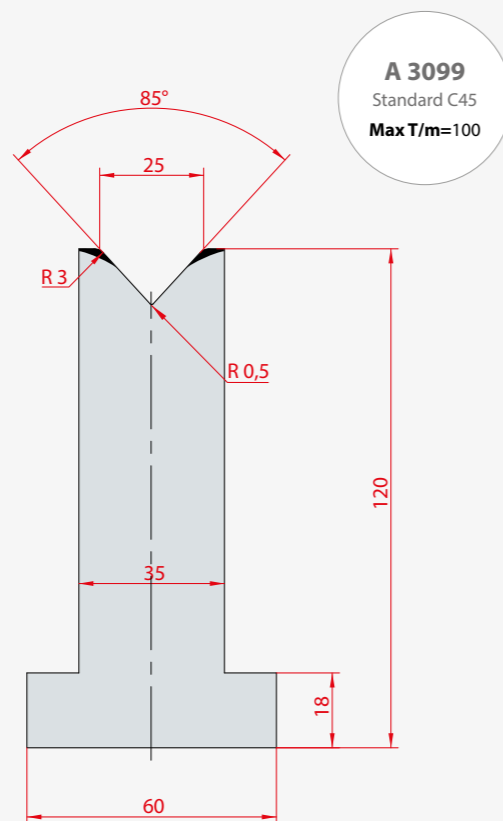
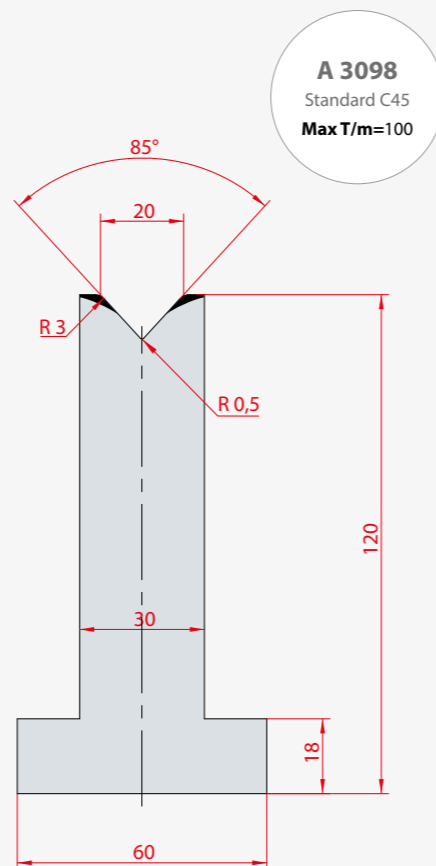
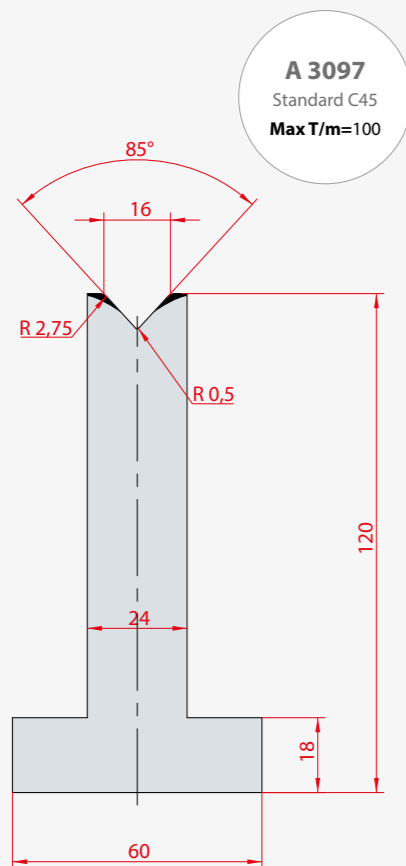

T DIES H120 60°

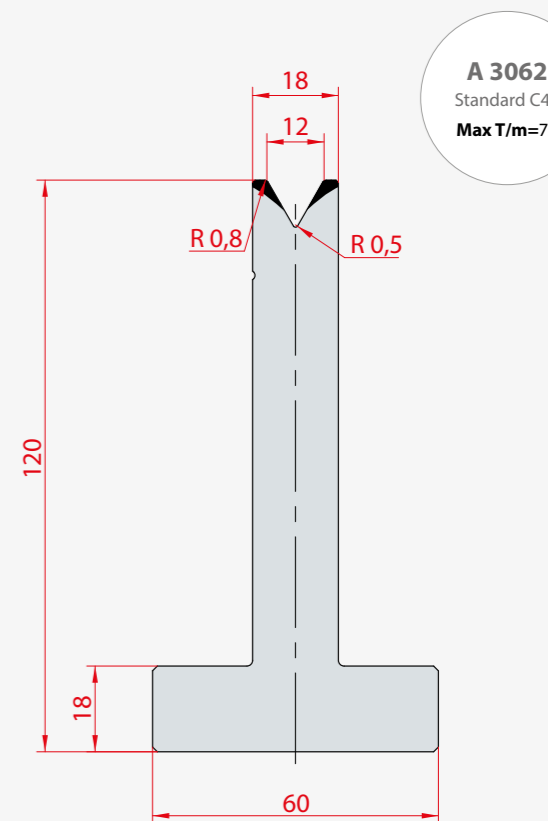
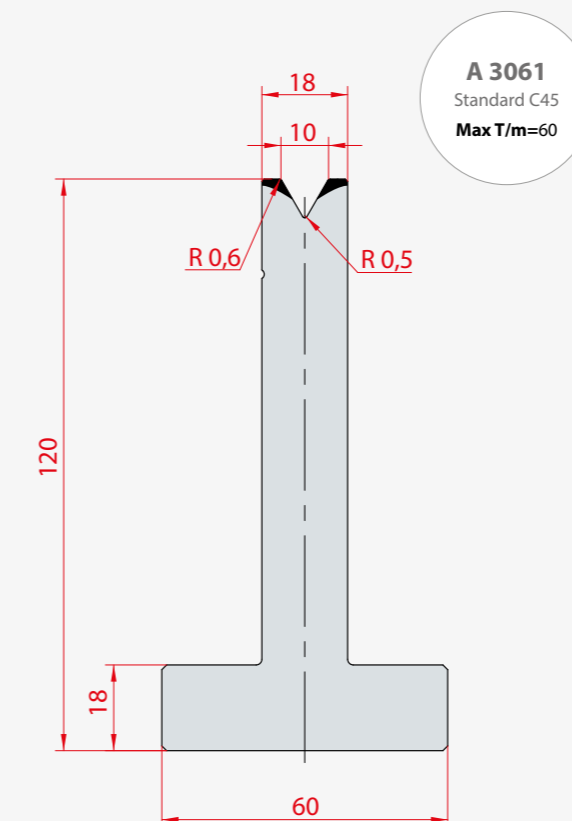
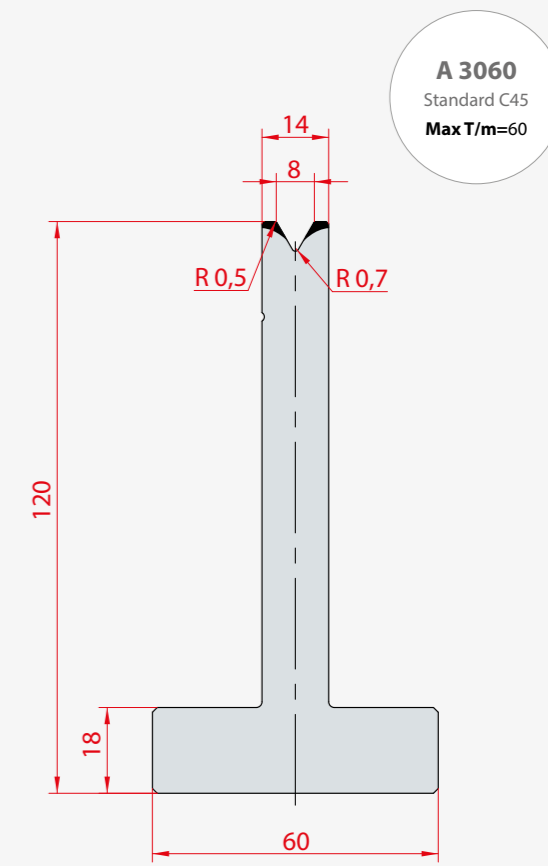
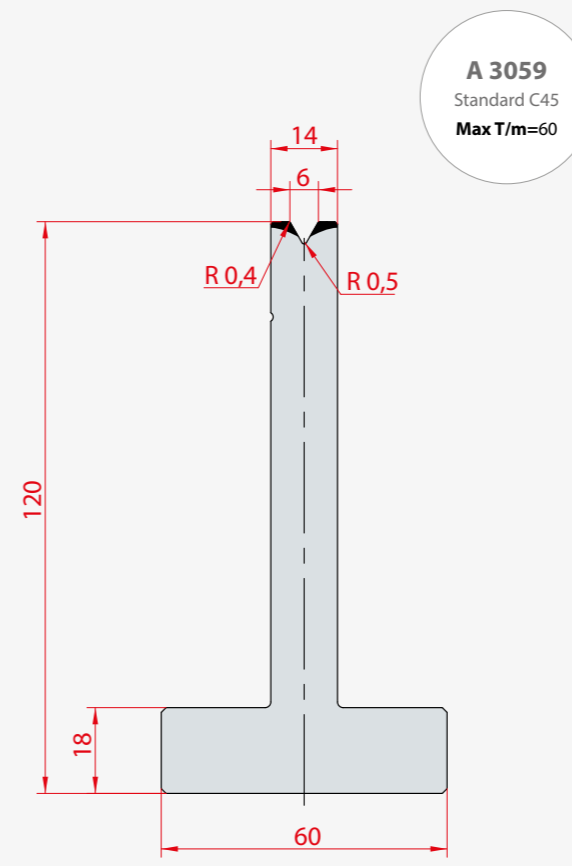

T DIES H120 60°

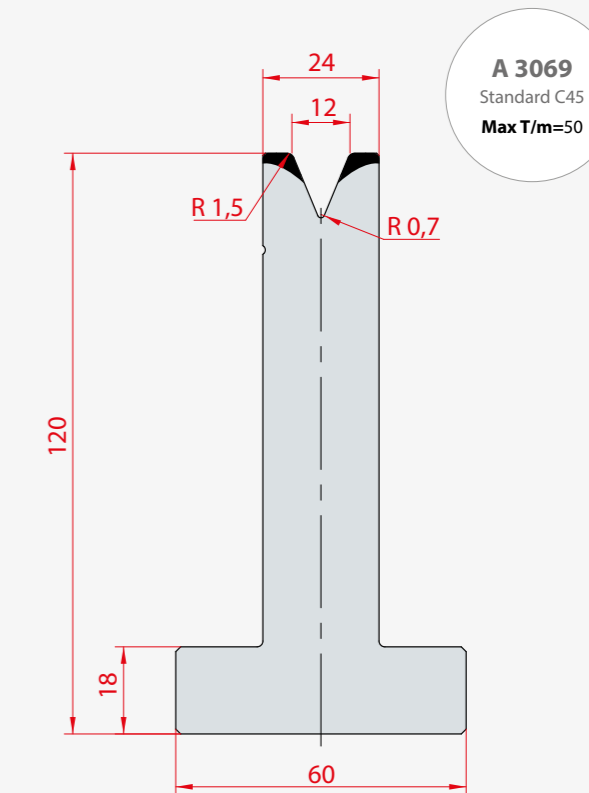
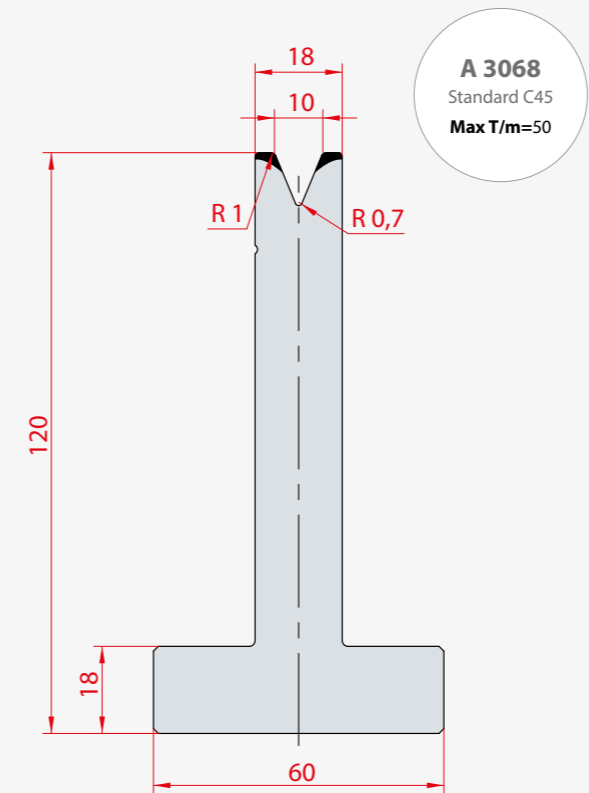
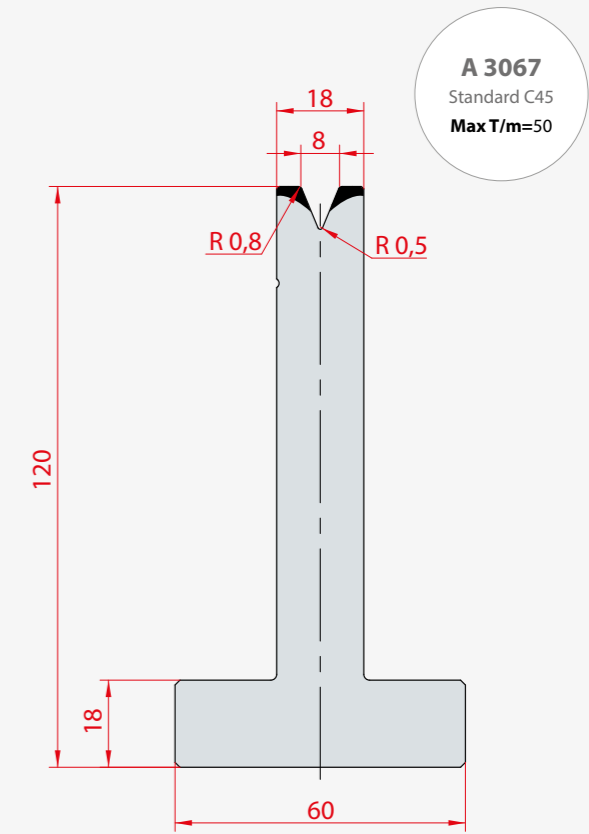
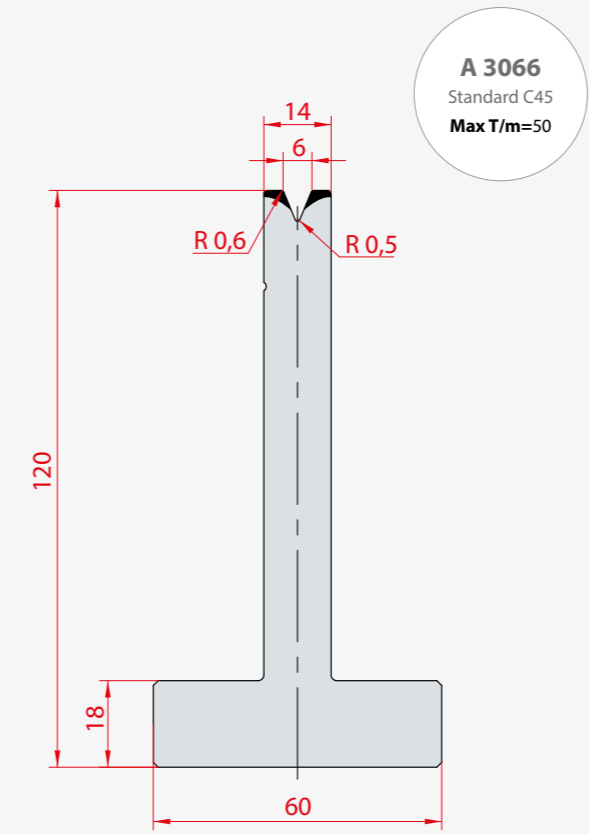
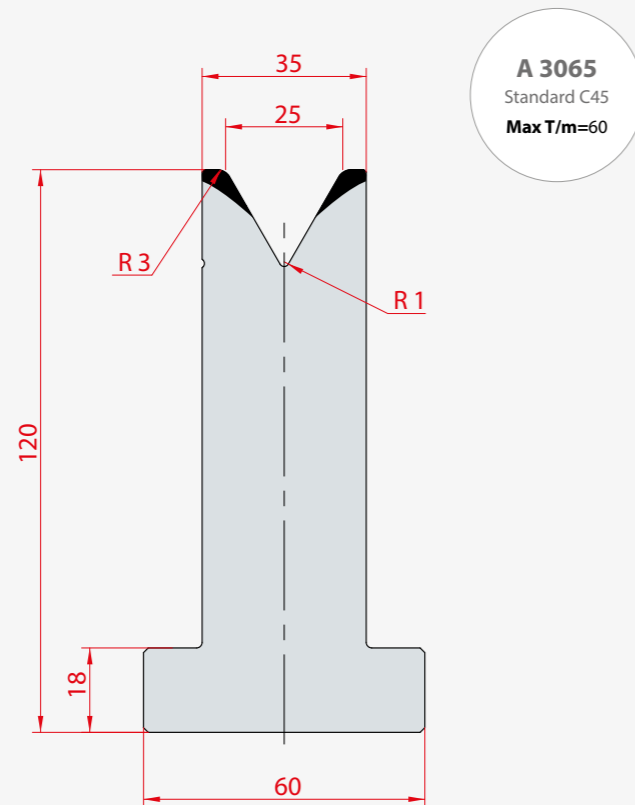
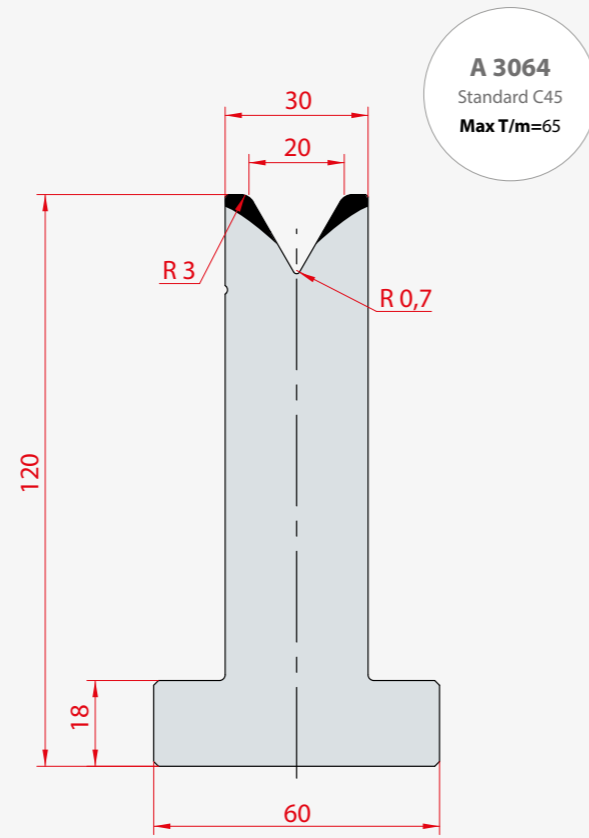
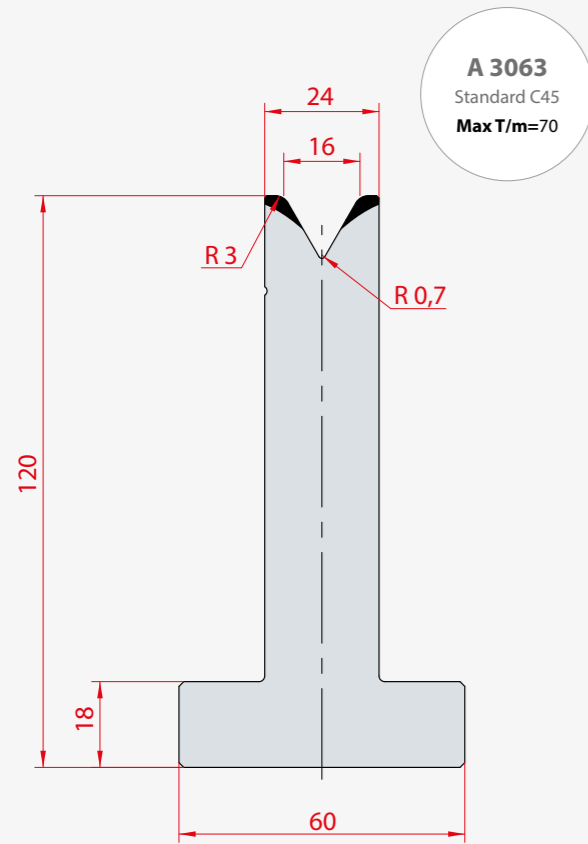

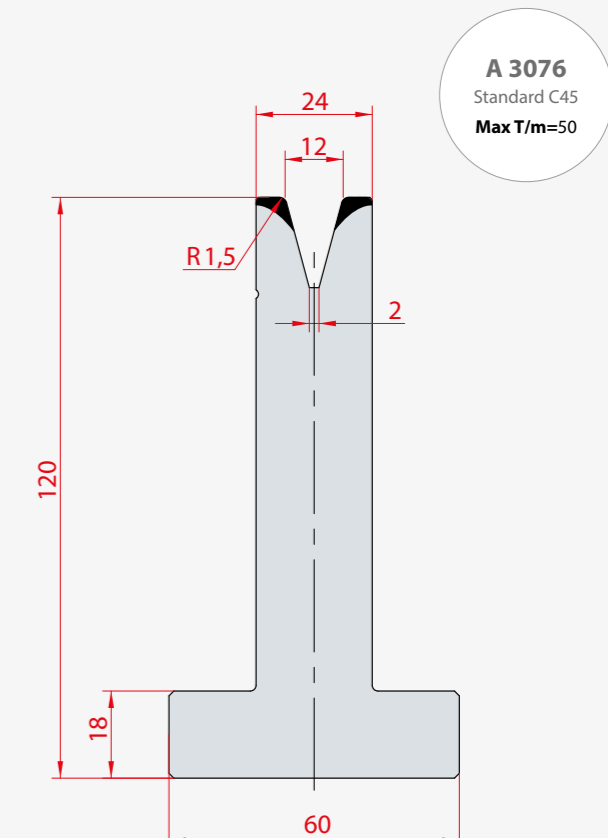
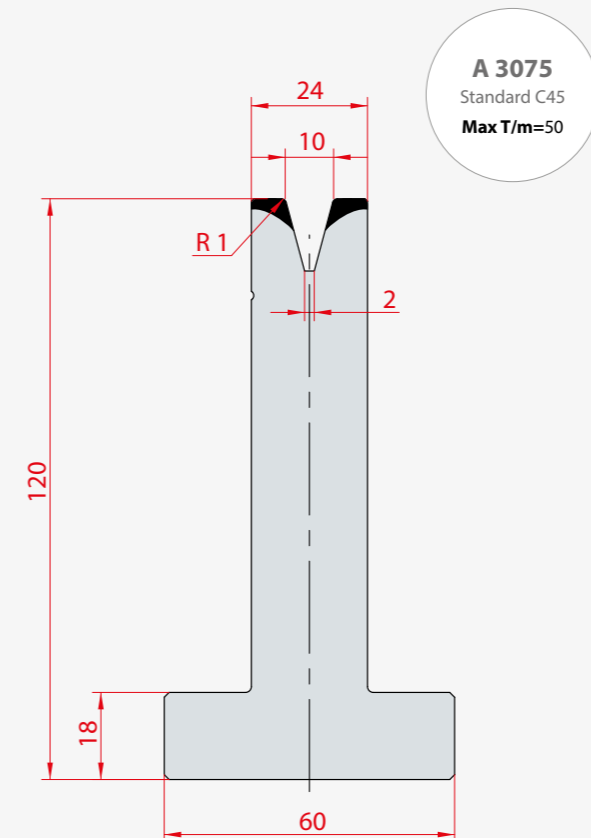
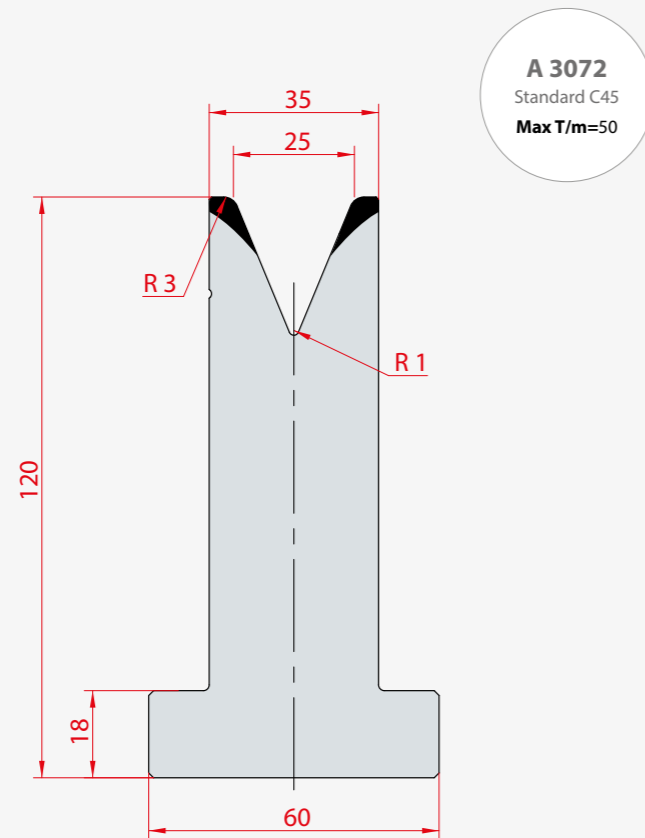
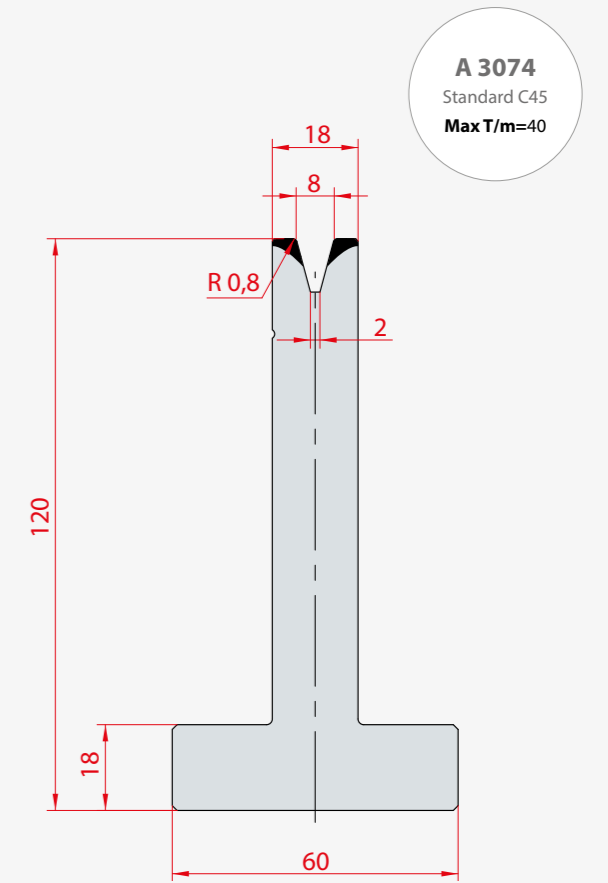
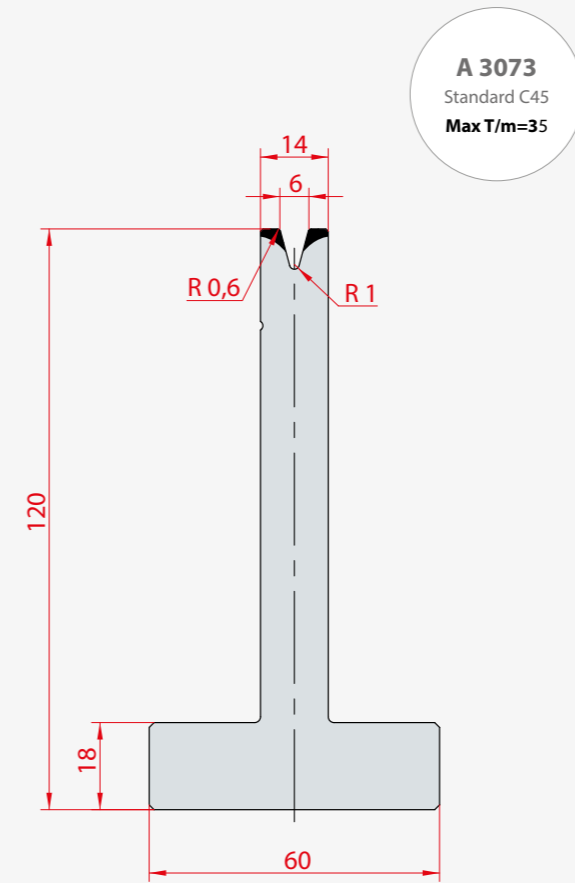
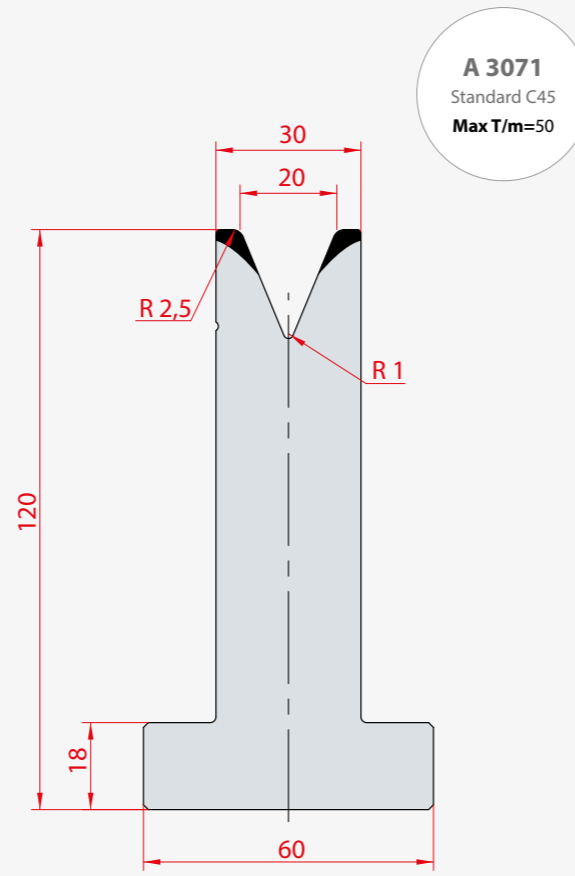
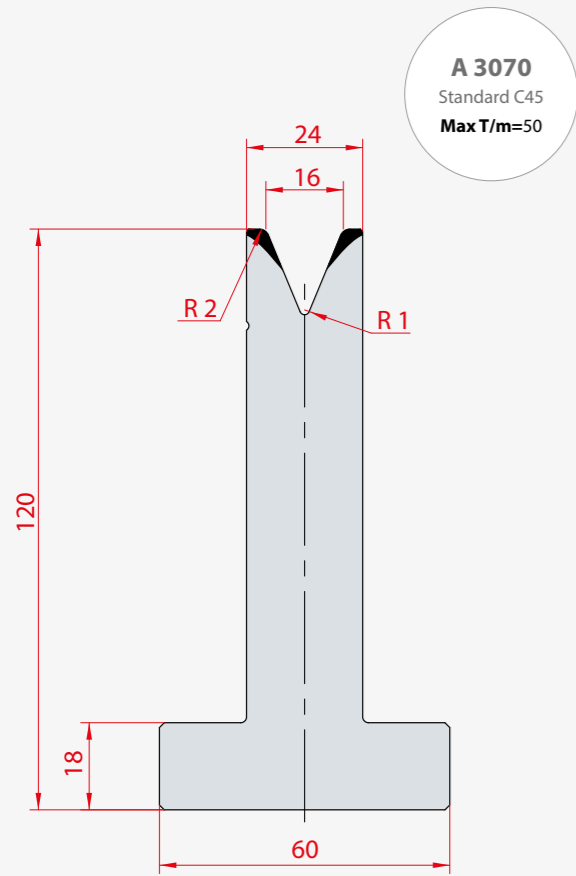

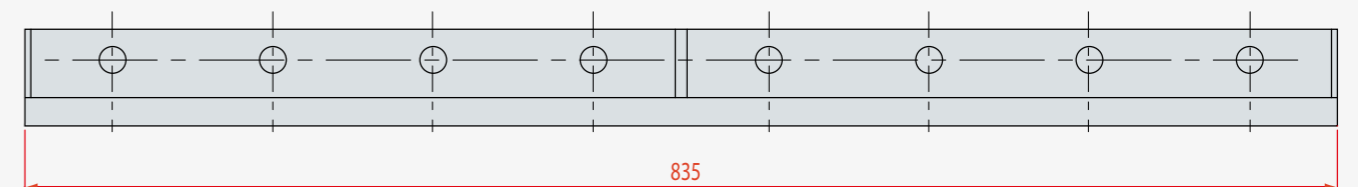
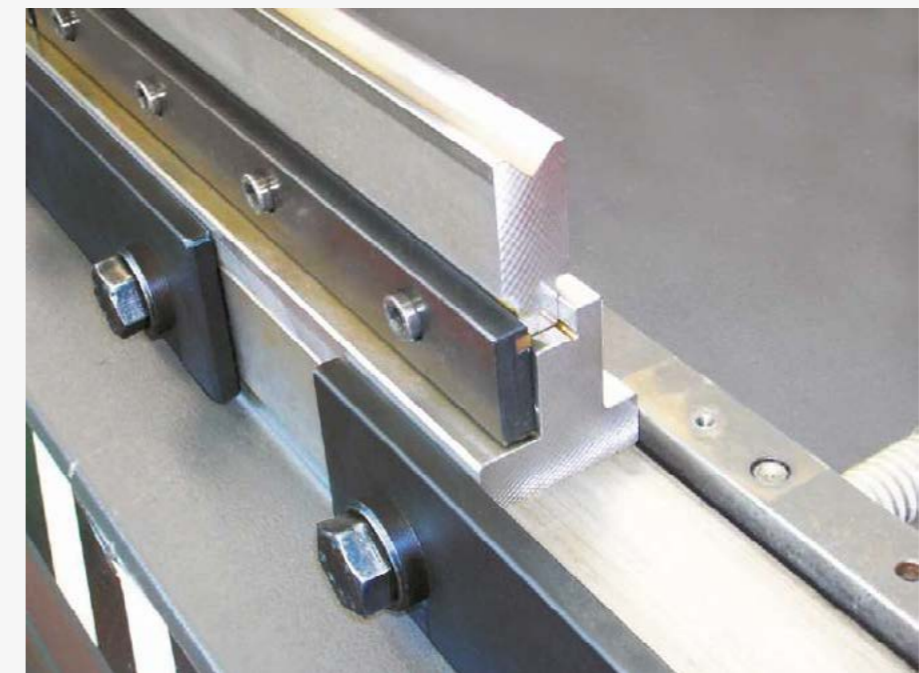
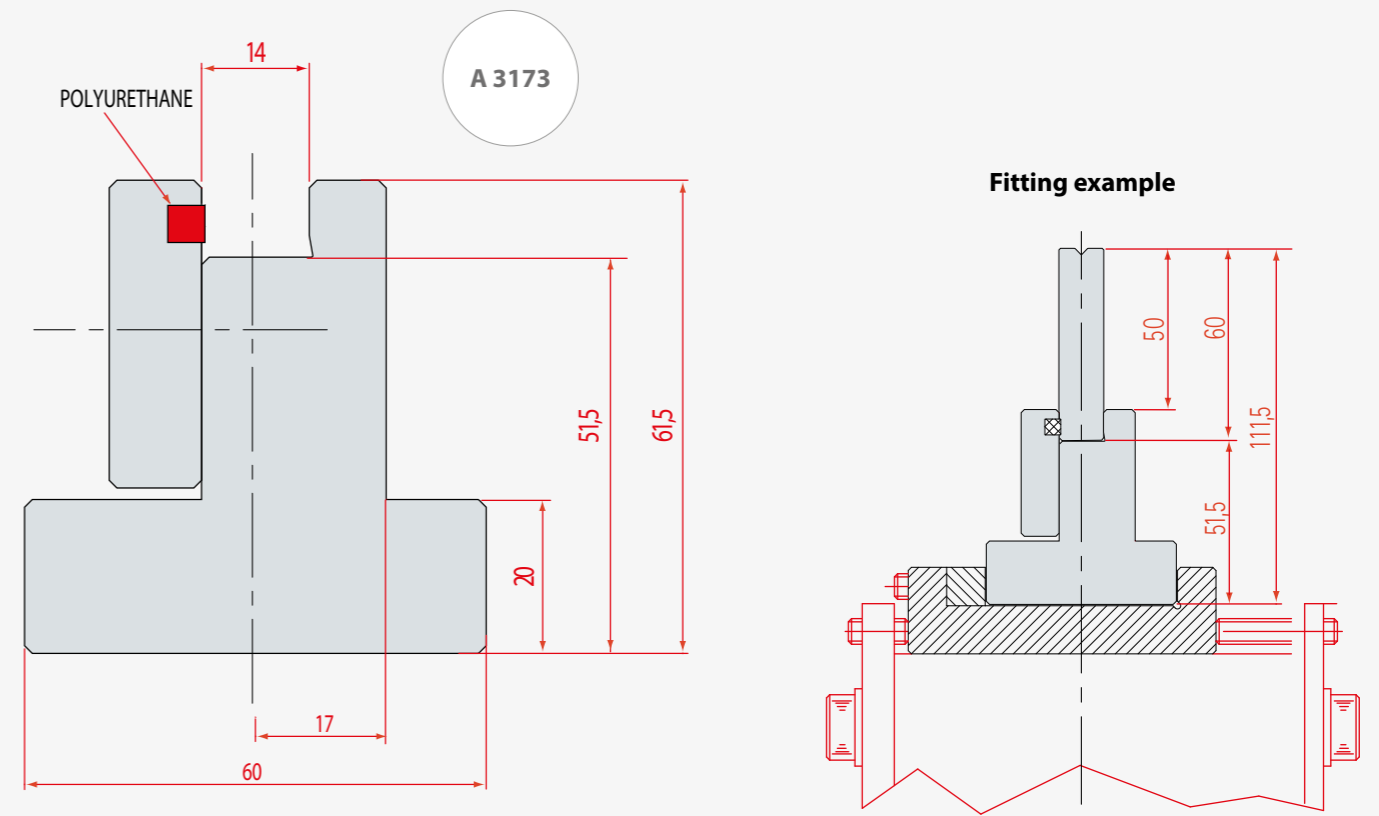
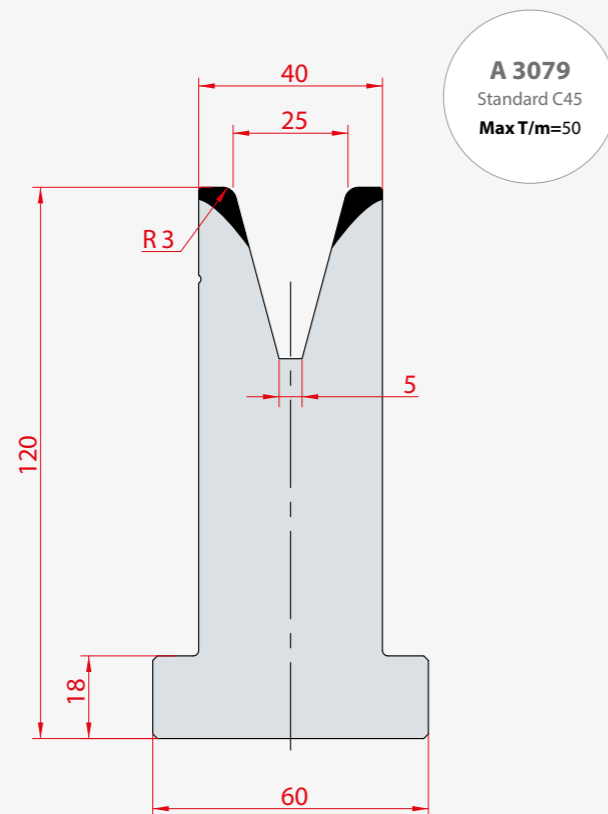
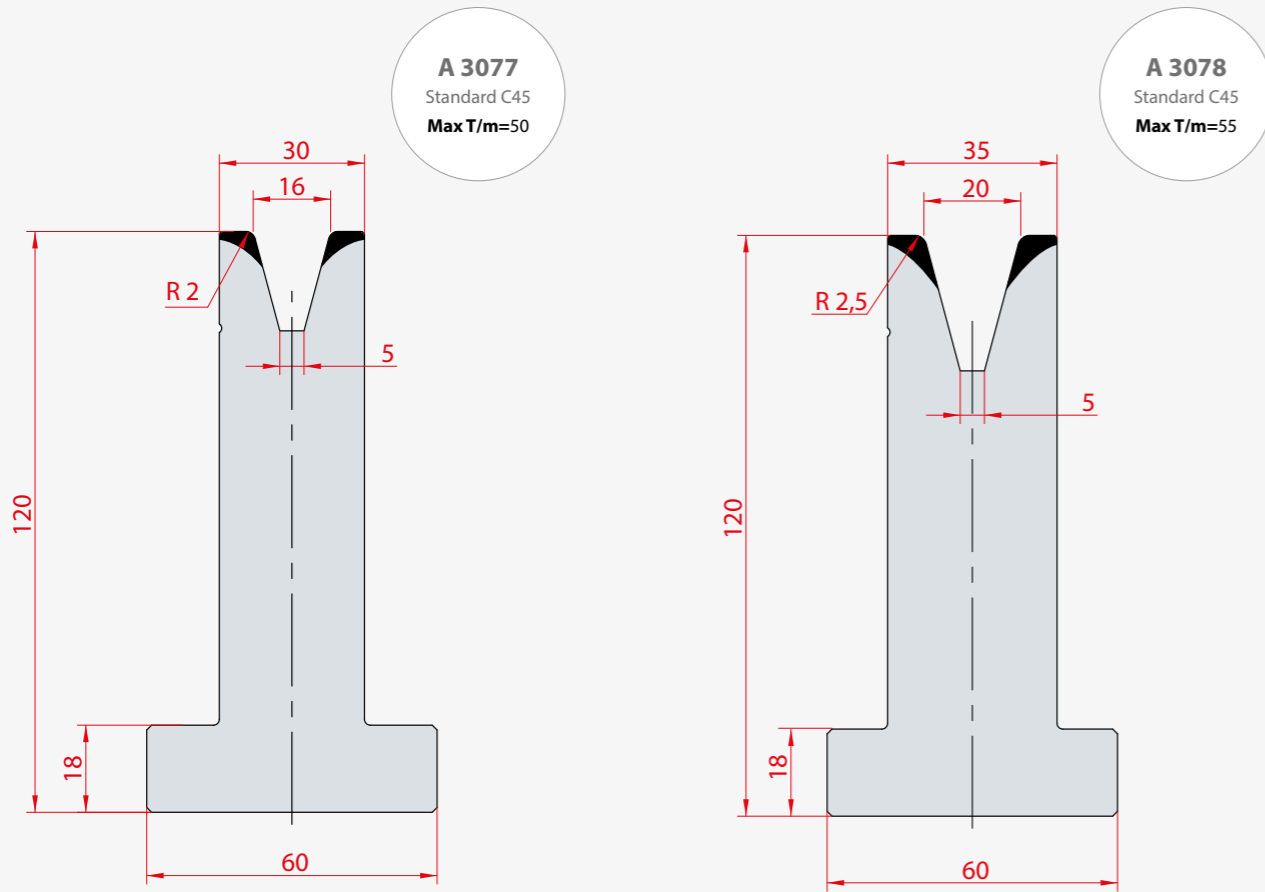

A 3158
Standard C45
Max T/m=100

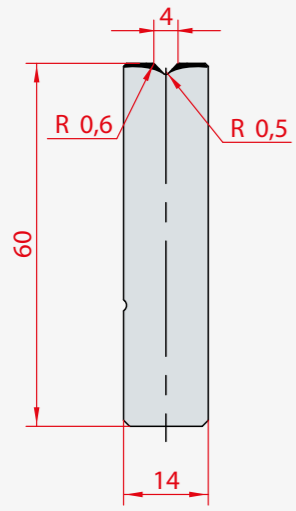

A 3159
Standard C45
Max T/m=100

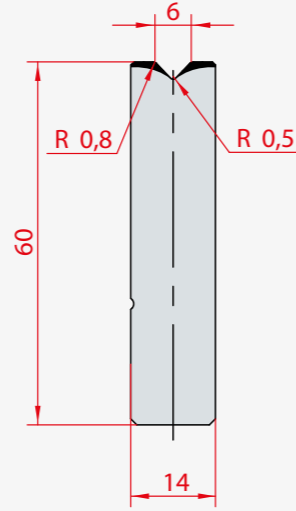

A 3162
Standard C45
Max T/m=100

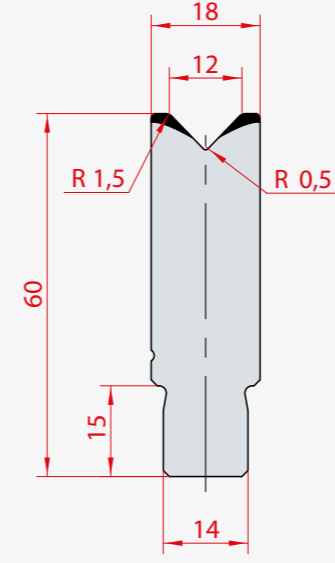

A 3163
Standard C45
Max T/m=100

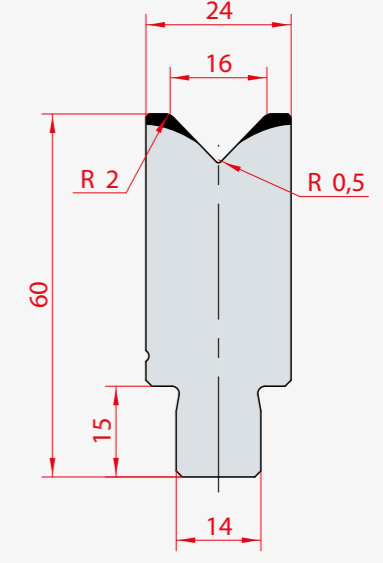

A 3160
Standard C45
Max T/m=100

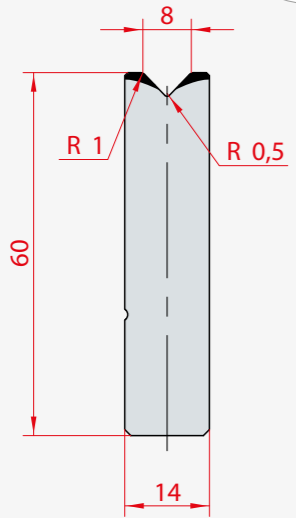

A 3161
Standard C45
Max T/m=100

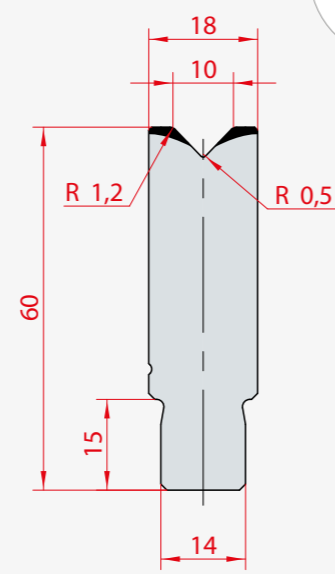

A 3164
Standard C45
Max T/m=100

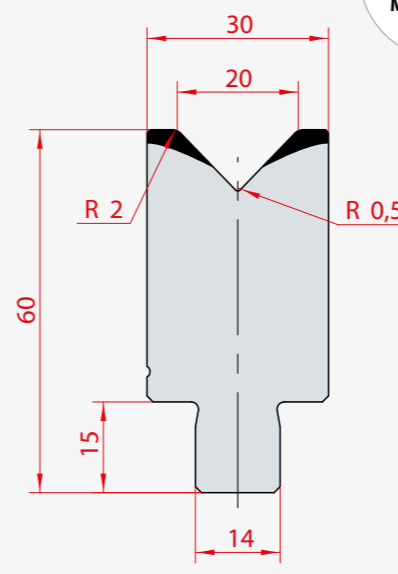

A 3165
Standard C45
Max T/m=100

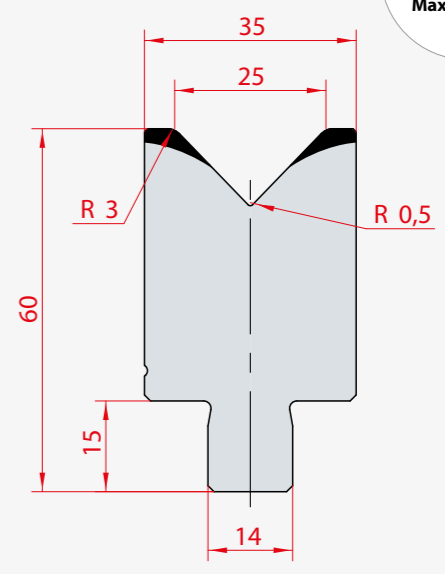

A 3193
Standard C45
Max T/m=100

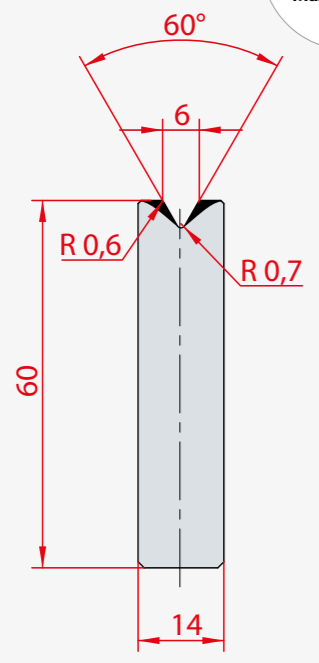

A 3194
Standard C45
Max T/m=100

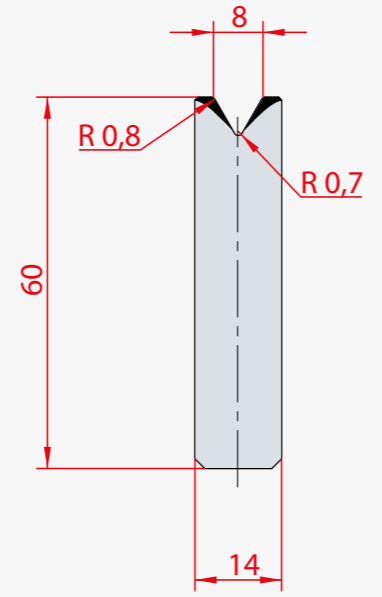

A 3197
Standard C45
Max T/m=100

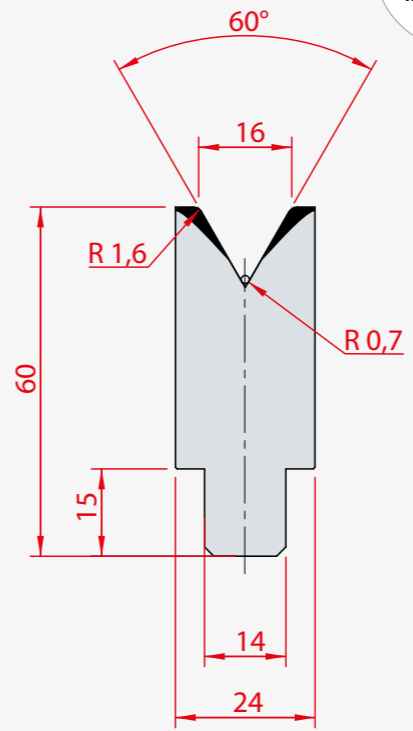

A 3198
Standard C45
Max T/m=100

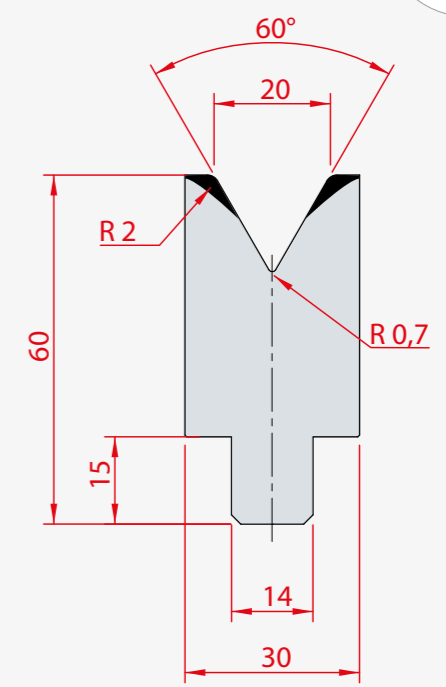

A 3195
Standard C45
Max T/m=100

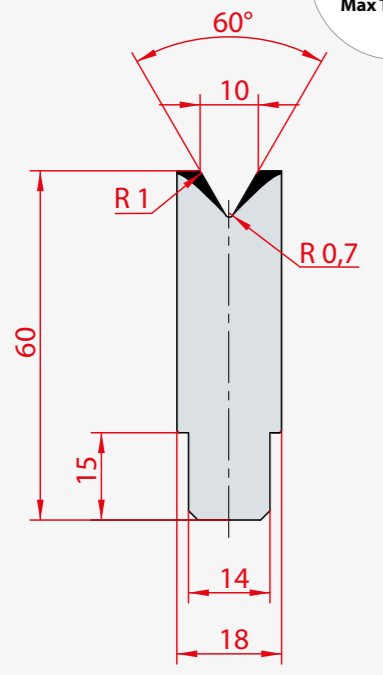

A 3196
Standard C45
Max T/m=100

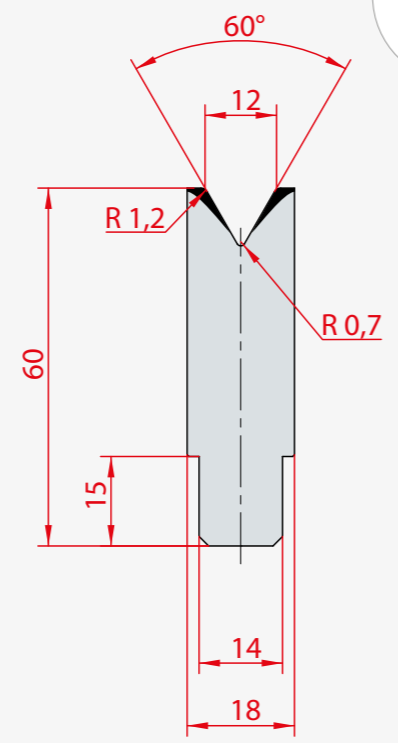

A 3199
Standard C45
Max T/m=100

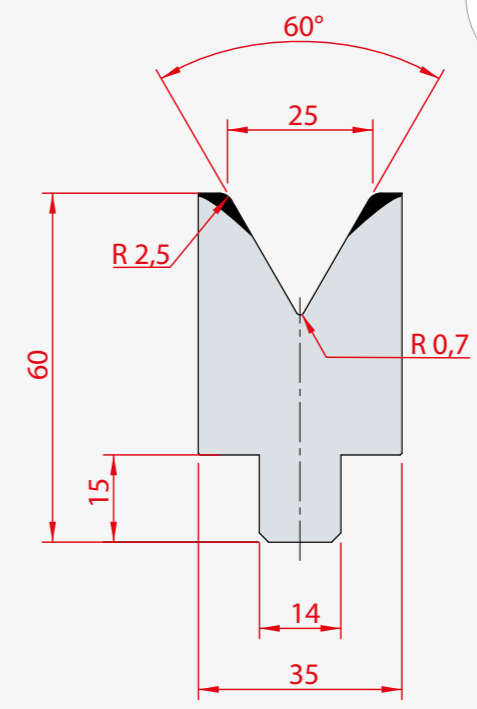

A 3166
Standard C45
Max T/m=35

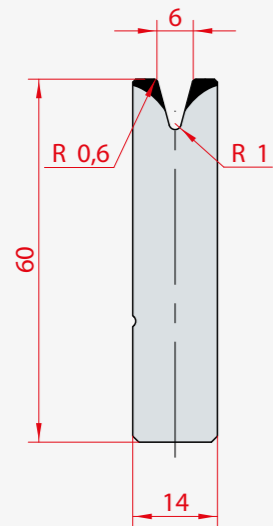

A 3167
Standard C45
Max T/m=40

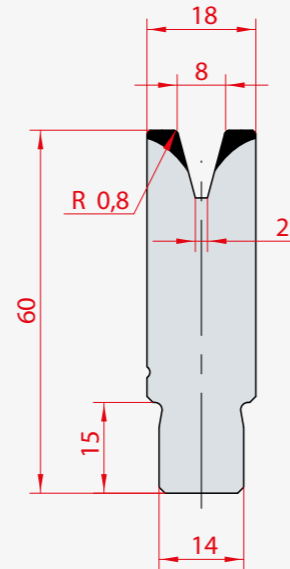

A 3170
Standard C45
Max T/m=50

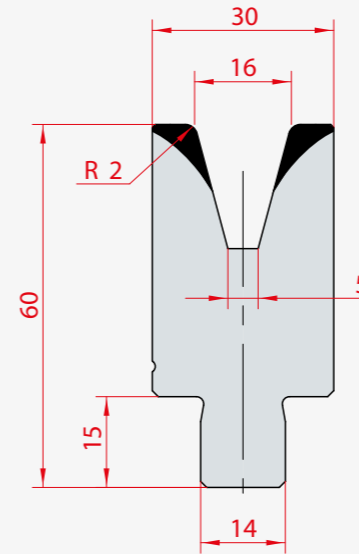

A 3171
Standard C45
Max T/m=55

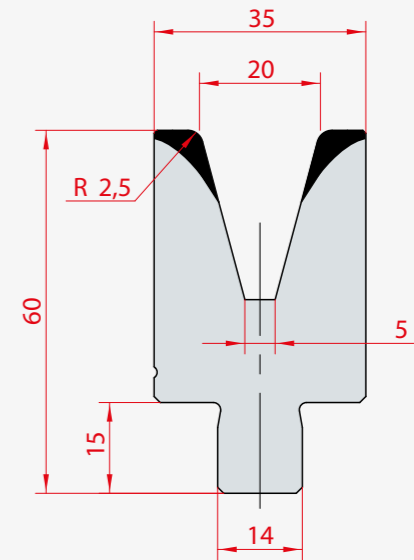

A 3168
Standard C45
Max T/m=50

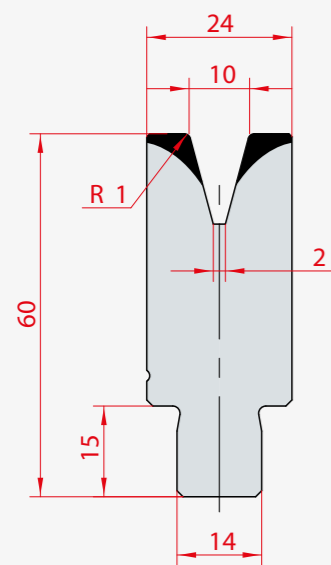

A 3169
Standard C45
Max T/m=50

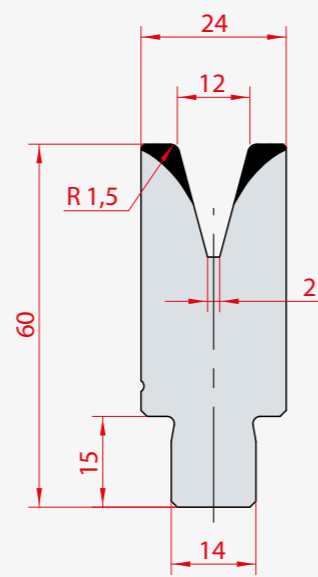

A 3172
Standard C45
Max T/m=55

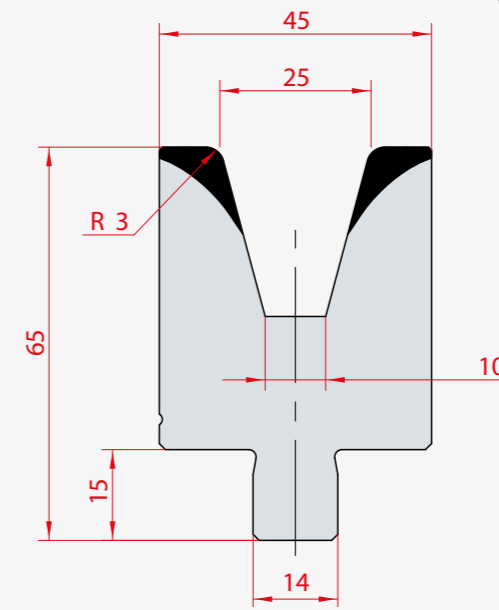

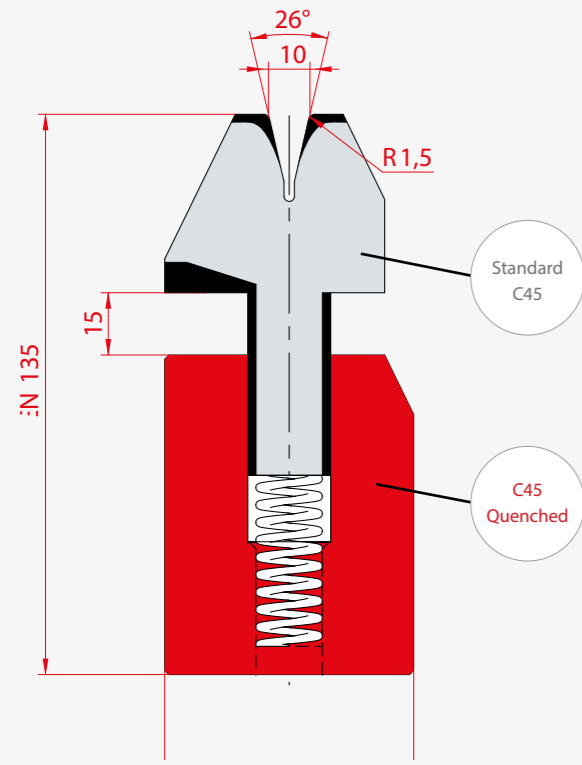

A 3038
Max T/m=100
Sheet thickness : from 1,5 to 2,5 mm

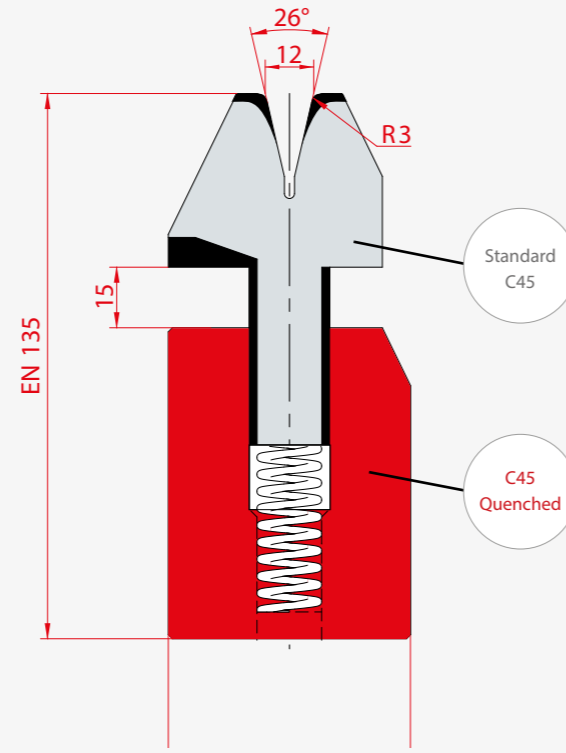

A 3040
Max T/m=100
Sheet thickness : from 1,5 to 3,0 mm

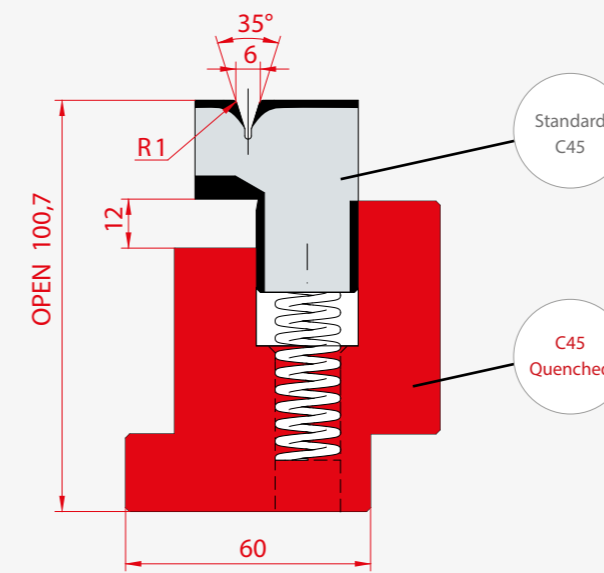

A 3037/6
Max T/m=60
Sheet thickness : max 1,0 mm

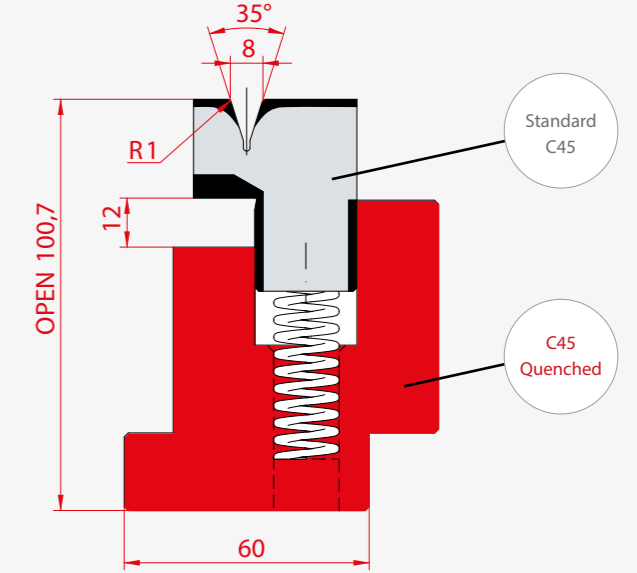

A 3037/8
Max T/m=60
Sheet thickness : max 1,2 mm

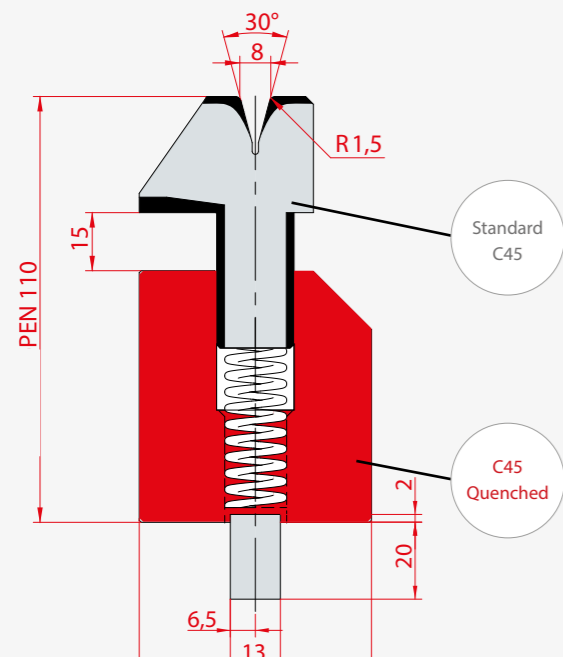

A 3041
Max T/m=80
Sheet thickness : max 1,5 mm

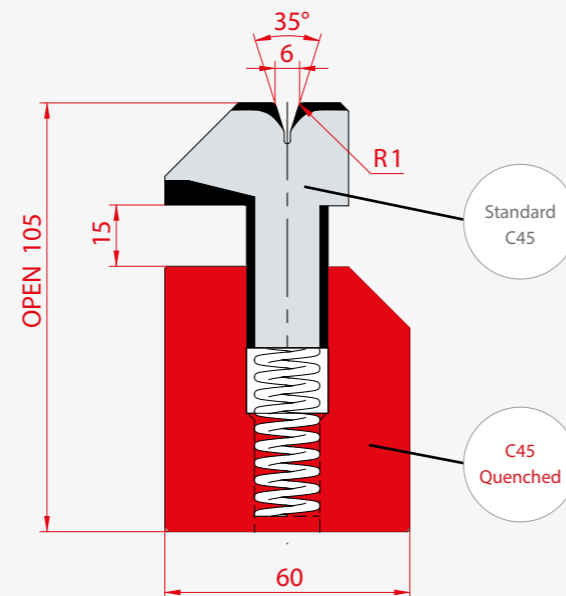

A 3039
Max T/m=80
Sheet thickness : max 1,0 mm

Bending chart

Mild Steel R.45 Kg/mm²

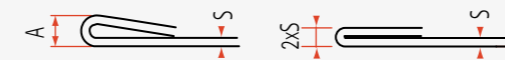

S mm	A mm	Ton /M	2xS	Ton /M
0,6	3	9	1,2	23
0,8	3	12	1,6	32
1	3,5	15	2	40
1,25	3,5	17	2,5	50
1,5	4,6	22	3	63
2	5,5	30	4	80
2,5	6,5	55	5	90
3	8	70	6	100

Stainless Steel R.70 Kg/mm²

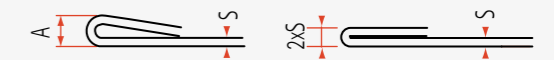

S mm	A mm	Ton /M	2xS	Ton /M
0,6	3	15	1,2	35
0,8	3	20	1,6	50
1	3,5	25	2	60
1,25	3,5	26	2,5	80
1,5	4,6	38	3	95
2	5,5	50	4	130

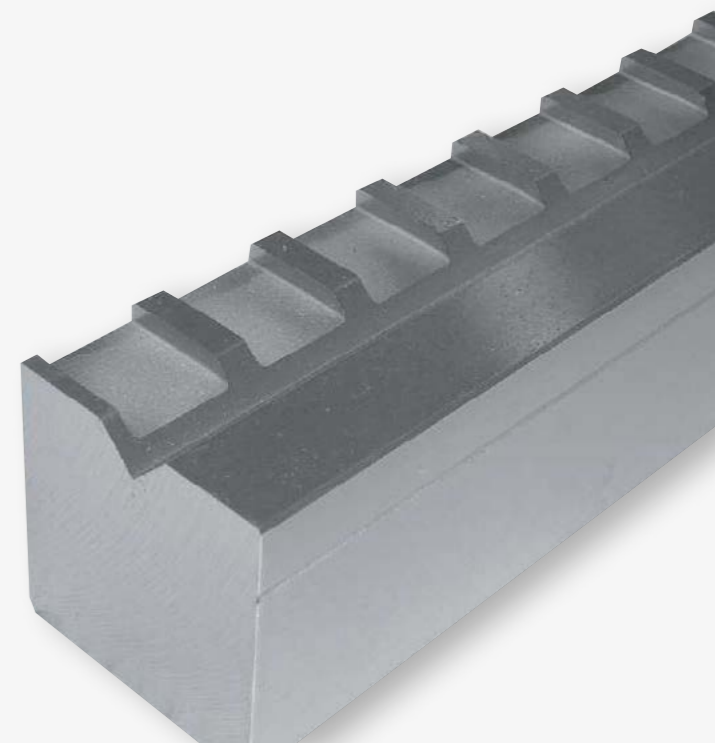
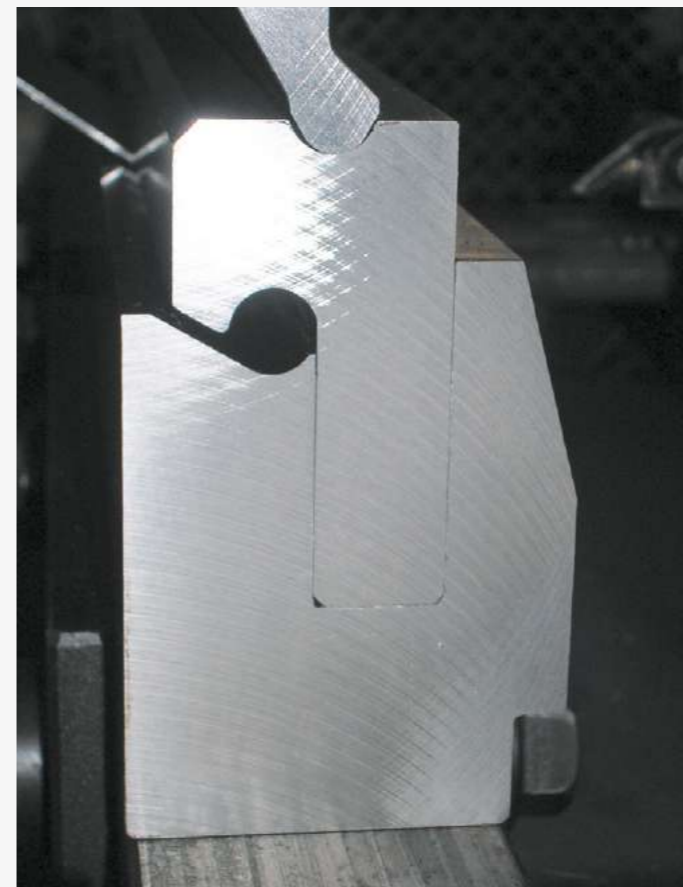
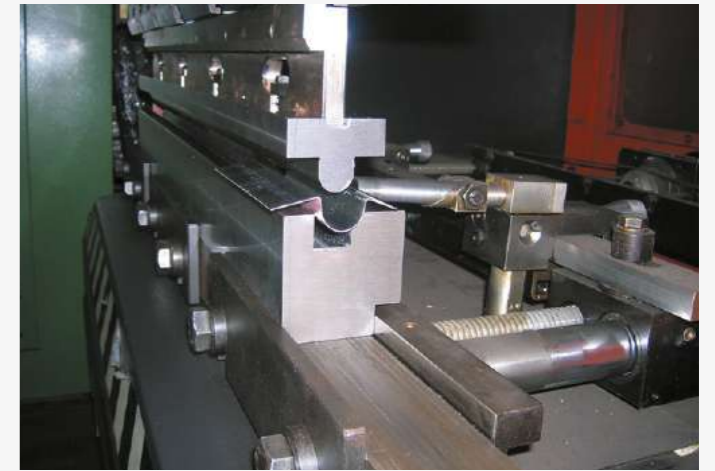
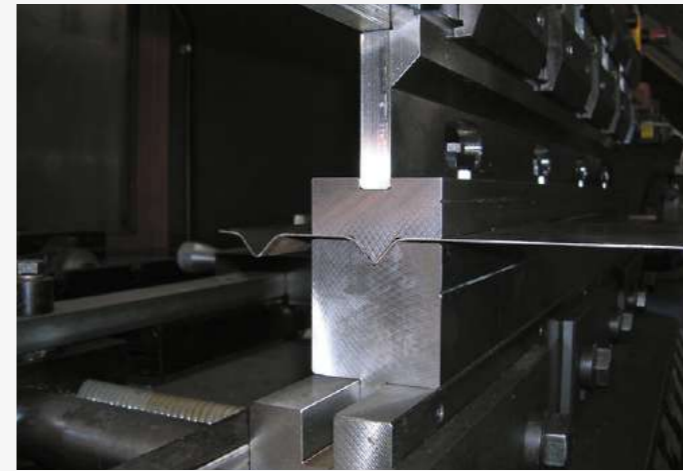
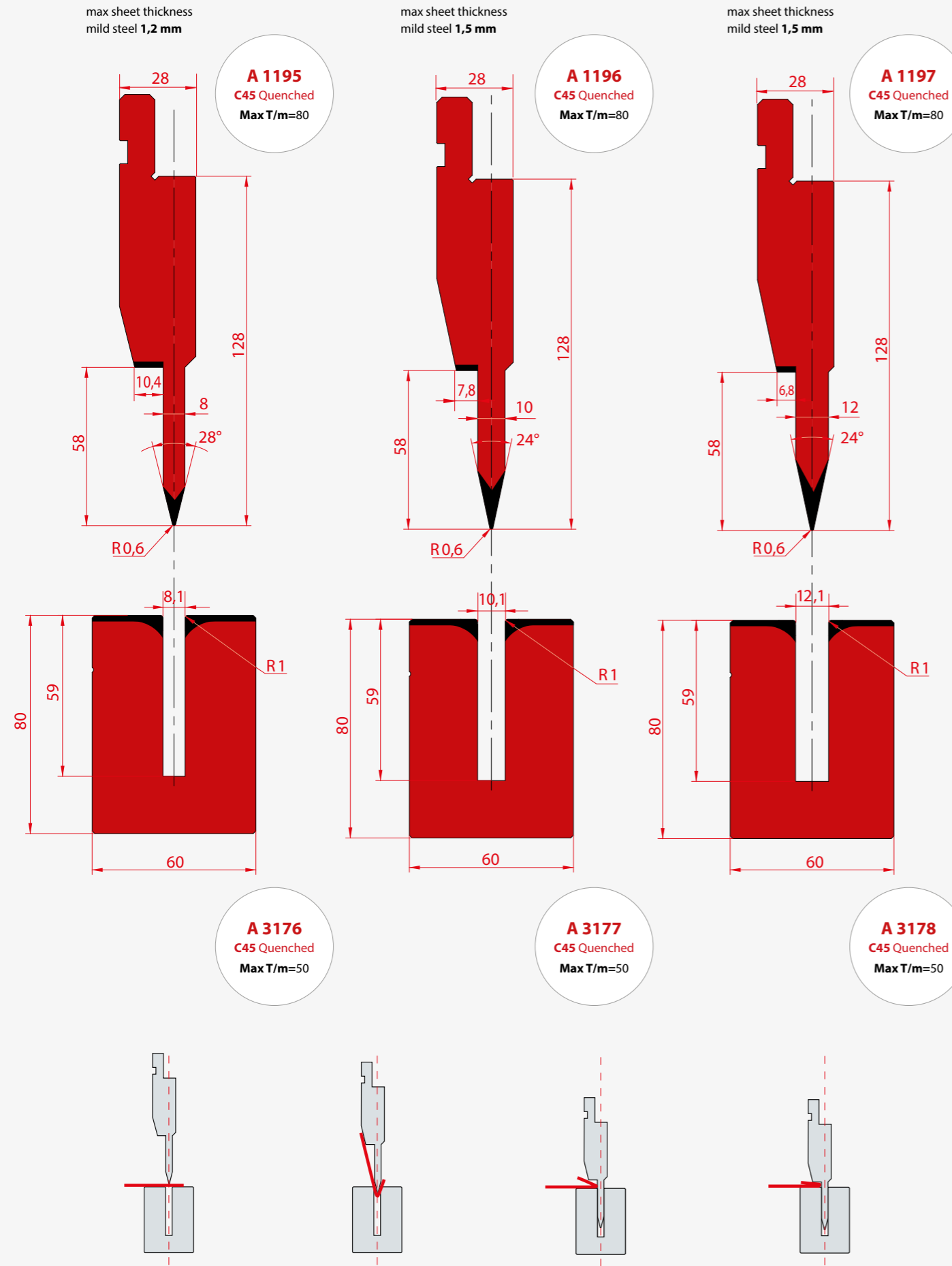

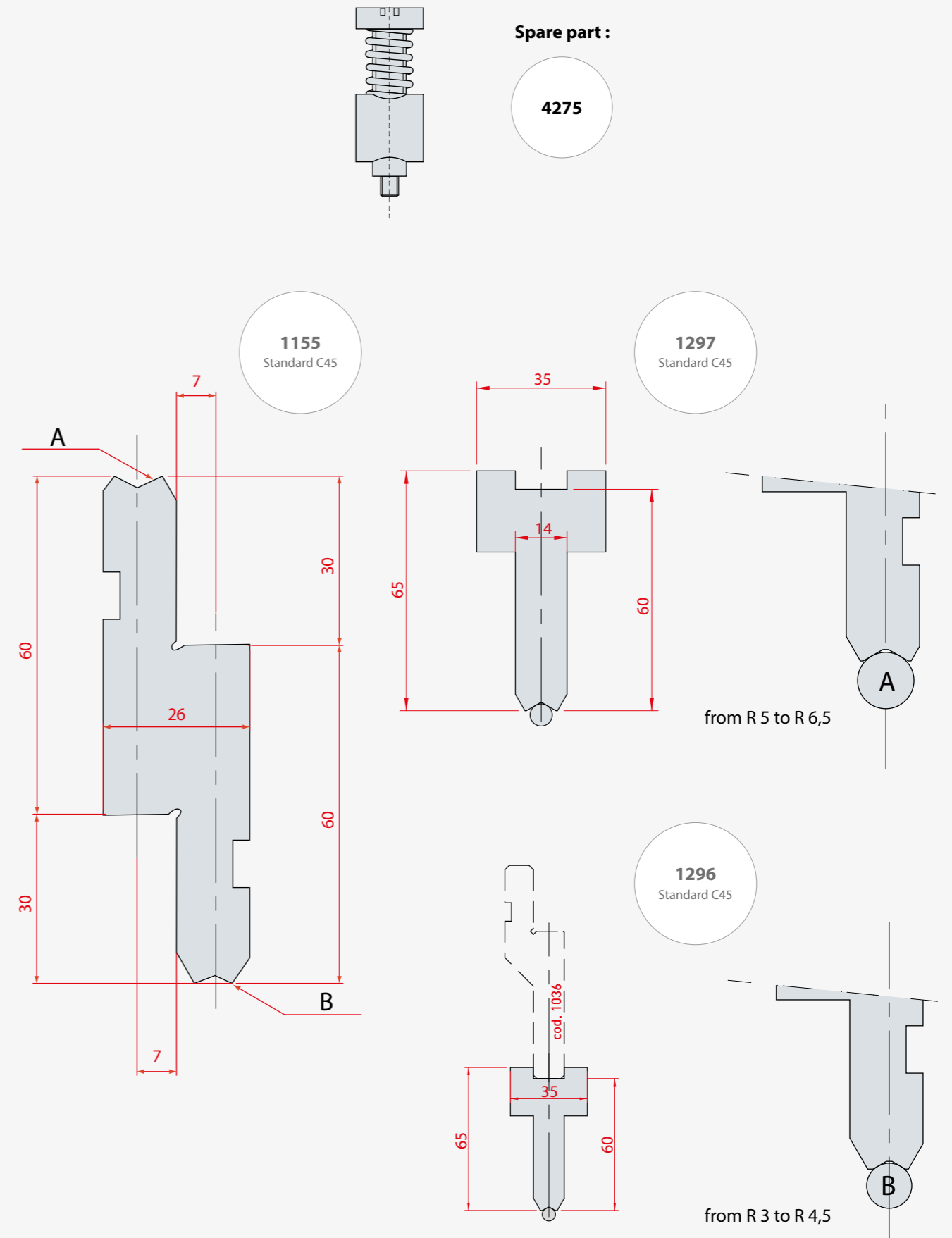
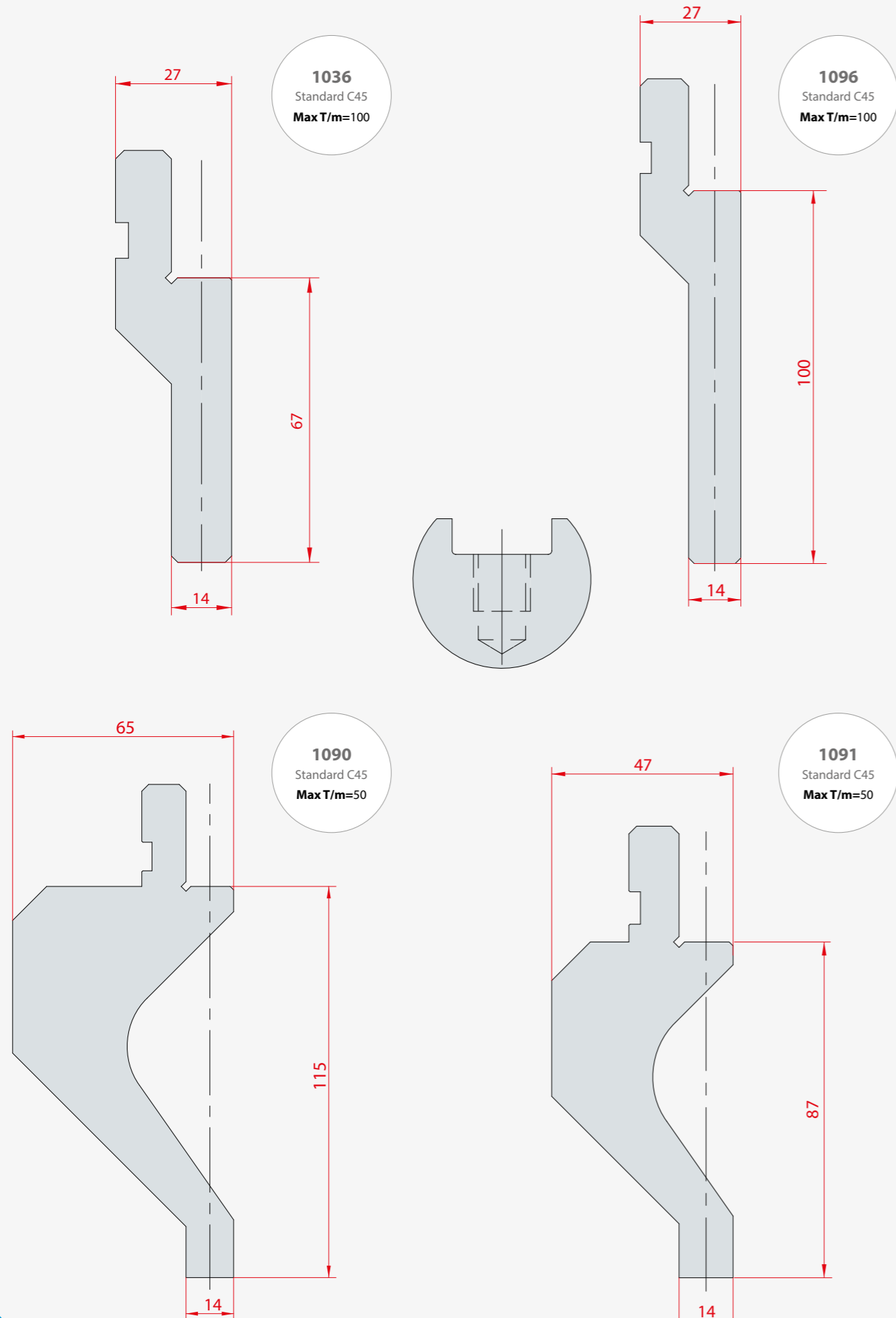

ONLY FOR HOLDERS 1155 - 1296 - 1297

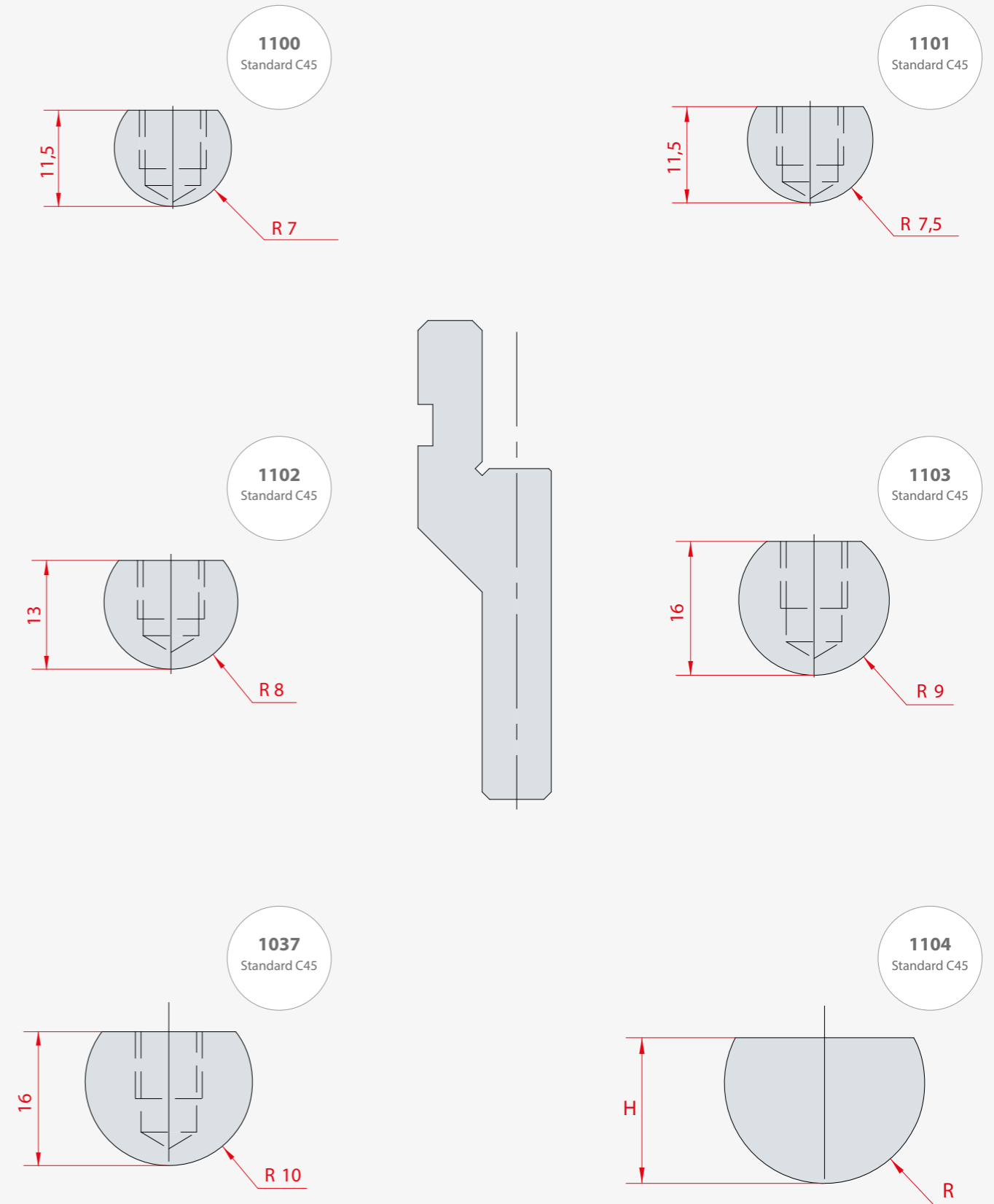
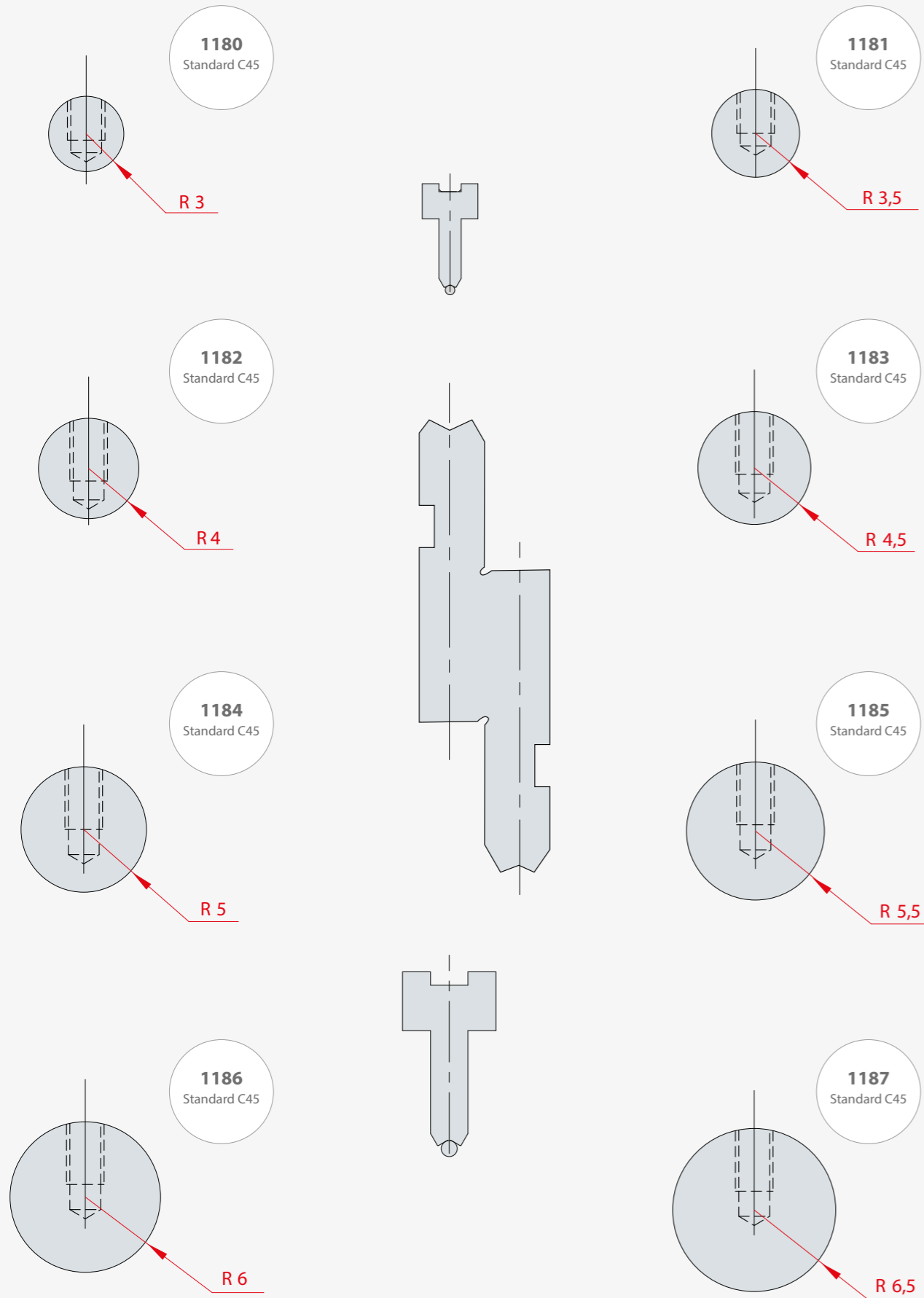

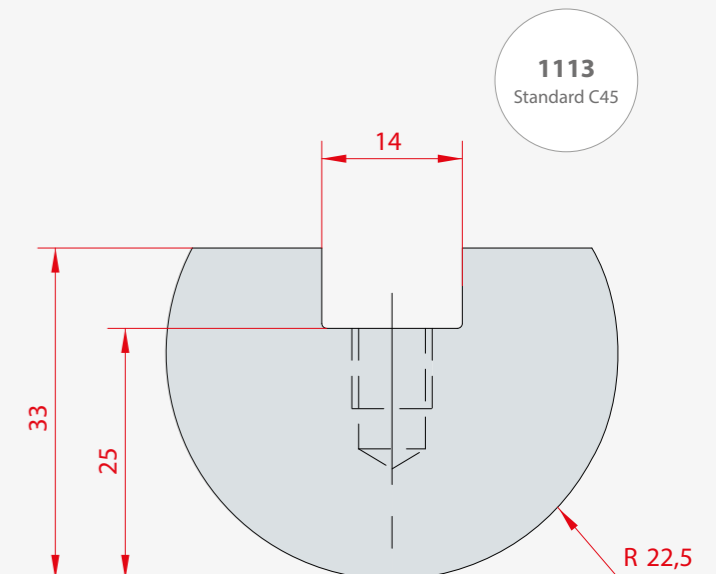
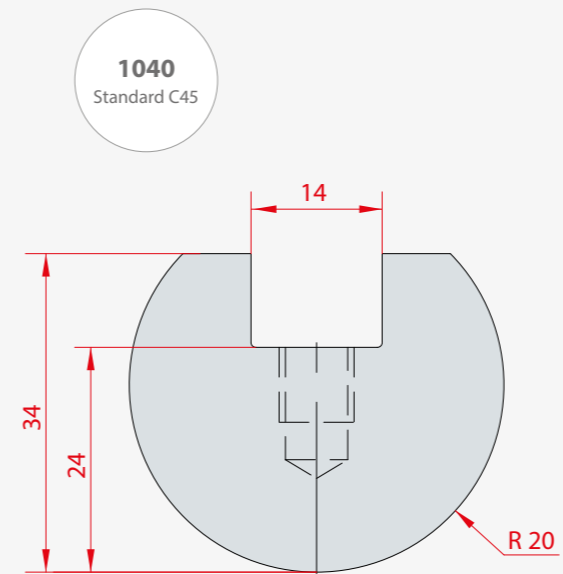
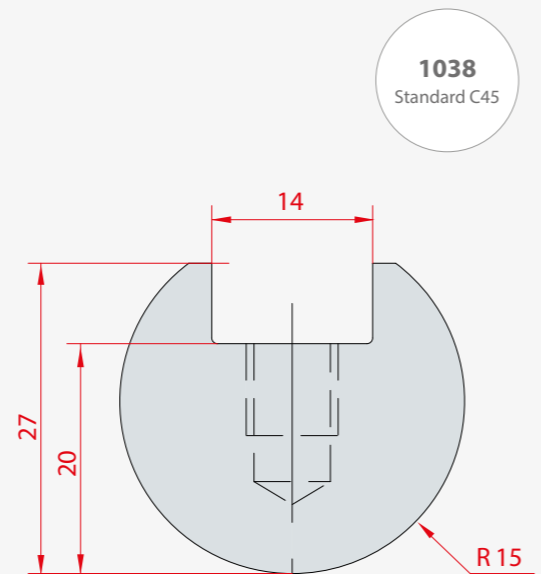
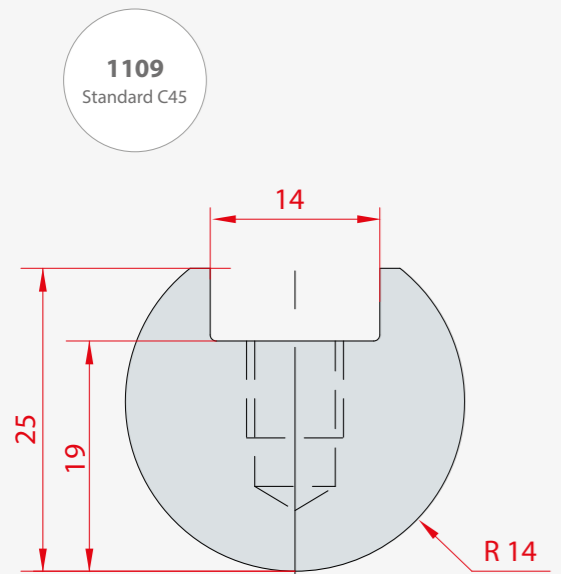
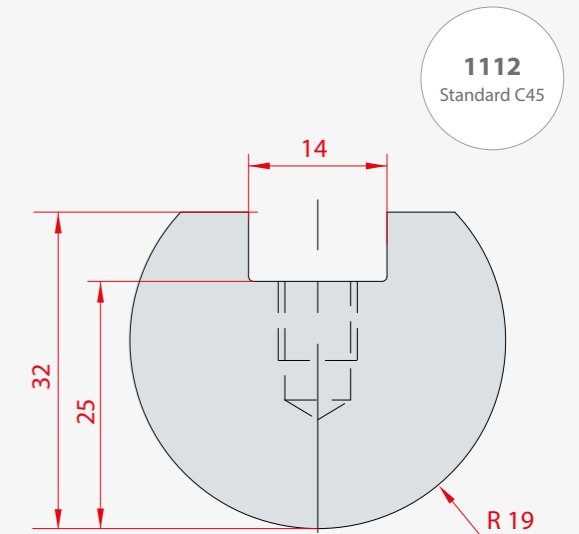
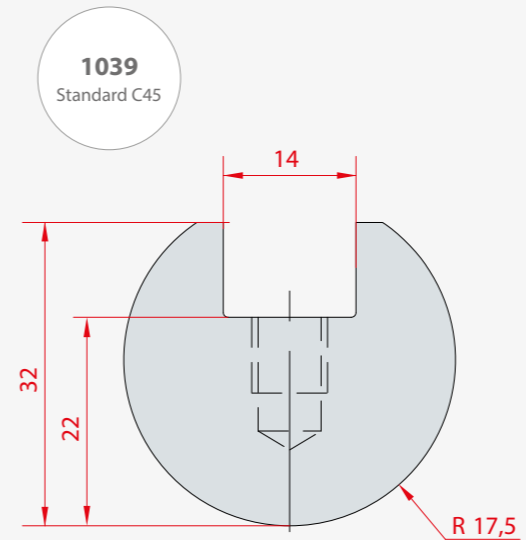
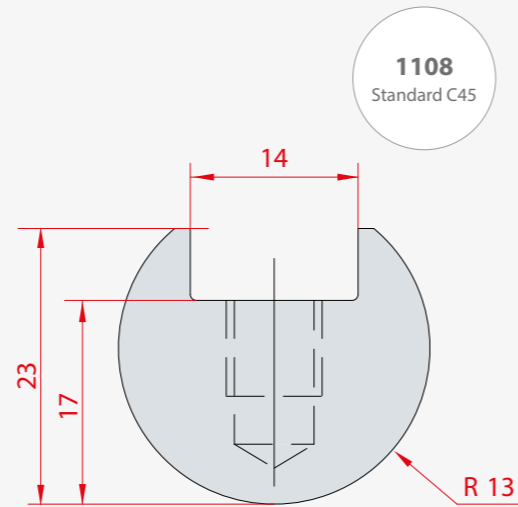
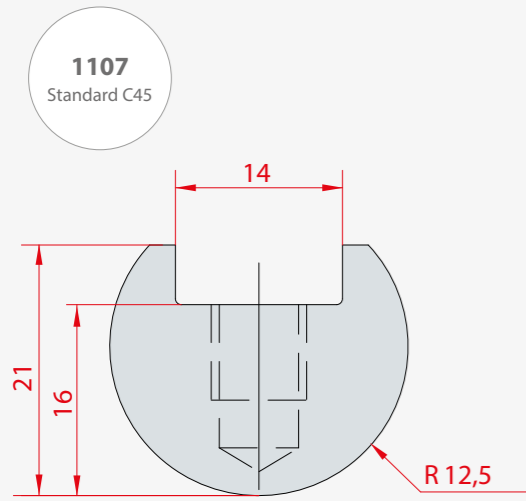
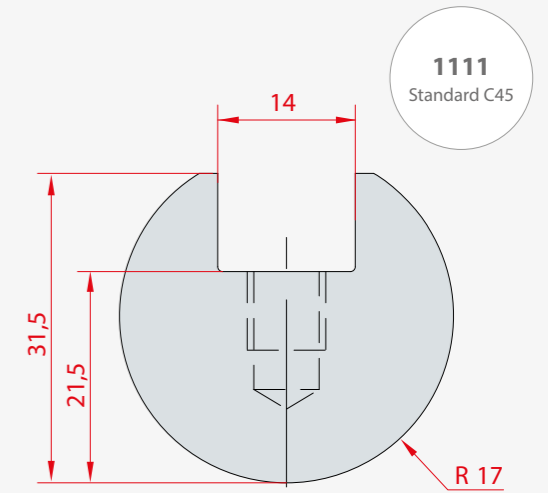
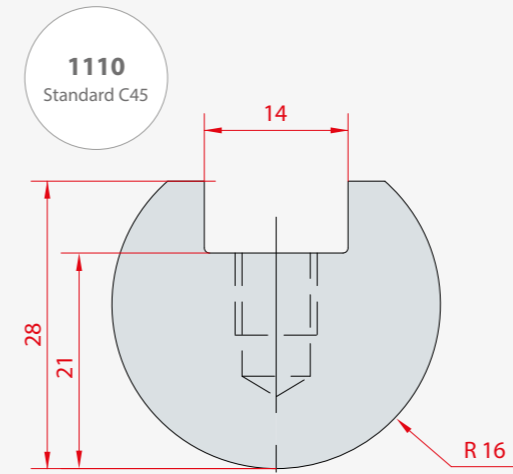
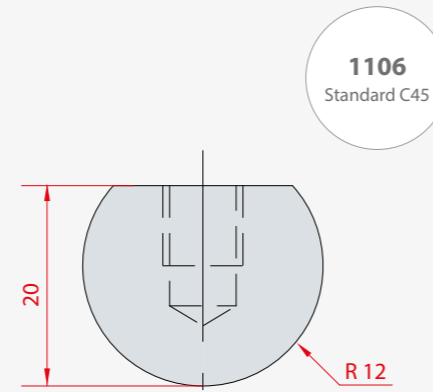
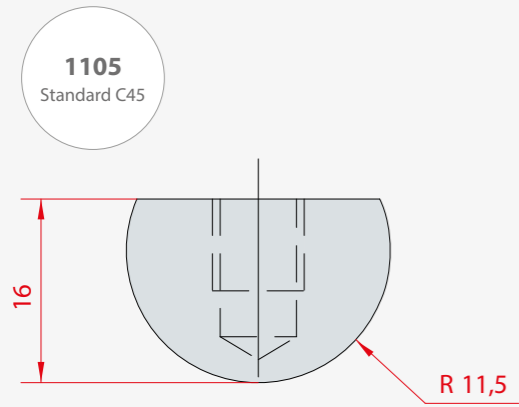

RADIUS TOOLS

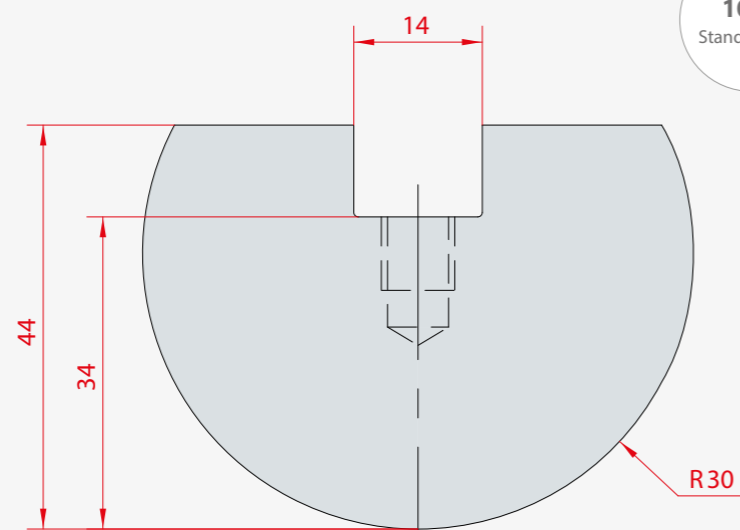
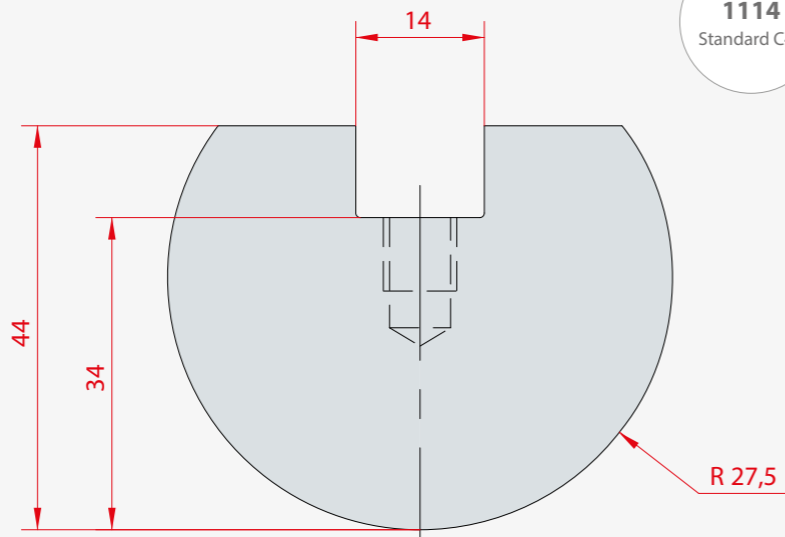
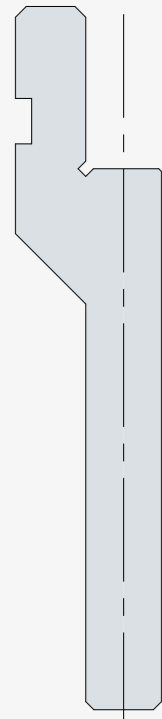
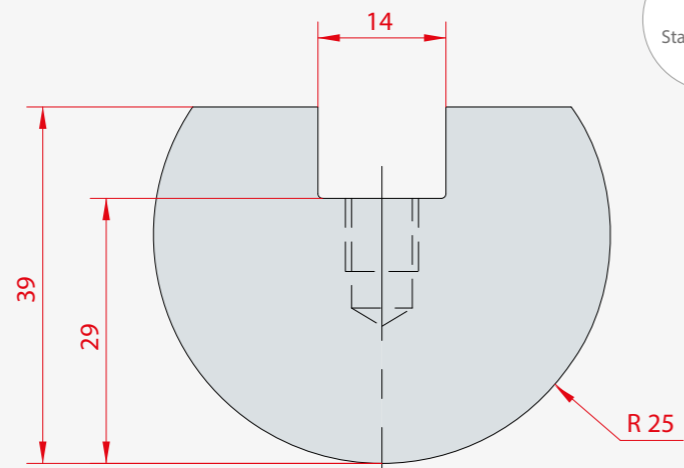

RADIUS TOOLS

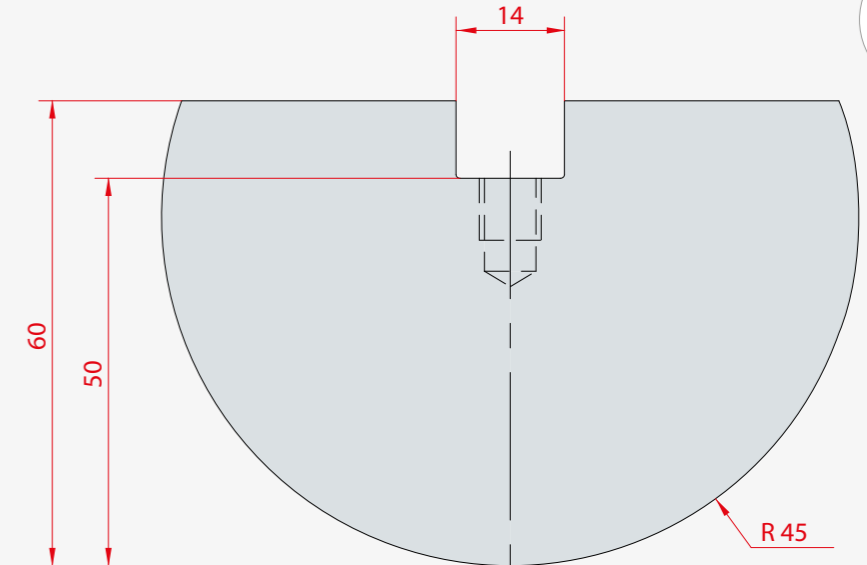
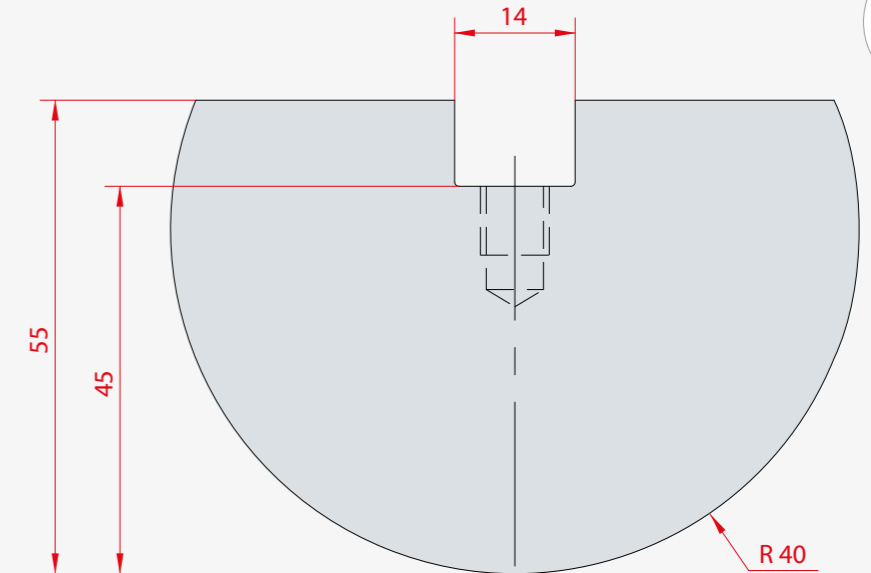
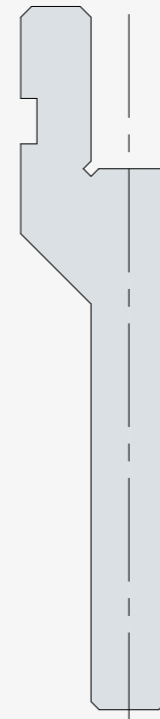
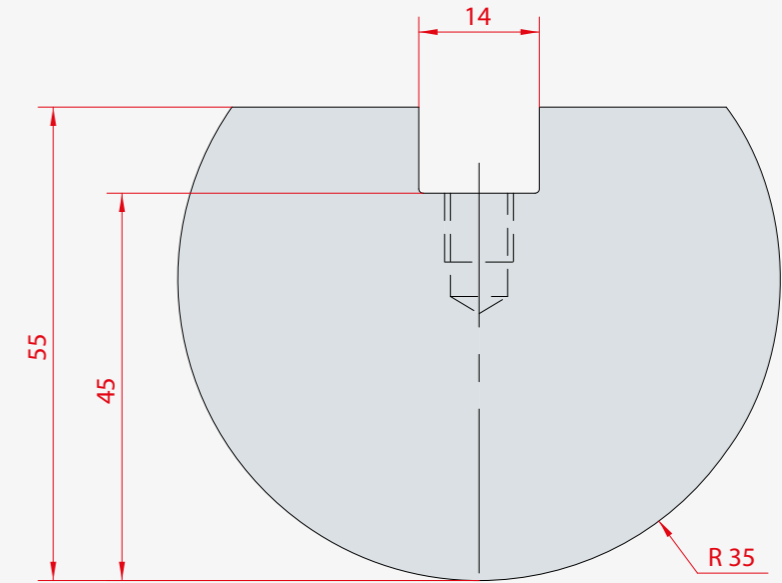

RADIUS TOOLS

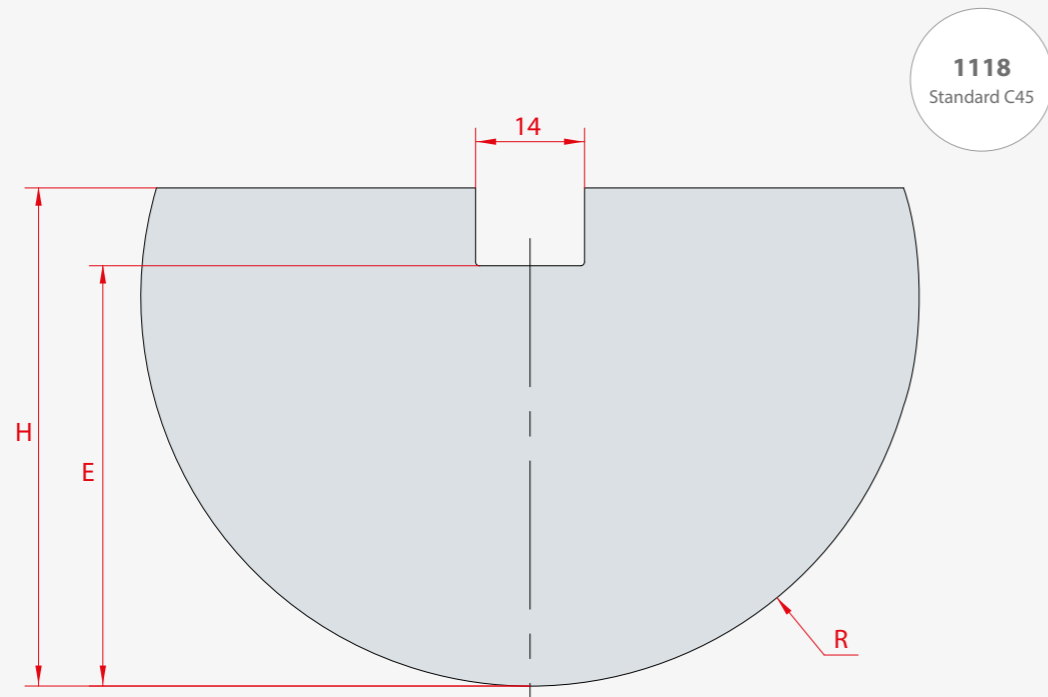

1118
Standard C45

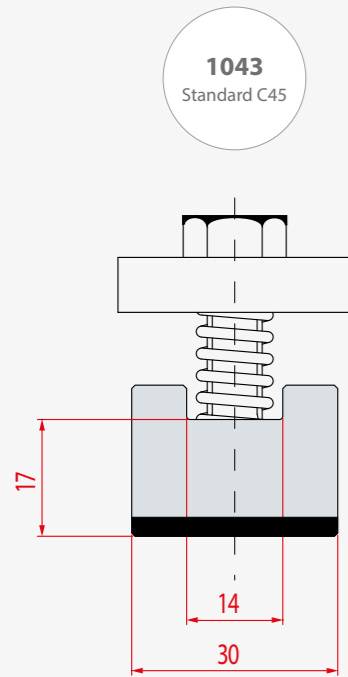

1043
Standard C45

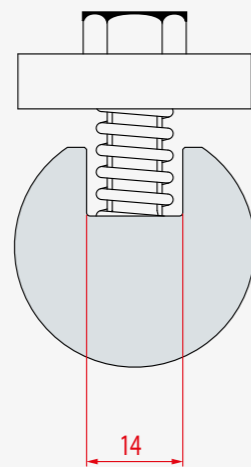

4274
Standard C45

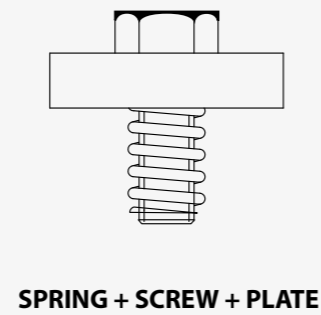

NYLON INSERTS AND HOLDERS

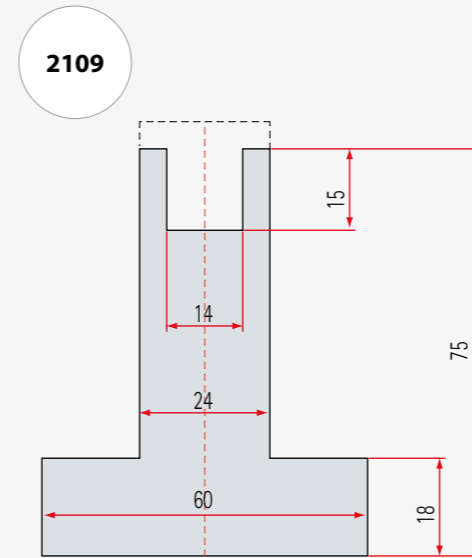

2109

2112			
A	V		
88°	6	8	10
60°	6	8	10
45°	6	8	10
30°	6	8	

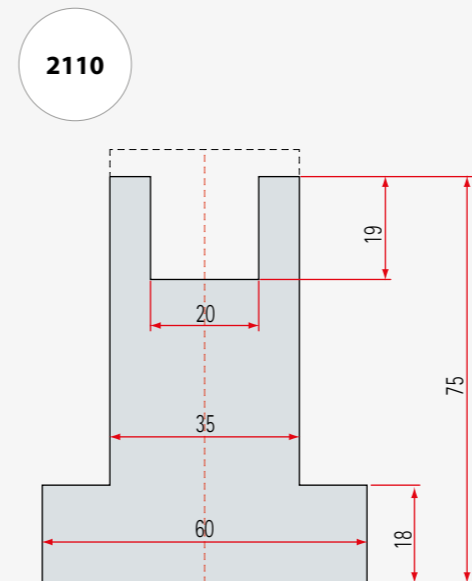
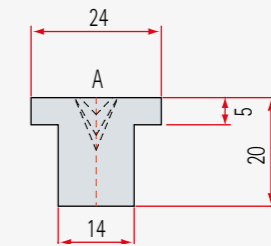

2110

2113					
A	V				
88°	6	8	10	12	16
60°	6	8	10	12	16
45°	6	8	10	12	
30°	6	8	10		

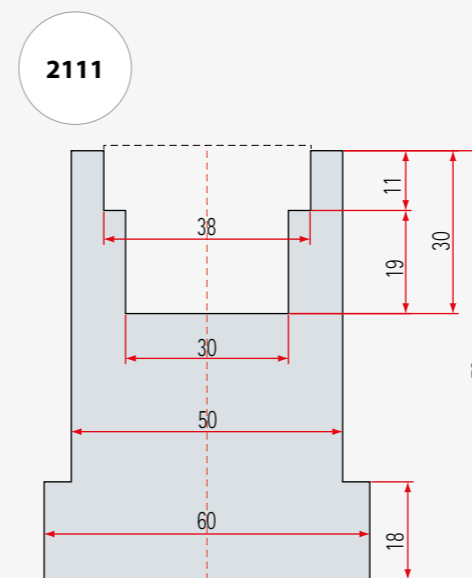
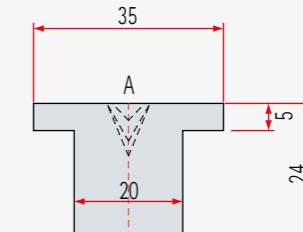

2111

2114							
A	V						
88°	6	8	10	12	16	20	25
60°	6	8	10	12	16	20	
45°	6	8	10	12	16	20	
30°	6	8	10	12	16		

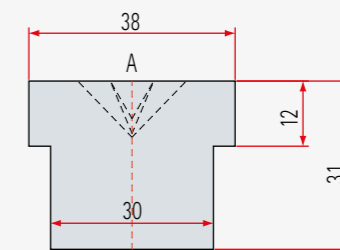

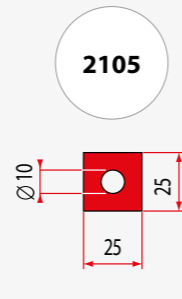
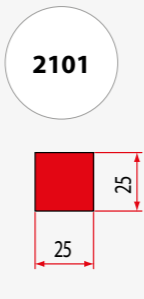
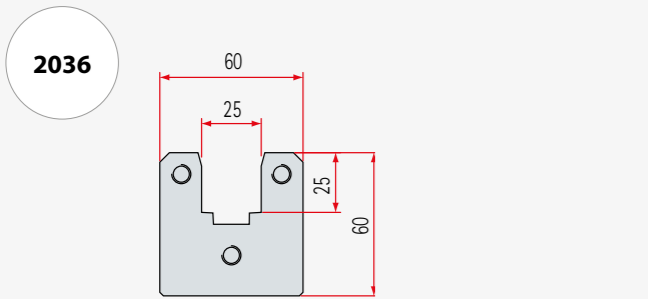

92 shore

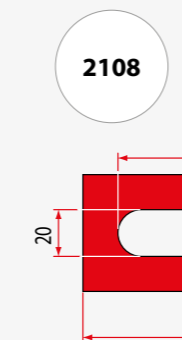
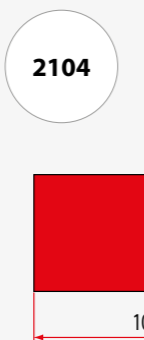
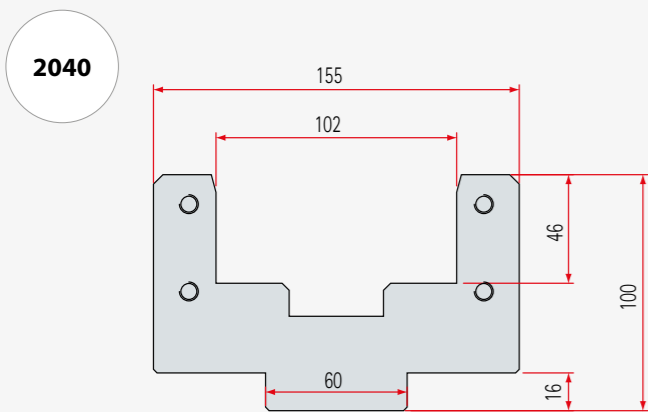
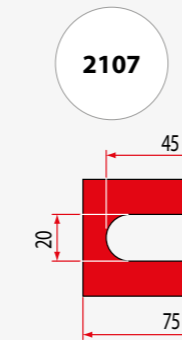
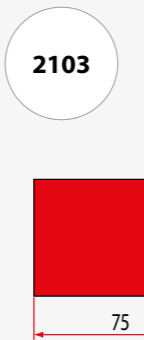
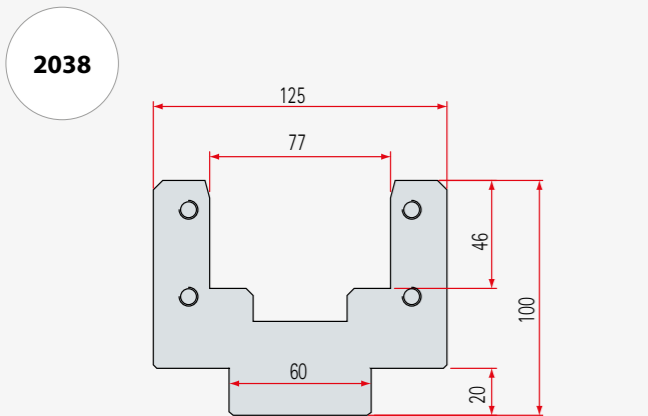
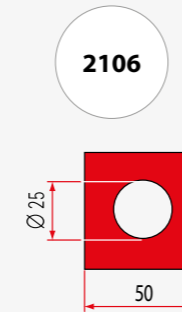
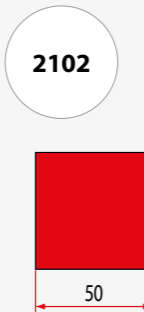
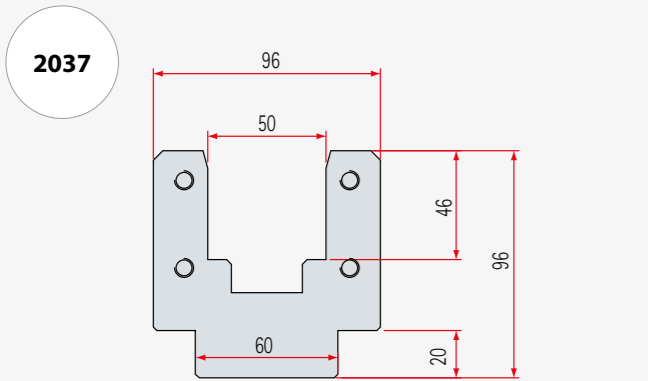

FOR ANY TYPE OF PRESS BRAKE

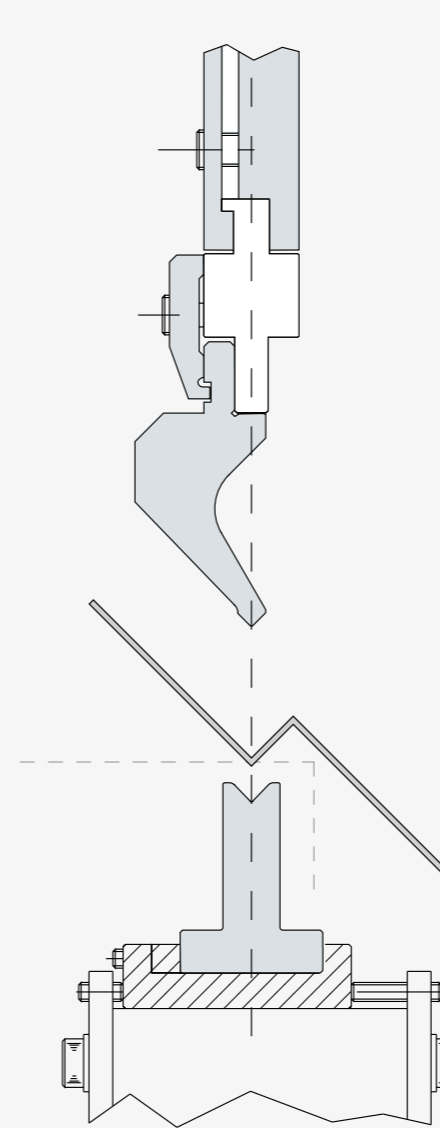

Minimum order n. 5 intermediates

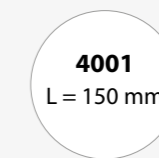

Please mark contact points and pressure points.

a =	1	2
b =		
c =		
d =		

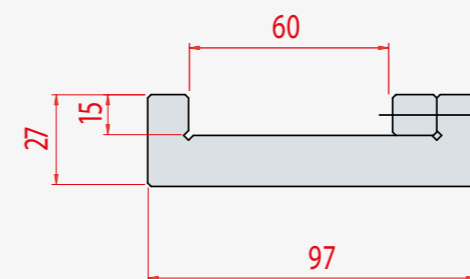
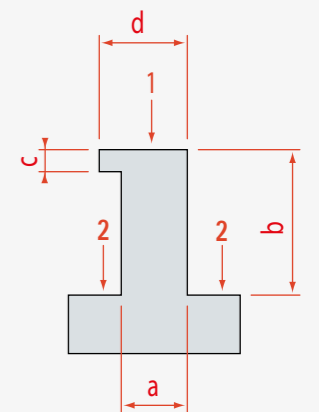

CODE	LENGTHS
9010	2100 mm
9011	2600 mm
9012	3100 mm
9013	4100 mm

TANGS ON REQUEST

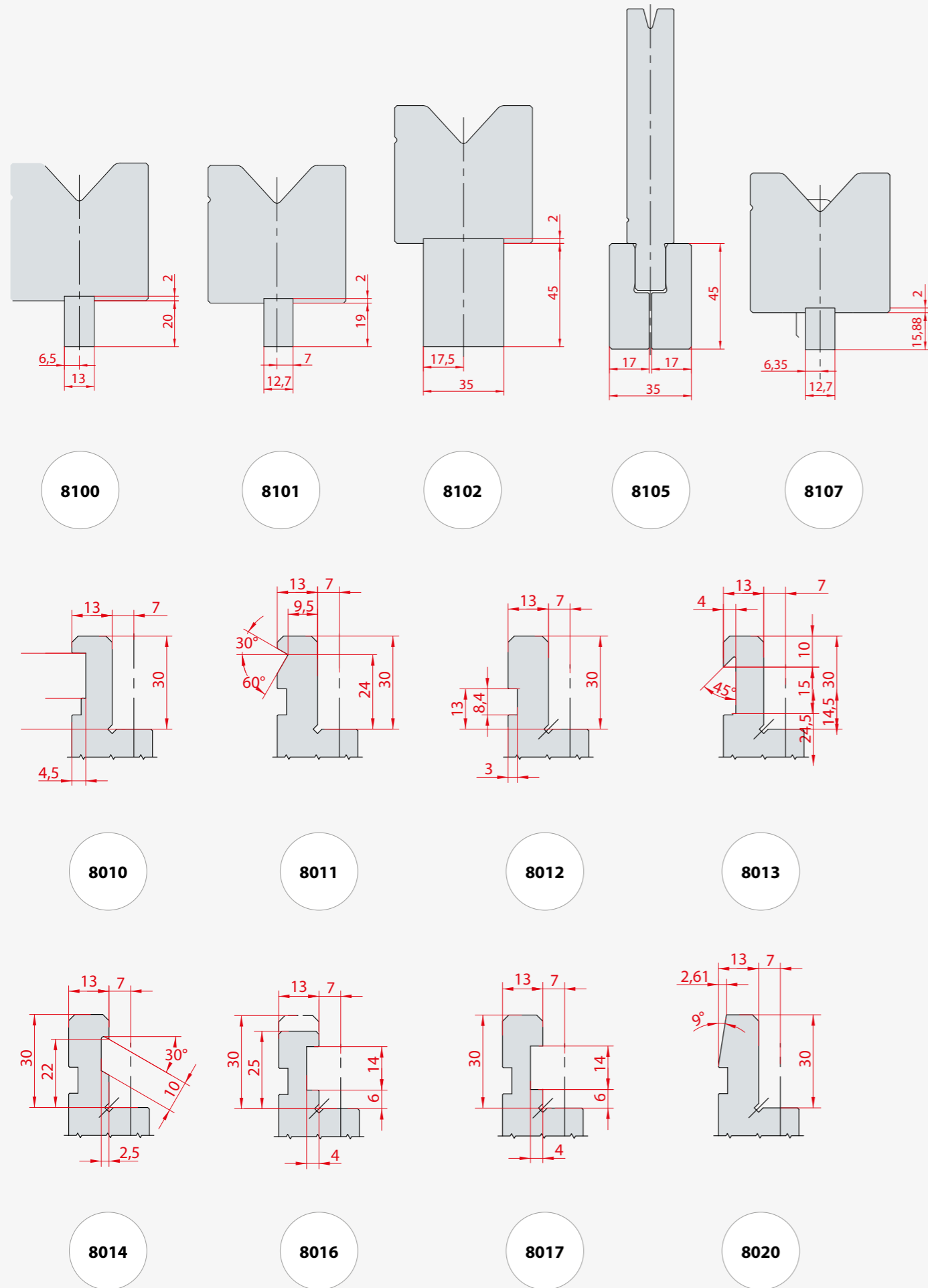

ADAPTORS

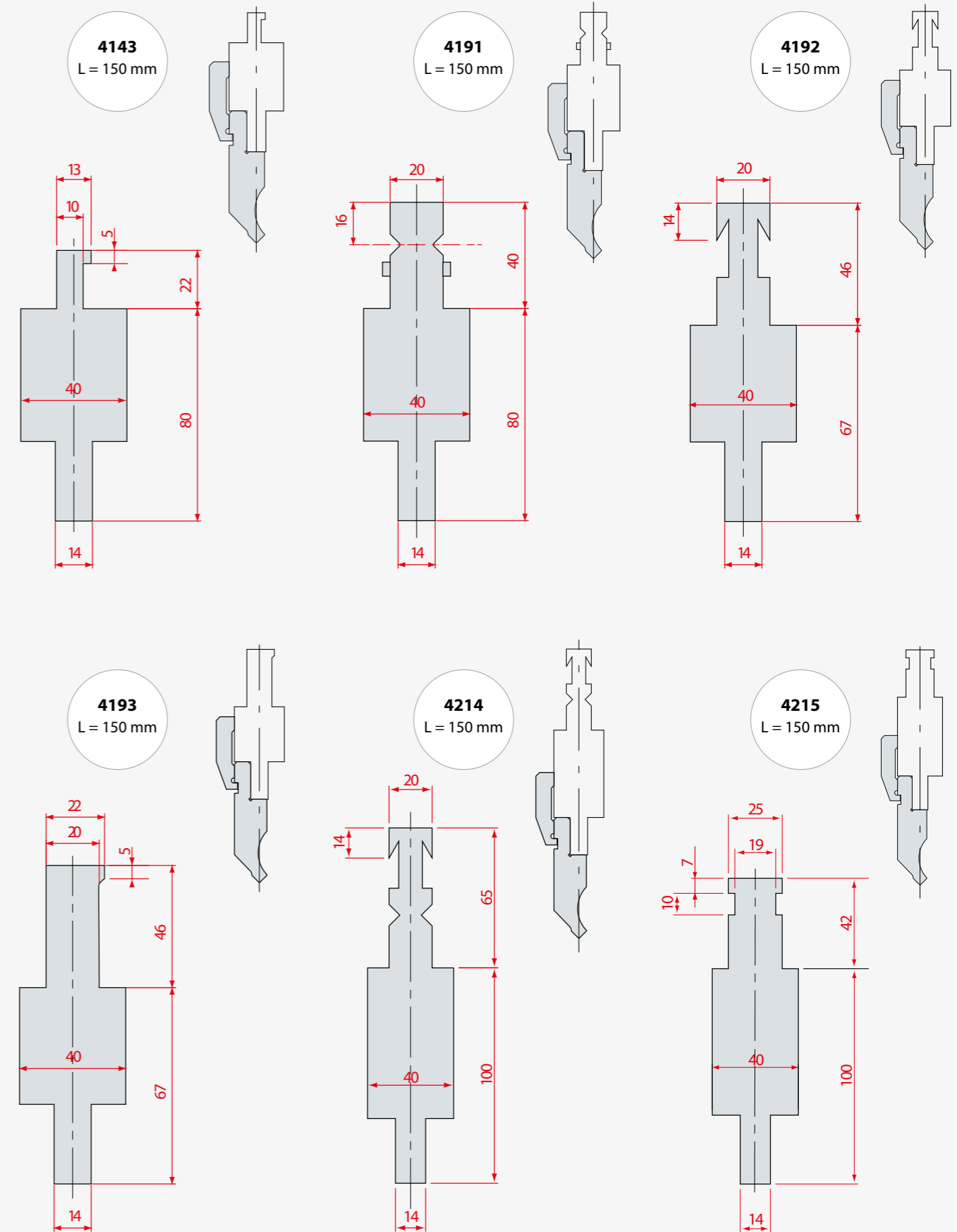

ADAPTORS

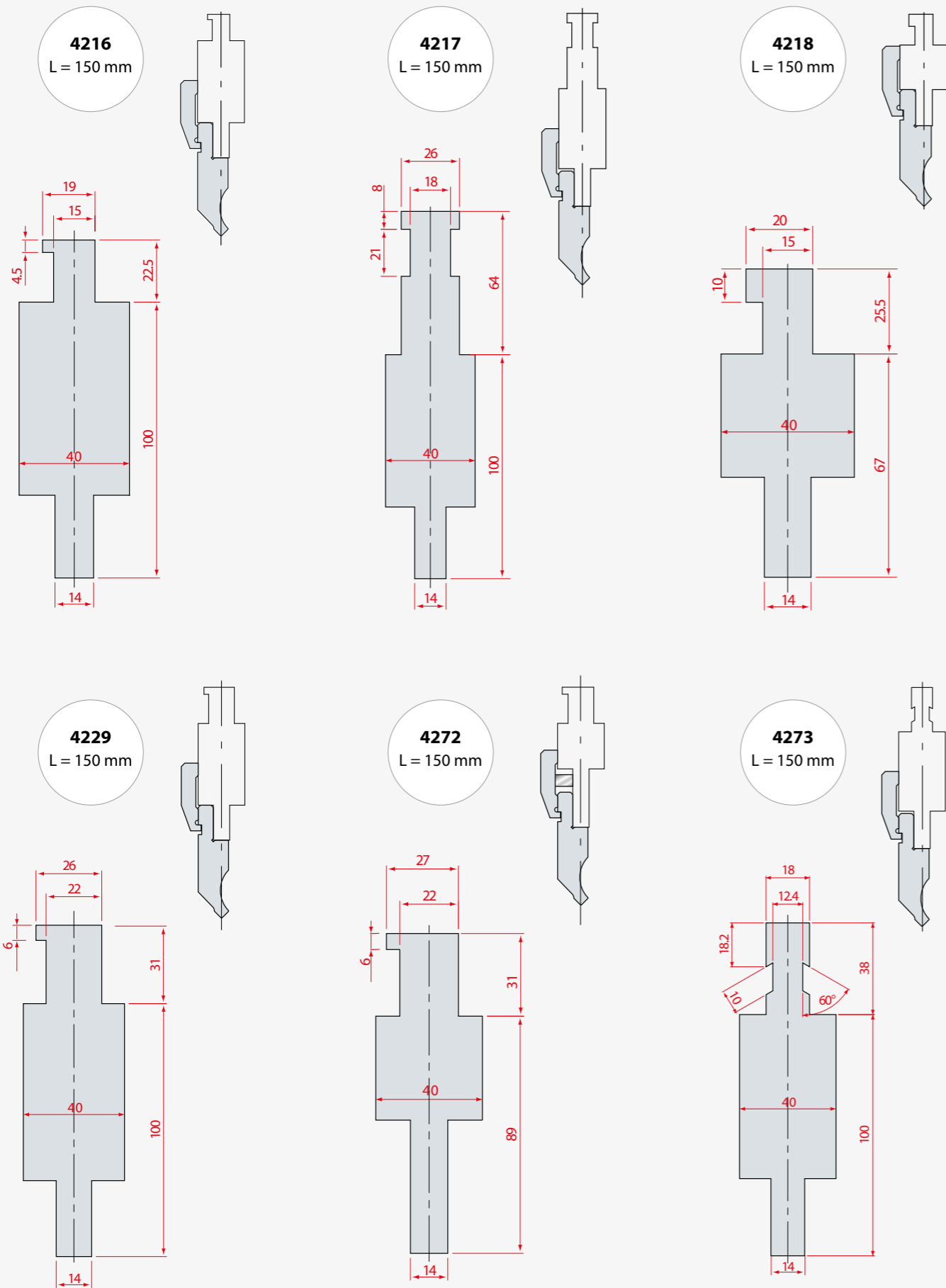

ADAPTORS

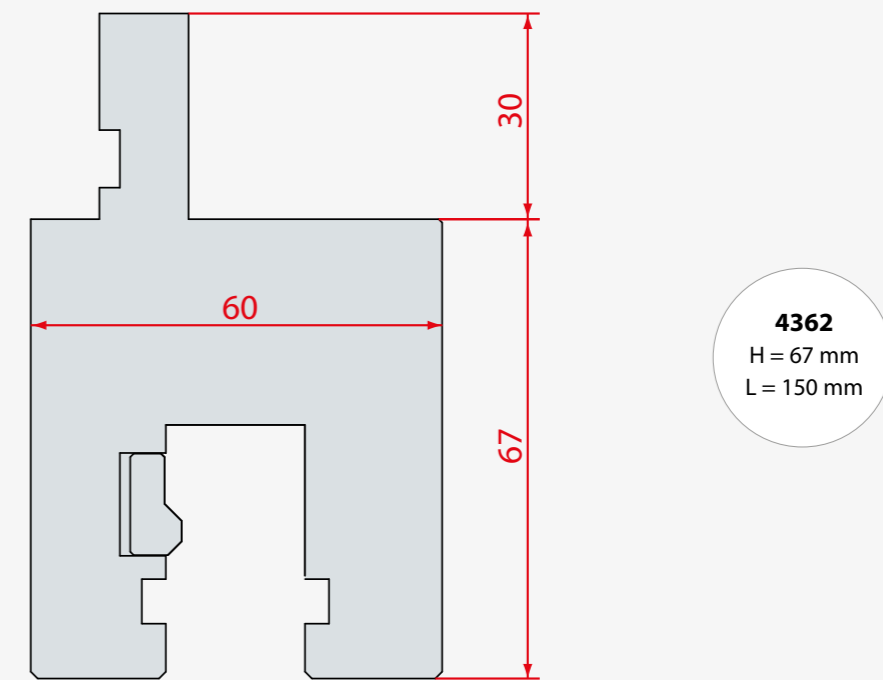

ES CLAMP PN

Patented and pneumatic intermediate es clamp pn model for promecam style tooling.

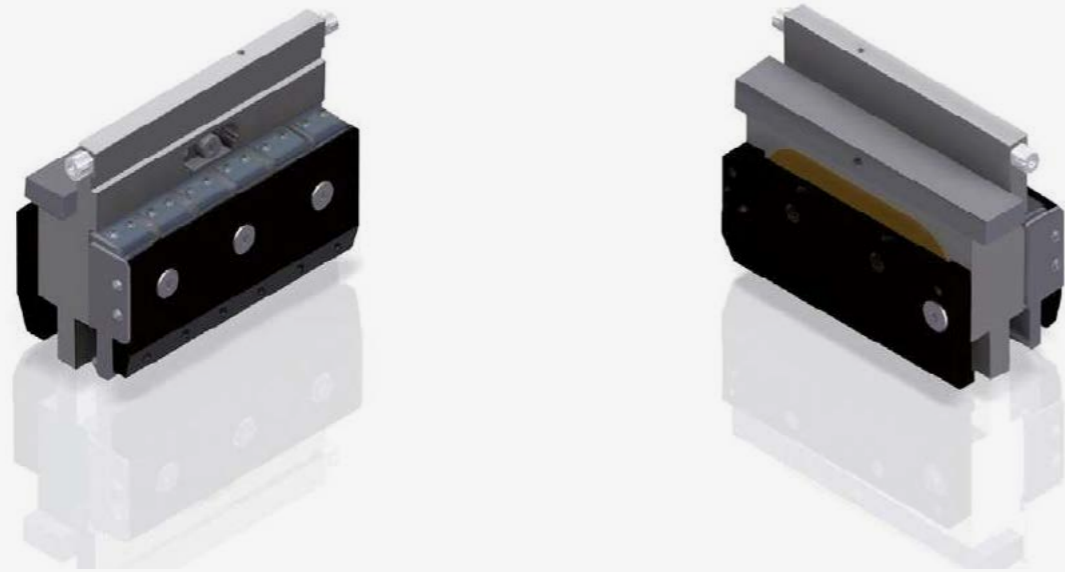

SPECIFICS

- Easy to install
- The system does not require any modification to the press brake or tooling
- Front insertion
- Fall-protection system
- Self-alignment of top tools
- Pneumatic clamping
- Possibility to remove the clamps easily
- Available in different heights
- Rear tool holder with manual closure included

CODE	HEIGHT (mm)
4369	110
4370	150
4371	200
4372	250
4373	300
4374	400
4375	500

OPTIONAL	
4376	Rear tool holder with pneumatic closure
4377	Pneumatic Kit

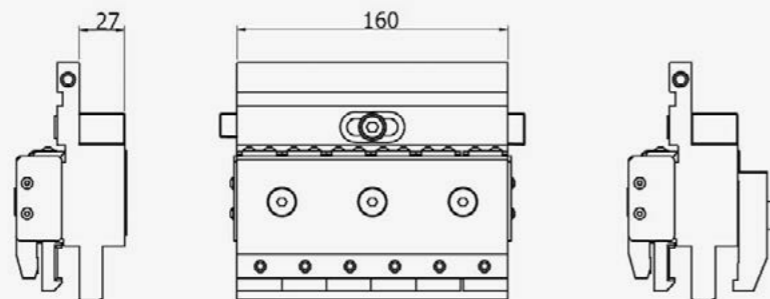

Subject to availability, intermediates could be provided :
 a) with a solid body and wedge
 b) as a bolted construction with a bolted tang and body

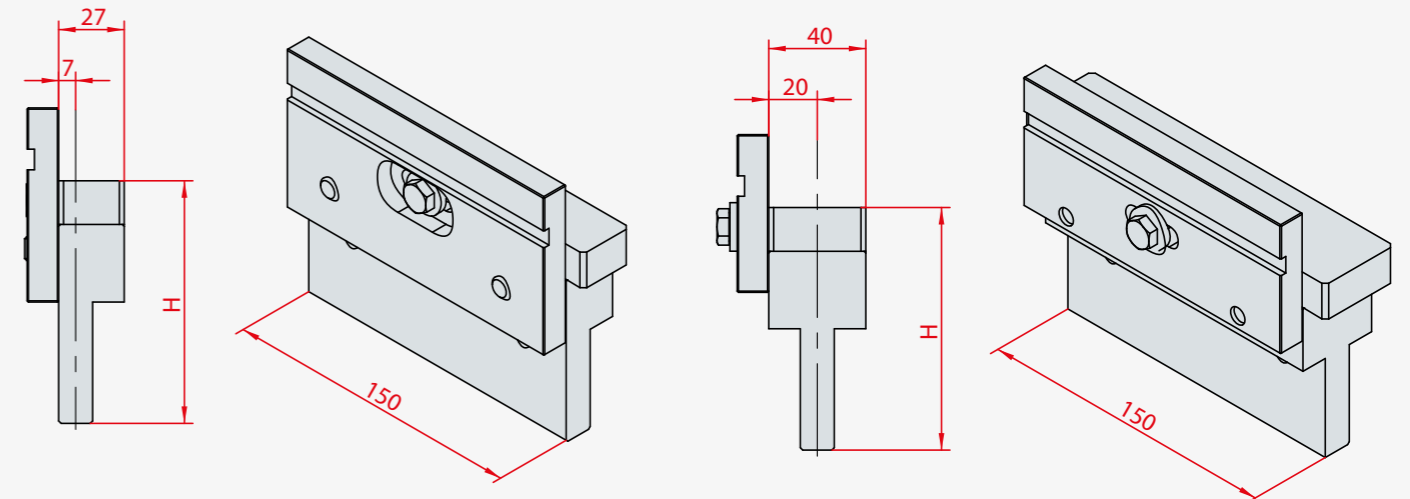

4221	H = 100 mm
4222	H = 120 mm
4223	H = 150 mm

4224	H = 100 mm
4225	H = 120 mm

FIXED INTERMEDIATES

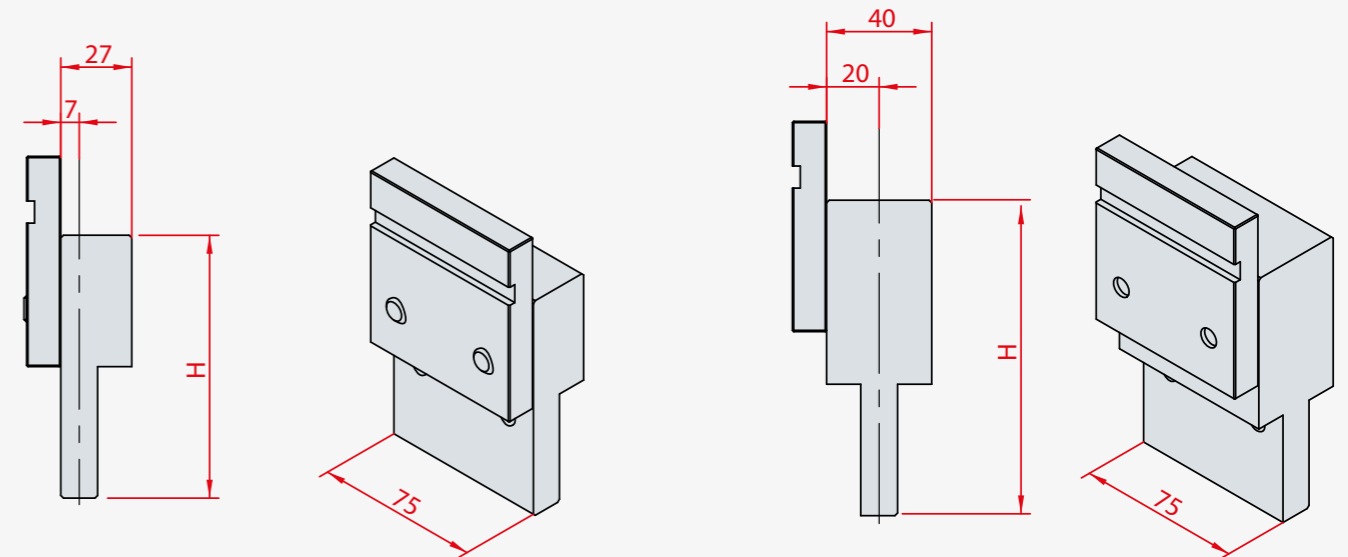

4226	H = 100 mm
4227	H = 150 mm

4228	H = 120 mm
-------------	------------

Screws included only with the purchase of the intermediates

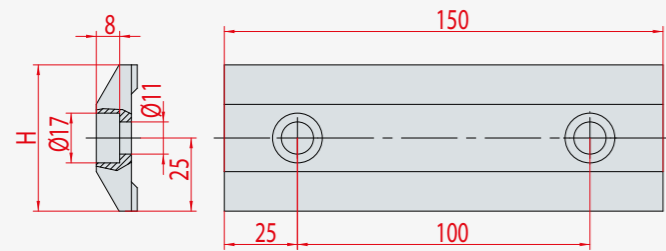

4016	H = 50 mm
5013	H = 43 mm

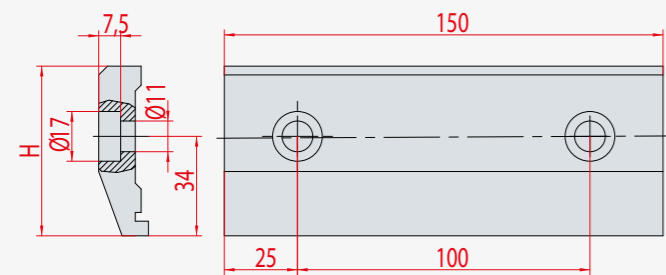

4020	H = 58 mm
5012	H = 52 mm

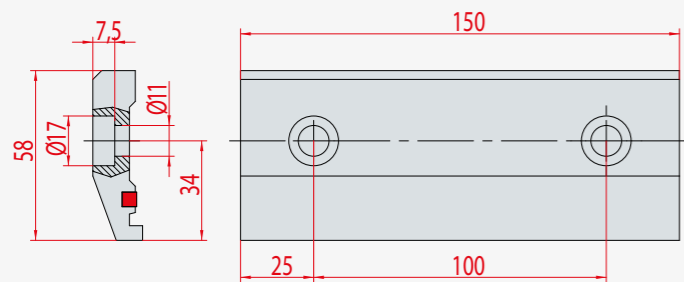

4199	H = 58 mm
-------------	-----------

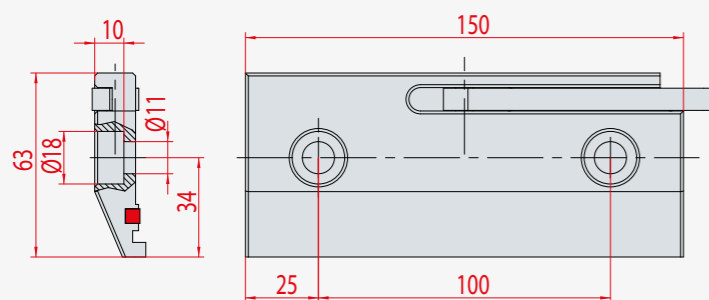

4220	H = 63 mm
-------------	-----------

Screws included only with the purchase of the intermediates

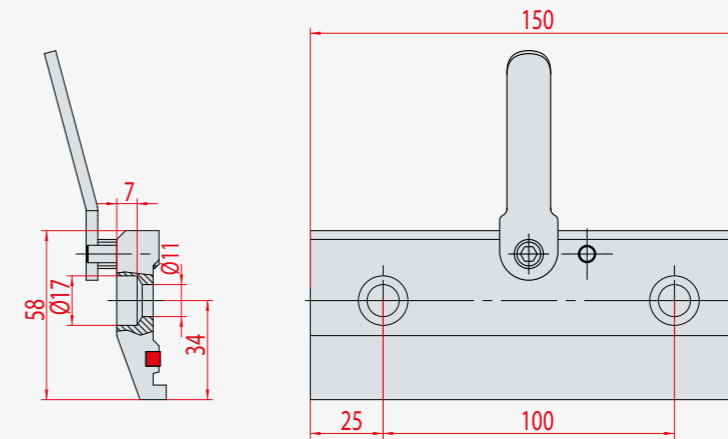

4219
H = 58 mm

4008
H = 50 mm

4090
H = 58 mm

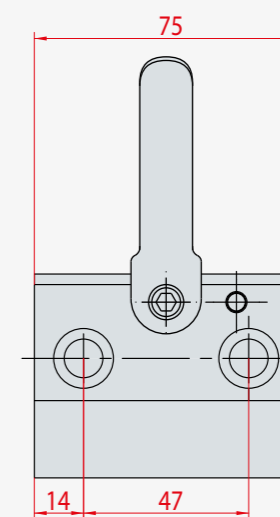
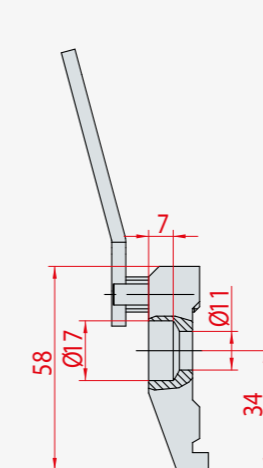
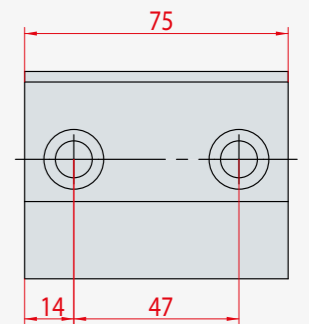
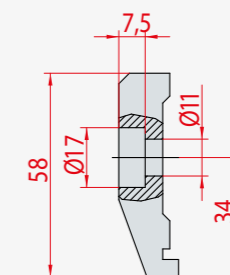
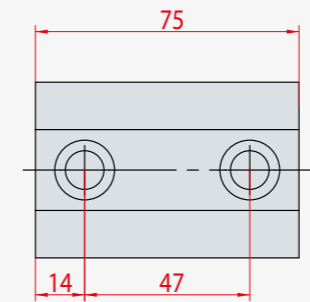
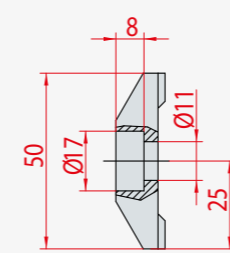

4007
H = 58 mm

CLAMPS

Screws included only with the purchase of the intermediates

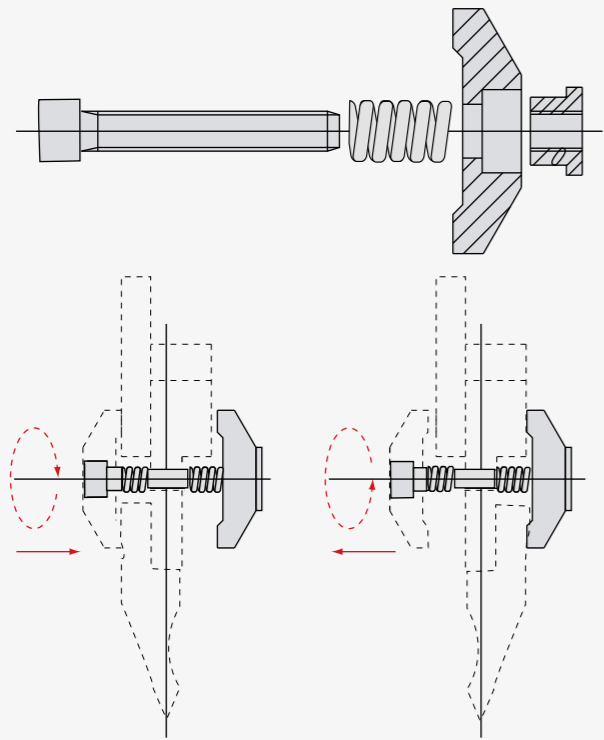

4031 Equipment for double clamping

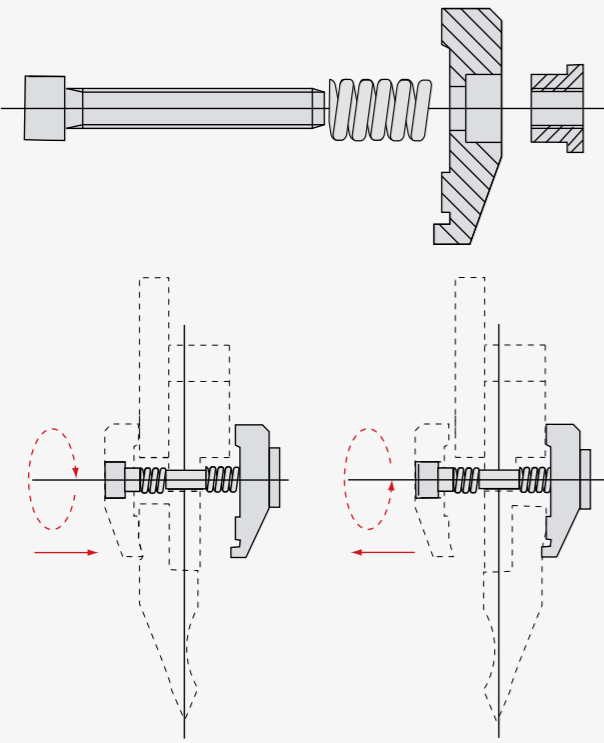

4032 Equipment for double clamping

LOWER ADAPTORS

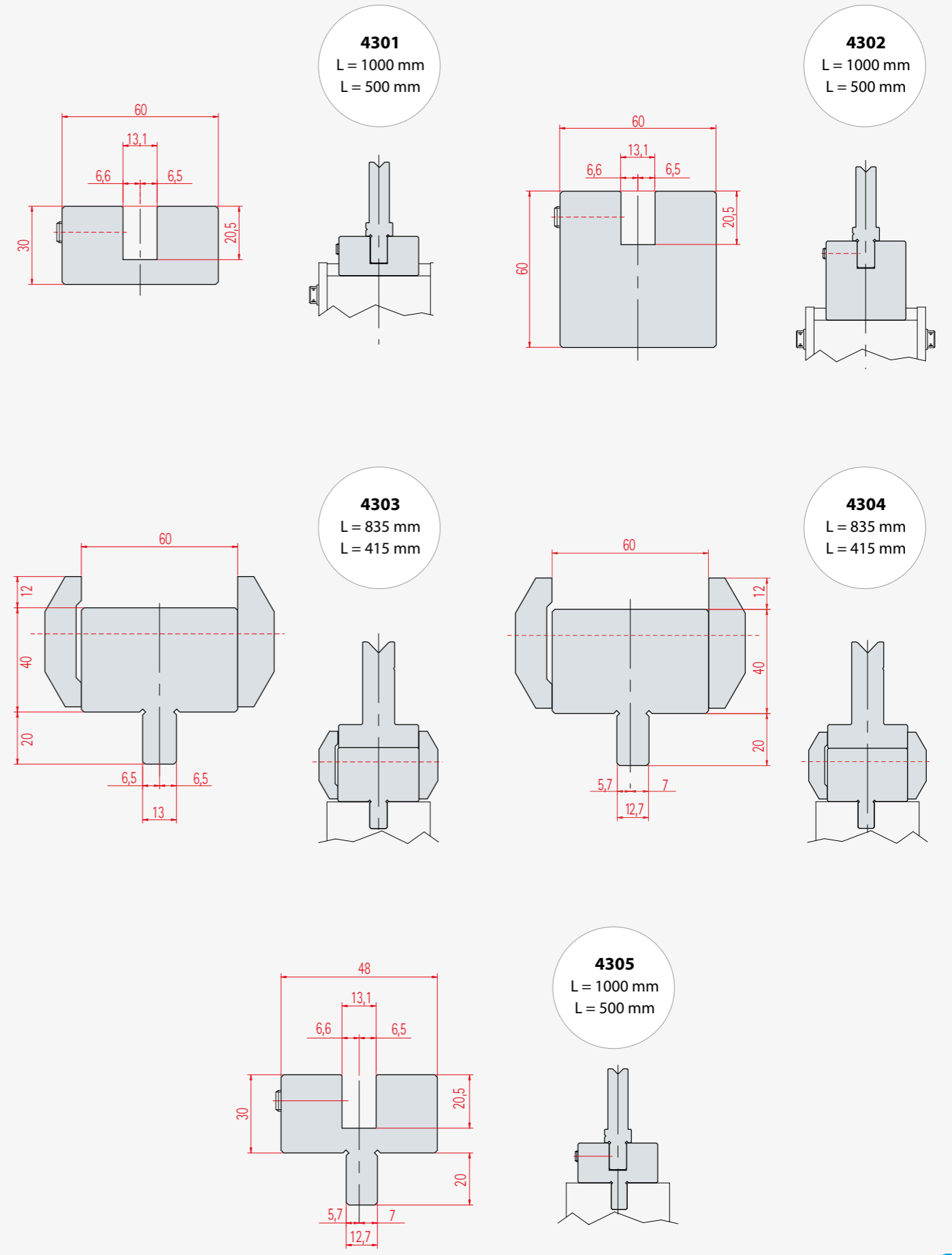

LOWER ADAPTORS

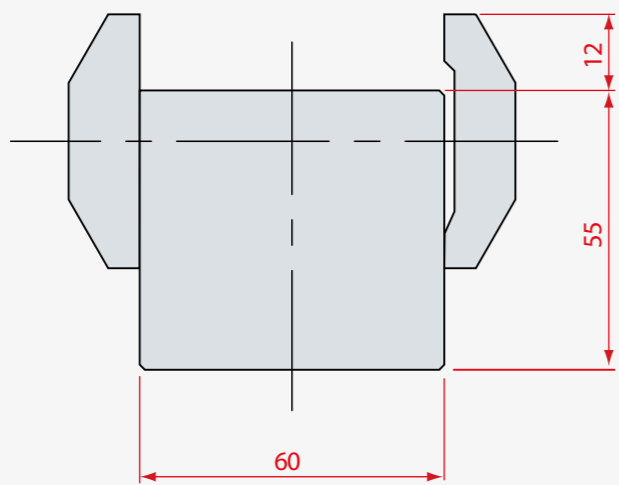
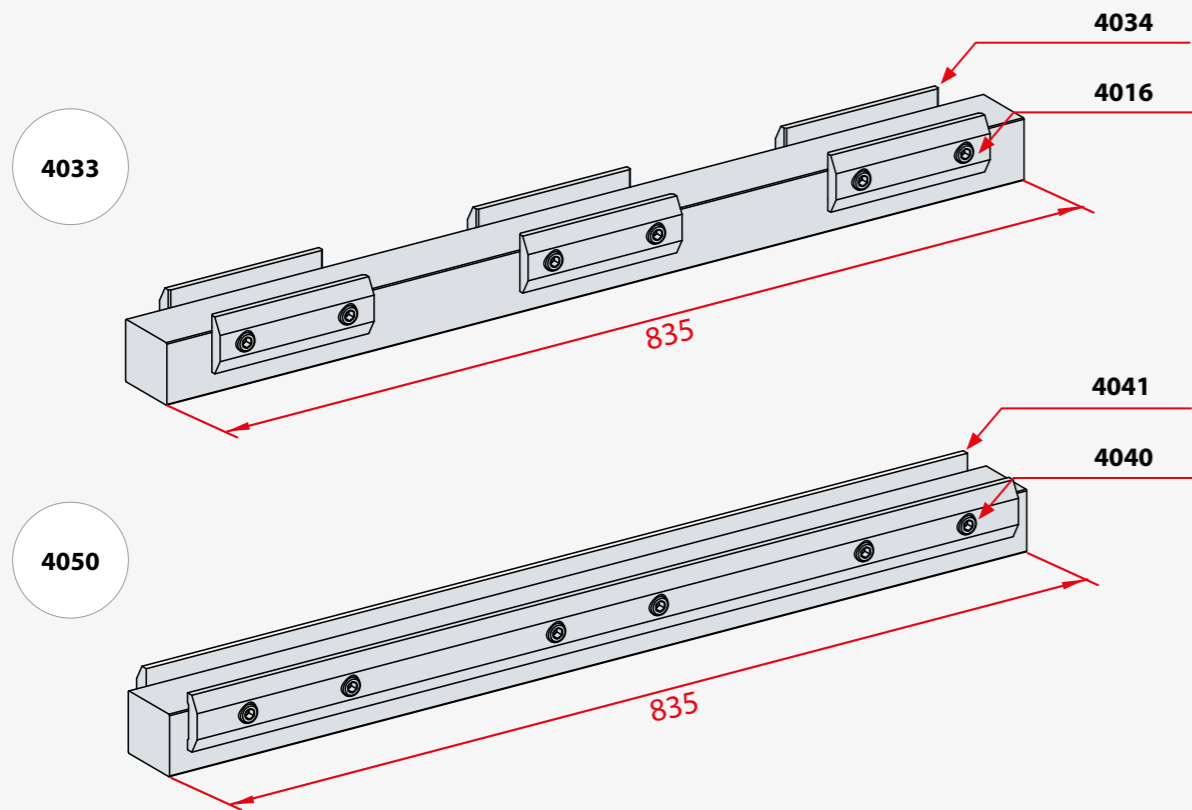

Lower adapter

4033
L = 835 mm

Lower adapter

4050
L = 835 mm

ACCESSORIES

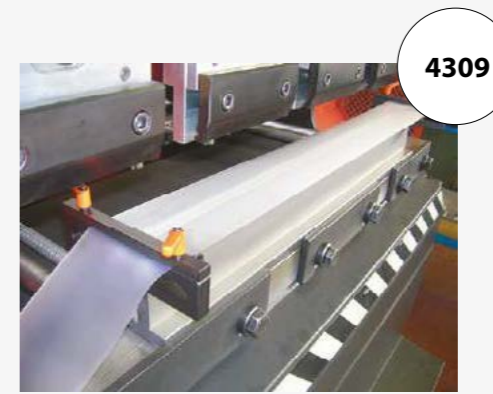

4309 COUPLE OF TIGHTENERS



FILM OF POLYURETHANE ANTISCRATCH 150 X 0,6 OF THICKNESS



MULTI V DIES ON REQUEST

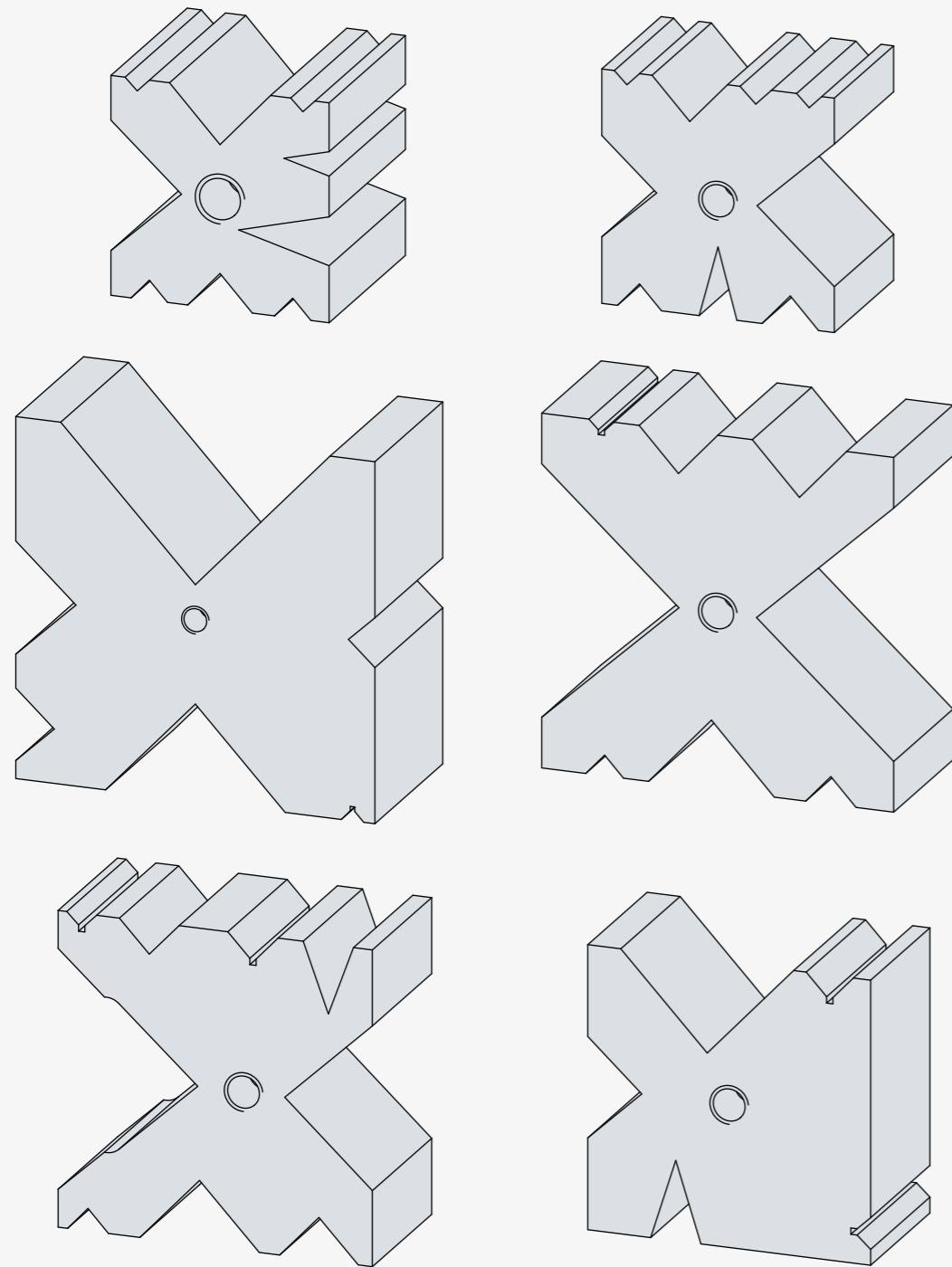

Material:

1.2312
C45
42CrM04

Working:

Hardened
Quenched-nitrided
Planed
Ground

Length (mm):

2000
3000
4000
6000
8000

SPECIAL TOOLS ON REQUEST

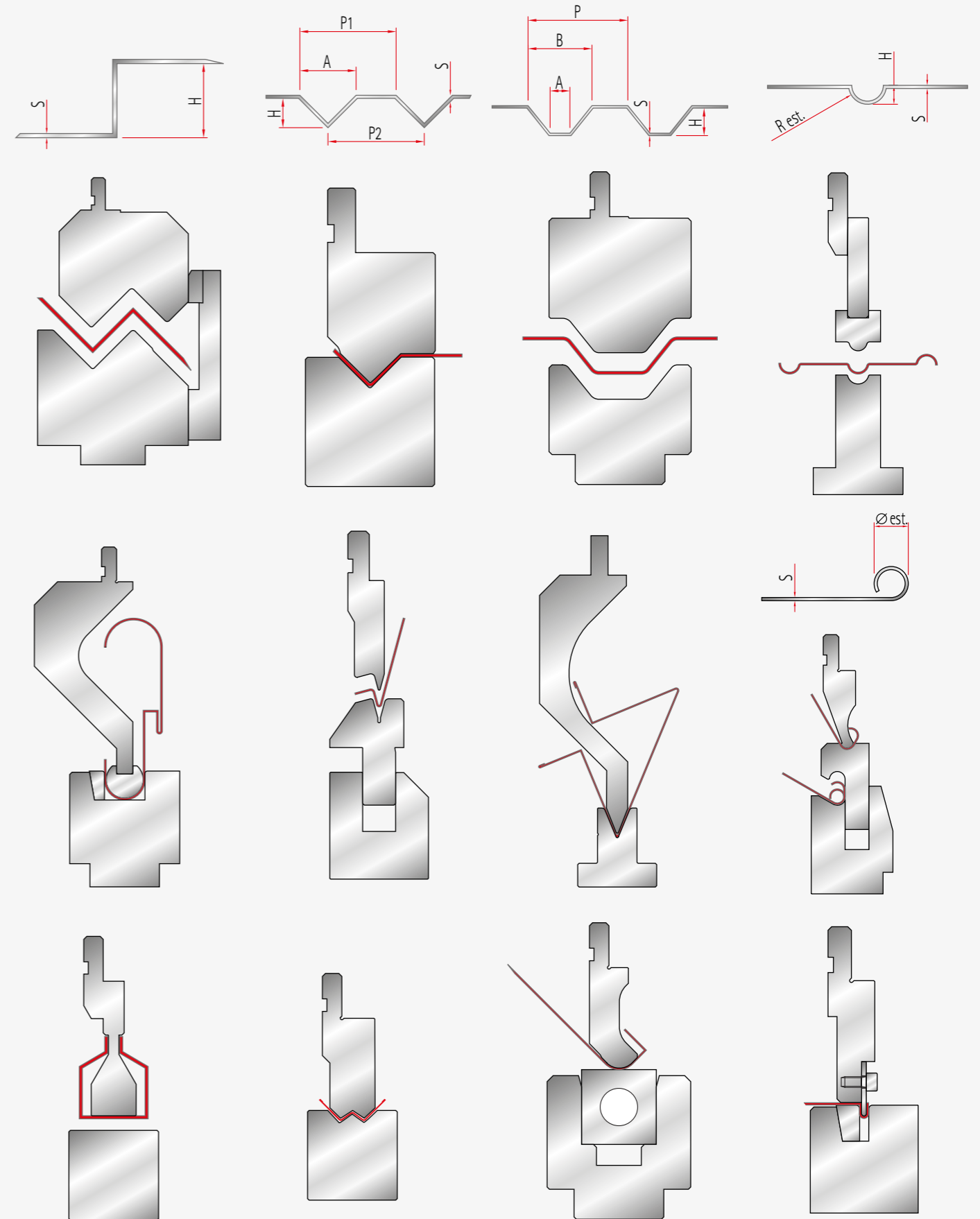



		ANGLE a							
		90	88	86	60	45	35	30	26
REQUEST RADIUS	1	0,08	0,09	0,09	0,2	0,32	0,47	0,57	0,69
	1,5	0,29	0,31	0,33	0,7	1,13	1,63	2	2,41
	2	0,5	0,53	0,56	1,2	1,94	2,79	3,44	
	2,5	0,7	0,75	0,79	1,7	2,74			
	3	0,91	0,97	1,03	2,2				
	3,5	1,12	1,19	1,26	2,7				
	4	1,33	1,41	1,49					
	4,5	1,53	1,63	1,73					
	5	1,74	1,85	1,96					
	5,5	1,95	2,07	2,19					
6	2,15	2,29	2,42						
STARTING RADIUS: 0.8									

BENDING / TONNAGE CHARTS

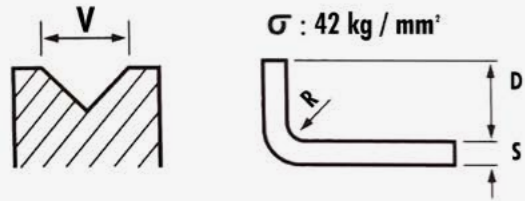

S mm	1	1.2	1.6	2	2.2	2.5	2.8	3	3.5	4	4.5	5	5.5	6	7	8	9	9.5	10	11	12	14	15.5	17	19	21	23	24.5	26	28	30	32	R	
3.6	4.8	6	7.3	8.6	9.6	11	12	13.5	15.5	17	18.5	21	23.5	27	30	33	36	39	42	48	53	59	64	71	76	82	88	94	106	111	118	D		
6	8	10	12	14	16	18	20	23	26	29	32	35	40	45	50	55	60	65	70	80	90	100	110	120	130	140	150	160	180	190	200	V		
0.5	2																																F	
0.8	7	5																																F
1.0	12	8	6																															F
1.2		12	9	7																														F
1.5			15	12	10	8																												F
2.0				23	19	16	14	12	10																									F
2.5					27	23	20	17	14	12	11																							F
3.0						30	25	22	19	17	15	13																						F
4.0							42	36	32	28	24	21	18																					F
5.0								54	47	40	34	30	26	24																				F
6.0									61	52	45	40	36	32	29																			F
7.0										74	64	57	51	46	42	35	30																	F
8.0											88	77	69	62	56	47	41	36	32															F
10												104	94	79	68	59	52	47	43	39													F	
12													121	103	90	79	71	64	58	54	50												F	
14														128	113	101	91	83	76	70	60	56											F	
16															137	123	112	102	94	81	76	71											F	
18																147	134	123	106	99	93													F
20																		135	126	118														F

- F (ton) Pressure in metric tons per meter
- V (mm) Groove on the die to fot sheet thickness
- D (mm) Minimum width of flange that can be bent
- R (mm) Inside Radius
- S (mm) Sheet thickness



SELMACHTM

MACHINERY

The UK's #1 for metalworking machines, delivering unmatched quality and service

Need machinery? Call 01432 346 579 now!



MORGAN RUSHWORTH
SINCE 1872

KNOWLEDGE BASE ARTICLES - TOOLING SPECIFIC

Selecting and maintaining the right tooling for your press brake is crucial to achieving precision and efficiency in your metalworking processes. With a wide variety of punches, dies, and other tooling options available, understanding their uses and how to optimise their setup can make a significant difference in your results.

This section brings together a range of articles to help you get the most out of your press brake tooling. From guides on calculating tonnage and V-sizes to tips for aligning tools and setting laser guards, these resources offer clear, practical advice. Whether you're exploring bespoke tooling options or looking to refine your processes, you'll find valuable insights here to support your work.

UNLOCK EVERYTHING YOU NEED TO KNOW BELOW!



SELMACH
MACHINERY

Press Brake Toolings, A Guide to Punches and Dies

KNOWLEDGE BASE VIDEO



SELMACH
MACHINERY

Curl Tooling on a Press Brake

KNOWLEDGE BASE VIDEO



SELMACH
MACHINERY

How to work out V Sizes and Tonnage for your Press Brake FAQ

KNOWLEDGE BASE VIDEO



SELMACH
MACHINERY

How to work out the tonnage on a Press Brake FAQ

KNOWLEDGE BASE VIDEO



SELMACH
MACHINERY

How to set up your Press Brake Tool Alignment Correctly FAQ

KNOWLEDGE BASE VIDEO



SELMACH
MACHINERY

How to Set the Laser Guards On Your Press Brake After You Have Changed Your Top Tooling

KNOWLEDGE BASE VIDEO

MAINTENANCE - PRESS BRAKE ARTICLES

Keeping your CNC press brake in optimal condition is key to ensuring reliable performance and prolonging its lifespan. Routine maintenance not only helps to prevent unexpected issues but also ensures your machine operates with precision and consistency. Whether it's general upkeep or specific adjustments, understanding your press brake's requirements can make a significant difference to its efficiency.

In this section, you'll find a range of resources focused on press brake maintenance. From general maintenance tips to detailed guides on referencing and parking CNC press brakes using ESA controls, as well as adjusting backgauge and Y-axis settings, these articles offer practical advice to help you maintain and optimise your machine. Explore the links below to find step-by-step instructions and expert insights.

UNLOCK EVERYTHING YOU NEED TO KNOW BELOW!



SELMACH
MACHINERY

How to Maintain Your Press Brake FAQ

KNOWLEDGE BASE VIDEO



SELMACH
MACHINERY

Press brake turned off with the beam left in up position

KNOWLEDGE BASE VIDEO



SELMACH
MACHINERY

How to Correct Y1, Y2 and X on your Press Brake FAQ

KNOWLEDGE BASE VIDEO



SELMACH
MACHINERY

How to Adjust the Backgauge, Datum & Probe Settings on Press Brake Machines FAQ

KNOWLEDGE BASE VIDEO



SELMACH
MACHINERY

How to adjust the reference for Y1 and Y2 on the Press Brake Machine FAQ

KNOWLEDGE BASE VIDEO



SELMACH
MACHINERY

Referencing of CNC Press Brakes when switched off with beam up

KNOWLEDGE BASE VIDEO



**Selmach Machinery Ltd,
Technology Centre,
Unit 8 Beacon Road,
Rotherwas Industrial Estate,
Hereford HR2 6JF**

**01432 346 579
www.selmach.com**