



PBS CNC Pressbrakes

The Morgan Rushworth PBS CNC range of hydraulic pressbrakes are available in 3 or 4 axis configuration and are fitted as standard with the ESA S640 CNC controller which includes offline software to enable the programming of parts from an office PC. Multi bend operations with complex forms can therefore be effectively managed, reducing operator error and reducing production times. The Y1 and Y2 axis are fully synchronised and accurate to 0.01mm with proportional valve technology while the mono block welded steel frame ensures minimum deflection under maximum load. The AKAS laser tooling guards allow safe but easy handling of components resulting in enhanced operator experience and increased productivity.



PBS CNC Range



**ESA S640
CNC
CONTROL**

**OPTIONAL ESA
S660 TOUCH
SCREEN CNC
CONTROL**





X AXIS CNC BACKGAUGE

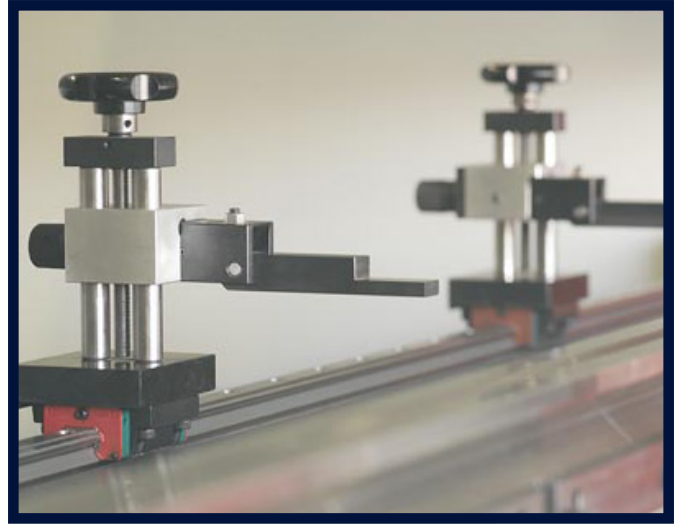

X AXIS BACKGAUGE FINGERS



OPTIONAL X+R AXIS CNC BACKGAUGE

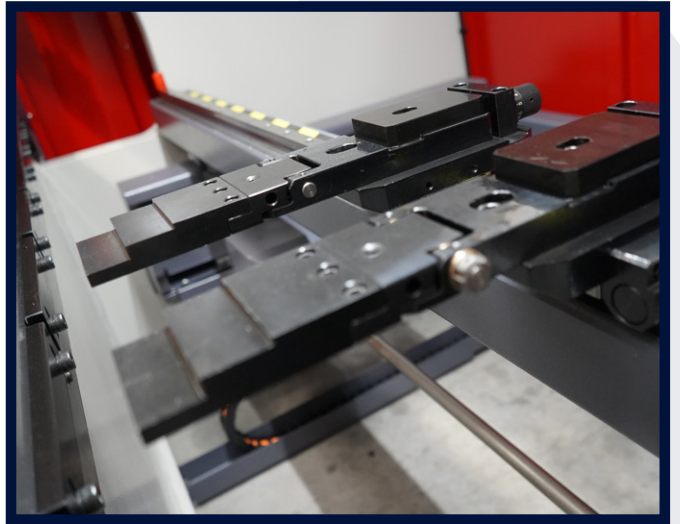

OPTIONAL X+R AXIS BACKGAUGE FINGERS

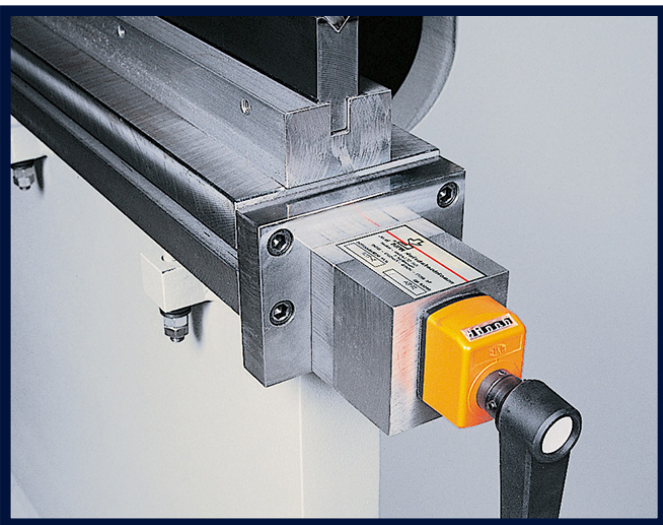

OPTIONAL MANUAL BOTTOM TOOL CROWNING SYSTEM



CNC CONTROLLED BOTTOM TOOL CROWNING SYSTEM (OPTIONAL)

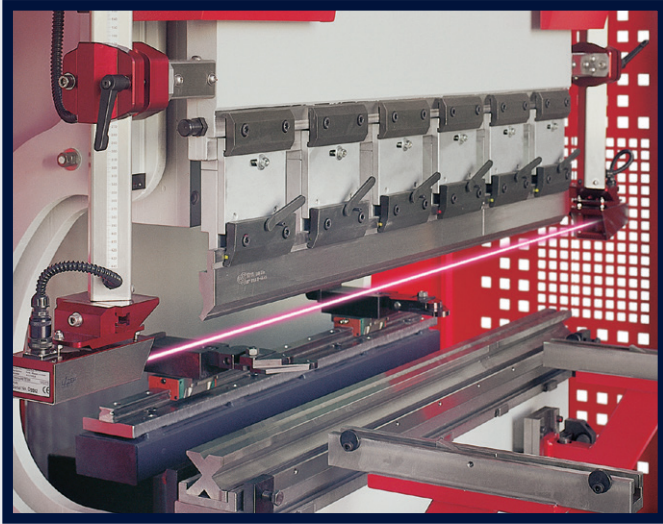

FRONT LASER PROTECTION SYSTEM

Machine Features

- User friendly ESA S640 control on pendant arm with 2D graphical view, auto bend sequence calculations and large tool library
- 2D graphical programming software for office based PC
- Ideal for complex multi bending operations, especially where volume production with accurate repeatability is required
- Fully synchronised CNC control for left and right upper beam cylinder position - Y1 + Y2 axis
- CNC control for backgauge depth - X axis.
- Manual adjustment of backgauge height - R axis
- Manual side to side adjustment of backgauge fingers - Z axis
- AKAS laser tooling guards for enhanced ease of use
- Euro style top clamps with intermediates and quick release tool clamps
- Sectionalised goose neck top tool and multi vee bottom die
- Strong rigid welded mono block frame able to withstand deflection under maximum load
- Hydraulic ram travel guided in low friction slideways
- Large open height and generous ram stroke
- Deep reinforced throat in side frames
- Front support arms with flip stop adjustable on a linear rail
- Dual foot switch console with emergency stop

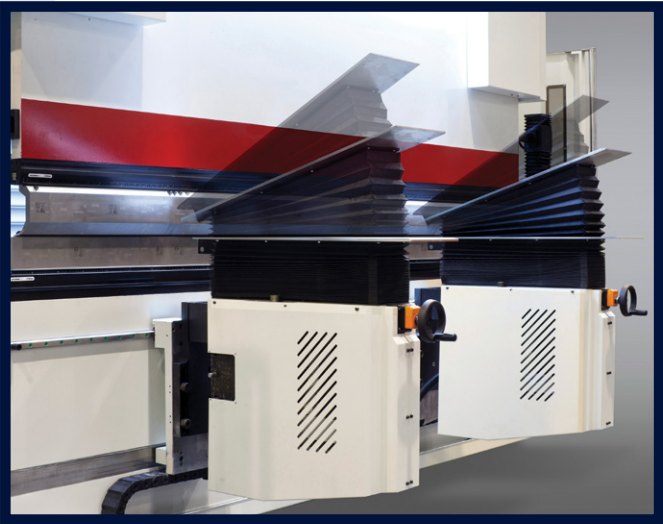

**SHEET FOLLOWER SUPPORT ARMS
(OPTIONAL)**

Optional Equipment

- CNC control for backgauge height - R axis
- Manual bottom tool crowning system
- CNC controlled bottom tool crowning system
- Quick release top tool clamping system
- ESA S875 Touch Screen 2D/3D graphical CNC control
- Additional backgauge fingers
- Additional front support arms

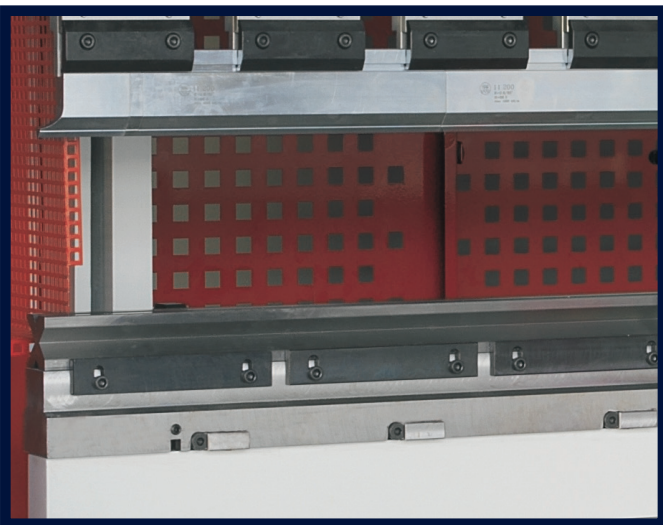

EURO STYLE TOOLING



**QUICK RELEASE TOP TOOLING
(OPTIONAL)**

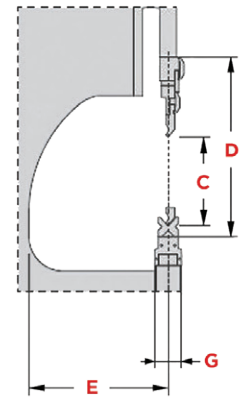
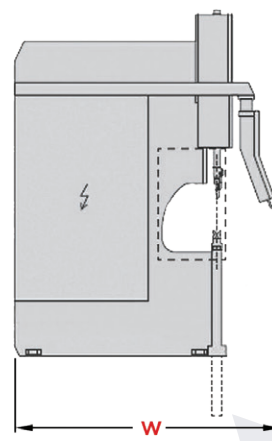
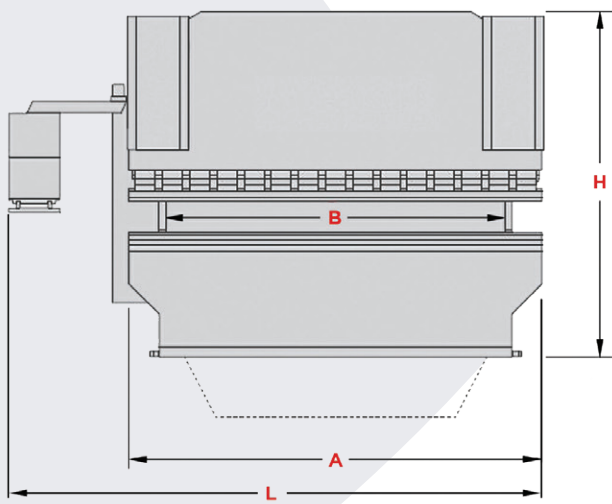

WATCH THE
MACHINE IN
ACTION



TECHNICAL SPECIFICATIONS

MODEL	STOCK CODE	Tonne	BENDING POWER A mm	BENDING LENGTH B mm	DIST. BETWEEN COLUMN mm/sec	Y RAPID SPEED mm/sec	Y WORKING SPEED mm/sec	Y RETURN SPEED mm	TRAVEL IN X AXIS mm/sec	SPEED OF X AXIS mm	TRAVEL IN R AXIS (OPTIONAL) mm/sec	SPEED OF R AXIS (OPTIONAL) mm/sec	NUMBER OF BACKGUAGE FINGERS	NUMBER OF SHEET SUPPORT ARMS	OIL CAPACITY Litre	MOTOR POWER kW	STROKE C mm	DAYLIGHT D mm	THROAT DEPTH E mm	TABLE HEIGHT F mm	TABLE WIDTH G mm	LENGTH L mm	WIDTH W mm	HEIGHT H mm	WEIGHT kg
PBS CNC 1250/40	M5042	40	1250	1070	100	10	100	1000	350	160	240	2	2	80	8	215	455	410	800	60	3000	2670	2250	3300	
PBS CNC 2100/60	M5043	60	2100	1600	90	9.4	80	1000	350	160	240	2	2	140	9.5	210	475	410	880	60	3850	2780	2542	5400	
PBS CNC 2600/60	M5044	60	2600	2050	100	9.4	80	1000	350	160	240	2	2	140	9.5	210	475	410	880	60	4350	2780	2542	6200	
PBS CNC 2600/90	M5045	90	2600	2050	90	9.4	80	1000	350	160	240	2	2	140	11.5	260	530	410	890	60	4350	2780	2605	7100	
PBS CNC 3100/90	M5046	90	3100	2550	100	9.4	80	1000	350	160	240	2	2	140	11.5	260	530	410	880	60	4850	2790	2605	7900	
PBS CNC 3100/120	M5047	120	3100	2550	100	9.6	80	1000	350	160	240	2	2	140	15	260	530	410	890	60	4850	2790	2605	8400	
PBS CNC 3100/160	M5048	160	3100	2550	100	7.7	80	1000	350	160	240	2	2	210	19	260	530	410	890	60	4850	2800	2905	9700	
PBS CNC 3100/200	M5049	200	3100	2550	100	7.7	80	1000	350	160	240	2	2	210	22.5	260	530	410	880	60	4850	2800	2905	10000	
PBS CNC 3100/240	M5050	240	3100	2550	90	7.6	80	1000	350	160	240	2	2	210	26	260	530	410	880	60	4850	2810	2905	11000	
PBS CNC 3100/300	M5051	300	3100	2550	90	9.1	80	1000	350	160	240	2	2	280	26	320	660	500	905	280	4850	3015	2905	15000	
PBS CNC 3700/120	M5052	120	3700	3250	100	9.6	80	1000	350	160	240	2	2	210	15	260	530	410	870	60	5450	2830	3150	11000	
PBS CNC 3700/160	M5053	160	3700	3250	100	7.7	80	1000	350	160	240	2	2	210	19	260	530	410	880	60	5450	2800	2905	11500	
PBS CNC 3700/200	M5054	200	3700	3250	100	7.7	80	1000	350	160	240	2	2	210	22.5	260	530	410	880	60	5450	2800	2905	12000	
PBS CNC 3700/240	M5055	240	3700	3250	90	7.6	80	1000	350	160	240	2	2	210	26	260	530	410	880	60	5450	2810	2905	13500	
PBS CNC 3700/300	M5056	300	3700	3250	90	9.1	80	1000	350	160	240	2	2	280	26	320	660	500	980	280	5450	3020	3200	17000	
PBS CNC 4100/160	M5057	160	4100	3550	100	7.7	80	1000	350	160	240	2	2	210	19	260	530	410	880	60	5850	2800	2905	12000	
PBS CNC 4100/200	M5058	200	4100	3550	100	7.7	80	1000	350	160	240	2	2	210	22.5	260	530	410	880	60	5850	2800	2905	12500	
PBS CNC 4100/240	M5059	240	4100	3550	90	7.6	80	1000	350	160	240	2	2	210	26	260	530	410	880	60	5850	2810	2905	14000	
PBS CNC 4100/300	M5060	300	4100	3550	90	9.1	80	1000	350	160	240	2	2	280	26	320	660	500	980	280	5850	3020	3200	18500	