

BIANCO

Bianco SA R Semi Automatic Bandsaws

Bianco have been manufacturing bandsaws in Italy for over thirty years and have built a reputation for producing precise, reliable, and accurate machines. All machines have modern cast bows from special alloys to ensure one of the highest precision bandsaw ranges available.

The Bianco SA R Semi Automatic Double Mitre Bandsaws 415v are esteemed for their reliability, dependability and high accuracy which are hallmarks of Bianco Bandsaws.



Bianco
420 SA R (High Controller Position)

Machine Features

- Turntable double mitring system
- Hydraulic cutting with variable pressure and variable speed (Semi-Automatic)
- Sliding Hydraulic vice
- Fast approach with auto bow height return setting
- Quick mitring swivel head up to 60°
- Cast bow construction
- Swarf brush
- Carbide blade guides for high accuracy
- 2 speed motor
- Heavy duty & fast cutting
- Coolant System
- Blade tension indicator
- Safety interlock switch fitted to band wheel cover
- Material length stop
- High controller position

Optional Equipment

- Low controller position
- Blade speed variation
- Spray mist cooling system
- Powered swarf brush
- Roller track and measuring systems

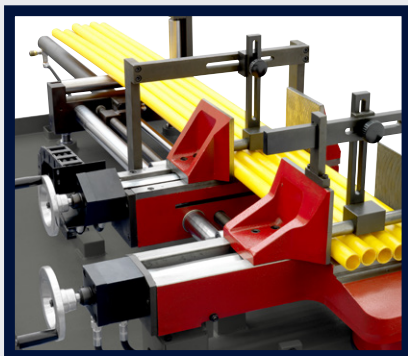

MECHANICAL BUNDLE CLAMPING DEVICE (OPTIONAL)

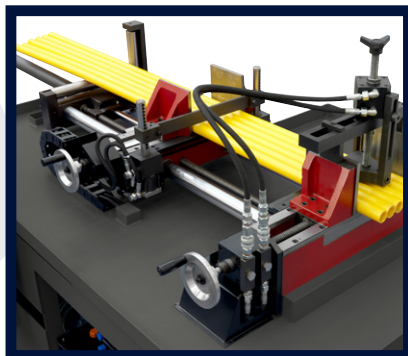

HYDRAULIC BUNDLE CLAMPING (OPTIONAL)



DRY COOLING DEVICE (OPTIONAL)



LOW CONTROL PANEL (OPTIONAL)



FREQUENCY CONVERTER (OPTIONAL WITH HIGH PANEL ONLY)



ADJUSTABLE VICE PRESSURE (OPTIONAL)



BLADE DEFLECTION CONTROL DEVICE (OPTIONAL)

TECHNICAL SPECIFICATIONS

MODEL		330SA R				370SA R				420SA R				
STOCK CODE		15128								15121				
Capacity	<input type="radio"/>	mm	250	180	110	140	280	200	130	180	300	250	150	220
	<input type="checkbox"/>	mm	240	170	110	130	260	190	130	150	270	230	140	190
	<input type="checkbox"/>	mm	270 x 200	170 x 200	110 x 170	140 x 110	310 x 240	190 x 200	130 x 180	160 x 140	310 x 270	140 x 250	140 x 150	140 x 230
Bed Height	mm	830				830				830				
Blade Size	mm	3010 x 27 x 0.9				3120 x 27 x 0.9				3270 x 27 x 0.9				
Cutting Speed	m/min	35 / 70				35 / 70				35 / 70				
Motor	Kw	0.9 - 1.5				0.9 - 1.5				0.9 - 1.5				
Length	mm	1400				1450				1500				
Width	mm	1650				1650				1700				
Height	mm	1700				1750				1800				
Weight	Kg	548				561				570				
Operation		Semi-automatic				Semi-automatic				Semi-automatic				
Vice		Hydraulic				Hydraulic				Hydraulic				